

# DUAL SOLENOID MULTIFUNCTION VALVE DRIVER

With Joystick, Potentiometer  
and Control System Interface  
P/N: DSDA-SMB Series

**Description:** The Dual Solenoid Multifunction Valve Driver provides accurate control of hydraulic proportional and directional valves used in mobile equipment and industrial processes. This multifunctional design will support inputs from a joystick potentiometer with or without center tap, a standard potentiometer or commonly available control signals such as 0 to 5 Volts, 0 to +/-5 Volts, 0 to 10 Volts, 0 to +/-10 Volts, 0 to 20 mA, 0 to +/-20 mA or 1K potentiometer. The power supply connection is conditioned to withstand the harsh environment found in vehicular power systems. Maximum current output is 2 Amps, 1 Amp, 300 mA or 100 mA. A high-low range input provides reduced output for limited operation. The driver is potted and packaged in a metal base. It holds an IP65 rating. Flat tab style or screw terminal connections are provided.

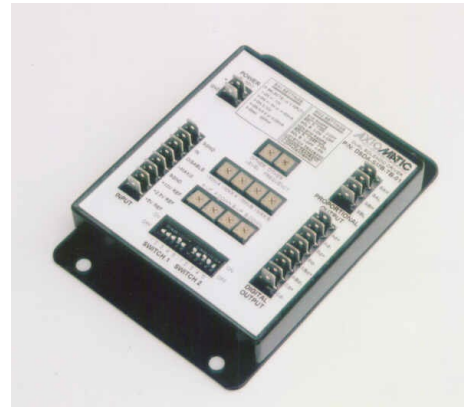

## Features:

- High efficiency PWM with superimposed dither
- High-speed power up permits the entire electronics package to be powered from safety interlock trigger switches or joystick mounted micro switches, when safety is of primary concern
- High low range input provides reduced output for limited operation (i.e. training or operation in tight spaces)
- Pump enable output active only when the joystick is active
- Suitable for harsh environments (IP65 protection rating)
- Electronic overload protection
- Static and surge protection built in
- EMI/RFI resistant
- Current sensing circuit maintains output current regardless of changes in input voltage and coil resistance
- Adjustable electronic joystick deadband jump
- Adjustable minimum current (0 to rated Amps) and maximum current (0 to rated Amps)
- Maximum current outputs include 2 A, 1 A, 300 mA, 100 mA or other values on request
- Adjustable asymmetrical ramps (0.01 to 5 Seconds) with symmetrical ramps user selectable
- Center null to accommodate joystick or potentiometer centering errors
- Master/slave option permits only one axis to operate at a time

# Application:

The Dual Solenoid Driver controls a variety of hydraulic valve combinations including:

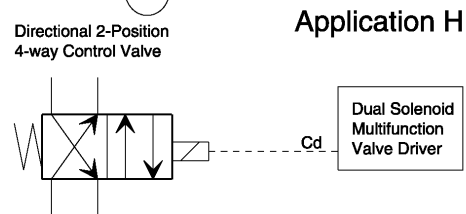
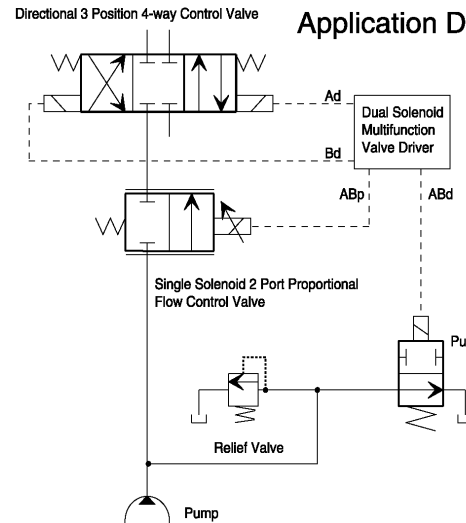
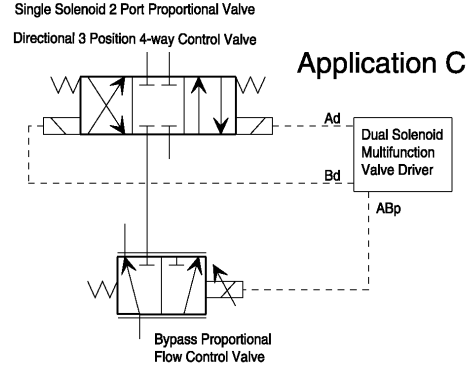
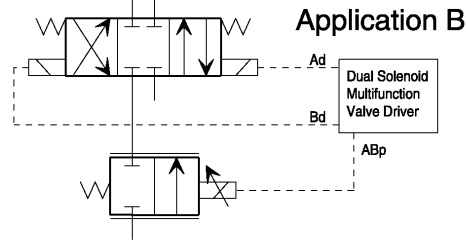
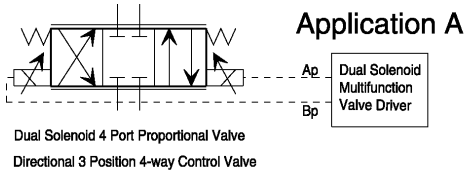

**Application E**  
Directional 2 Position 4-way Control Valve

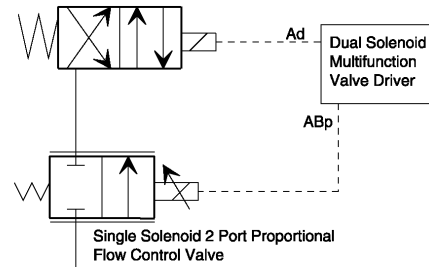

**Application F1**

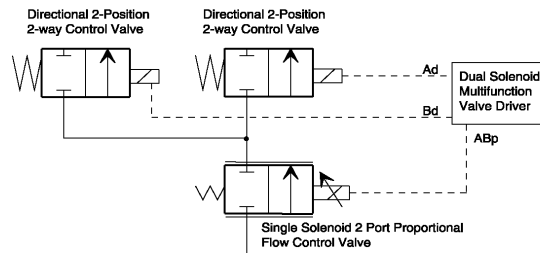

**Application F2**

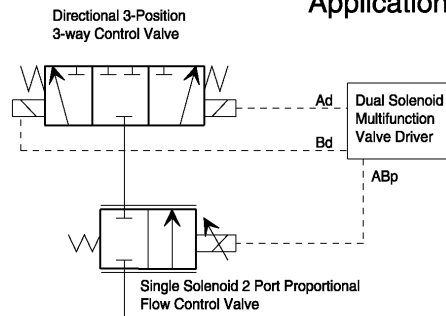

**Application G**

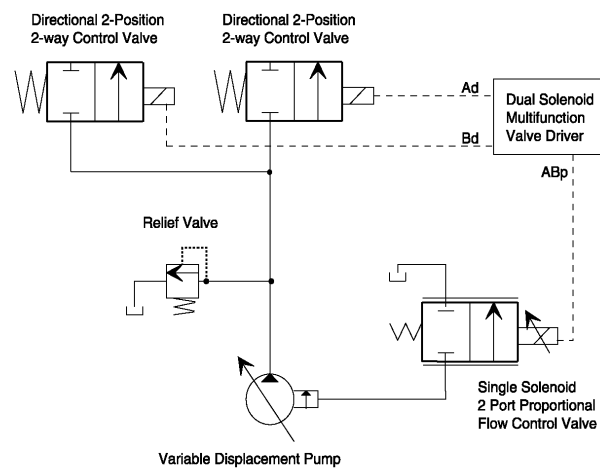

# BLOCK DIAGRAM (Dual Solenoid Driver)

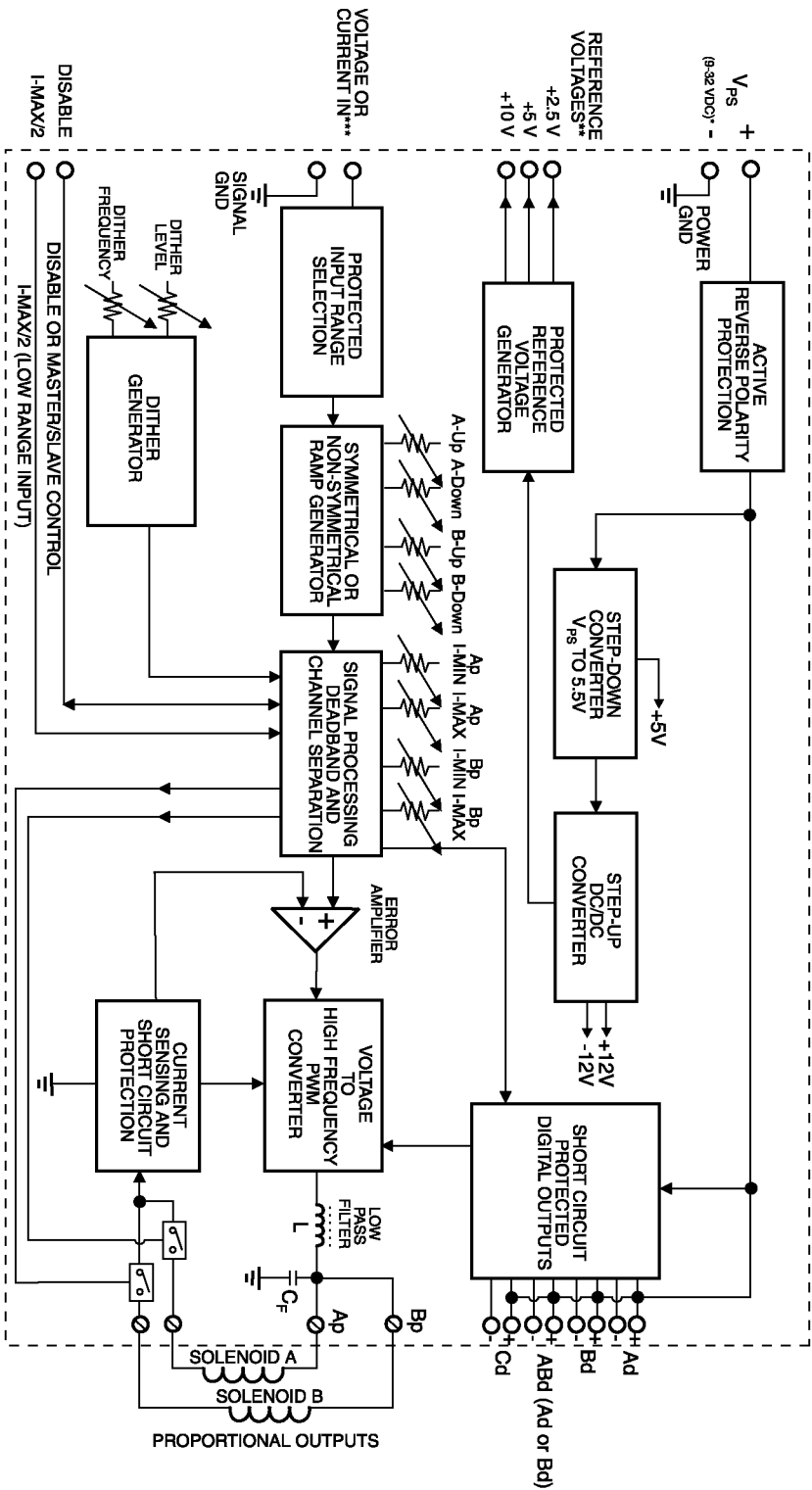

\* TOTAL CURRENT DRAWN IS THE SUM OF ALL CURRENTS DRAWN BY THE CONNECTED EQUIPMENT PLUS 25 mA.

\*\* MAXIMUM CURRENT 5 mA

\*\*\* 500K Ohm INPUT RESISTANCE IN VOLTAGE MODE, 250 Ohm INPUT RESISTANCE IN CURRENT MODE

**Dither:** Dither can be superimposed over a command signal to cause a small vibration or barely detectable oscillation of the servo valve spool. This reduces friction effects causing hysteresis and increases the linearity of the valve. The generation of acoustical noise is also significantly reduced. These are the effects that low frequency PWM is meant to cause. This design uses high frequency PWM with superimposed dither with the advantage that amplitude and frequency are user adjustable to suit the application.

**Joystick Deadband:** Deadband is the zone of the joystick or threshold of the control signal where no action is generated by joystick movement or control signal application. Deadband jump will be provided inherently by the safety microswitches if they are installed on the customer's joystick. In this case, the electronic deadband would normally be disabled. If the microswitches are not installed, the same effect can be produced with an electronic threshold. This feature can be enabled or disabled using onboard DIP switch 2. *The value of the deadband is factory set and can be specified to suit the application.*

**Joystick Center Null:** Center Null will be provided inherently by the safety microswitches on the customer's joystick, if installed. If the safety microswitches are not installed, the same effect can be provided by external connections to the input side of the solenoid driver. If the joystick potentiometer is connected to +5 V Reference, its midpoint terminal should be connected to +2.5 V Reference. This ensures that the mechanical and electrical centers of the joystick are consistent with each other.

#### CENTER TAP JOYSTICK INTERFACE

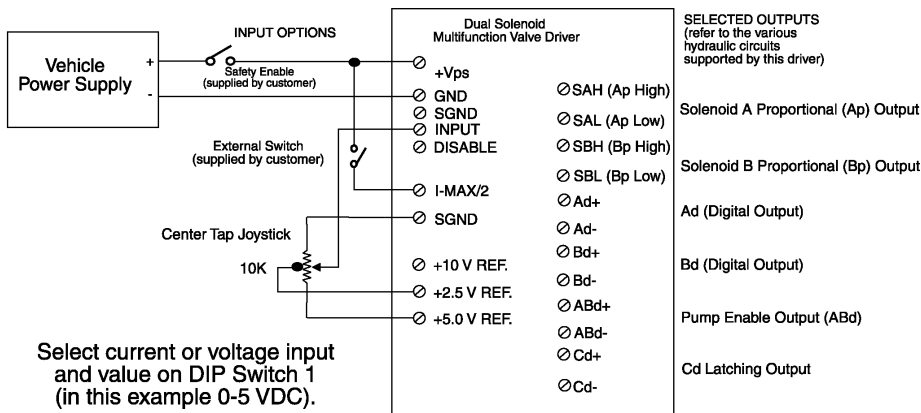

#### CONTROL SIGNAL INTERFACE

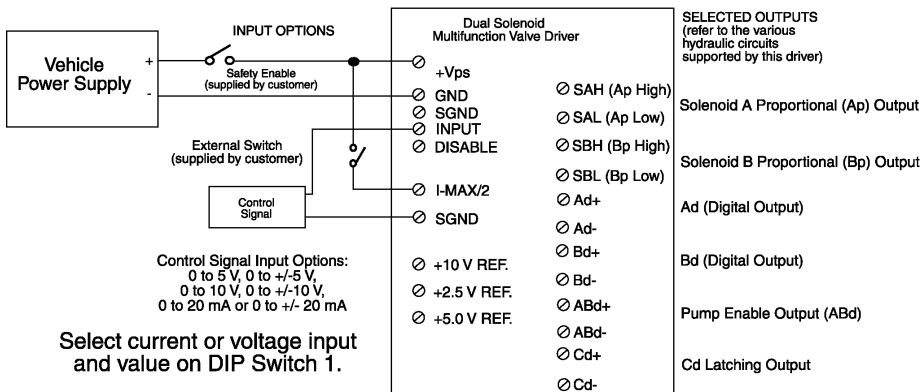

NOTE: p = proportional  
d = digital (on/off)

Multiple outputs are available to support a variety of hydraulic circuits as described on page 2. The diagram below shows the outputs from the Dual Solenoid Multifunction Valve Driver as a reflection of the movement of a remote joystick. The electronic joystick deadband (Setting 5 on Switch 2) was selected.

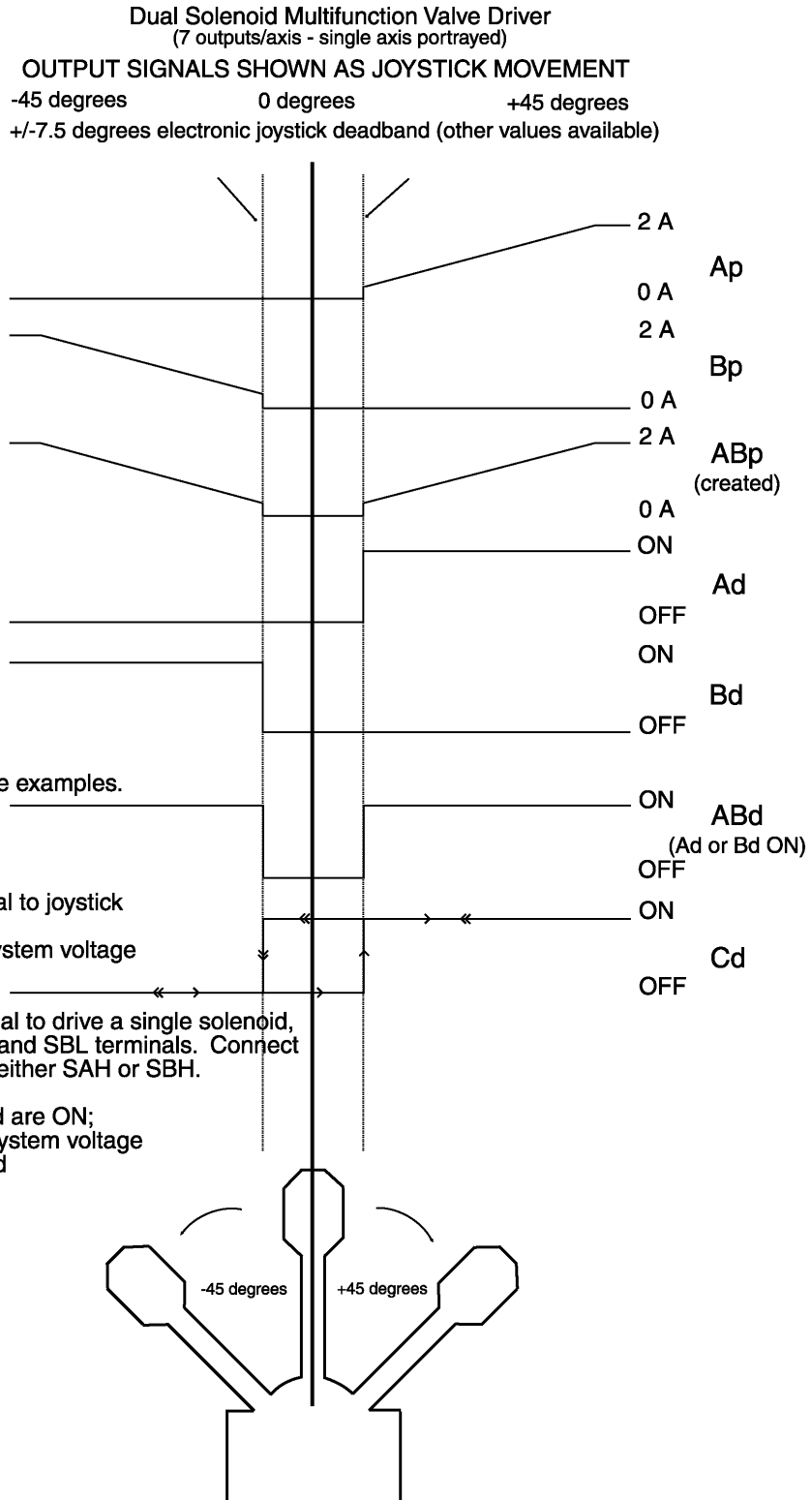

## Function:

Refer to the Connections, Input Settings and Adjustments section on page 9 for the layout of the terminals, user selectable settings and adjustments.

To create the ABp signal to drive a single solenoid, externally short the SAL and SBL terminals. Connect the solenoid to SBL and either SAH or SBH. (Note: SAH and SBH are internally connected.)

Refer to the diagram on page 5 for a definition of the output signals as a function of joystick motion.

**Maximum Output Current:** Maximum output current is limited to 2.5 Amps (min. current setting + max. current setting  $\leq 2.5$  A).

**Disable Input:** DO NOT USE THE DISABLE INPUT FOR SAFETY CONTROL. A separate external normally open switch on the input power is the best solution as illustrated on page 6.

This function disables the input command. To activate the disable input terminal, tie the disable terminal to +10V or +Vps. The controller will operate in the following manner.

1. If the output to either Solenoid A or Solenoid B is ON and the disable input is activated, the output to Solenoid A or B will remain ON. While the disable input is activated, if either Solenoid A or B is commanded OFF and then commanded ON, the output to either Solenoid will remain OFF.
2. If the output to either Solenoid A or Solenoid B is OFF and the disable input is activated, the output to Solenoid A or B will remain OFF. While the disable input is activated, if either Solenoid A or B is commanded ON, the Solenoid will remain OFF. If then, the disable input is removed, the output to the Solenoid will turn ON.

**Master/Slave:** In a multi-axis system it is sometimes desirable to prevent more than one axis from operating at a time. By connecting the master/slave links together in parallel, using the Disable terminal, operation will be limited to the first axis to be engaged. In other words, the upstream joystick will have priority.

**Multiple-axis:** The Dual Solenoid Driver is designed to accept the output from a single axis of a joystick. For multi-axis applications, where more than one axis operates at a time, use one Dual Solenoid Driver per axis.

**Cd output:** The Cd output is useful for forward/reverse or up/down applications. If the joystick is pushed forward past its deadband, the unit will remain in forward mode unless the joystick is pulled into reverse past the joystick's deadband of  $-7.5$  degrees.

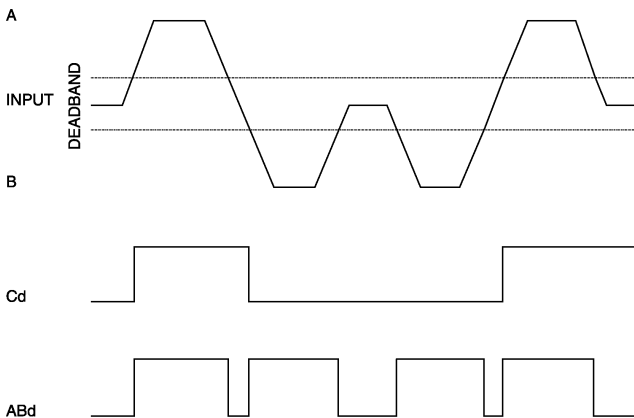

The Cd signal output turns on when the input signal reaches the  $+7.5$  degree deadband setpoint. It remains on until the input signal reaches the  $-7.5$  degree deadband setpoint (opposite direction).

Returning the input signal to the  $+7.5$  degree deadband setpoint after the Cd output goes off, restarts the cycle.

An ABd (pump enable) output signal is shown as a comparison.

## Technical Specifications:

Specifications are indicative and subject to change. Actual performance will vary depending on the application and operating conditions. Users should satisfy themselves that the product is suitable for use in the intended application. All our products carry a limited warranty against defects in material and workmanship. Please refer to our Warranty, Application Approvals/Limitations and Return Materials Process as described on <https://www.axiomatic.com/service/>.

All specifications typical at nominal input voltage and 25°C unless otherwise specified.

## General Specifications

Operating conditions	-40 to +85 degrees C (-40 to 185°F)
Storage temperature	-50 to +125 degrees C (-58 to 257°F)
Protection	Potted (encapsulated) IP65 rating
Weight	1.45 lbs. (0.66 kg) (DSDA-SMB-TB-01)
Electrical connection	DSDA-SMB-TB-01: 22 flat tabs Mates with 0.25 inch female tab connector, supplied by customer (Keystone P/N: 4470) and accepts 16-20 AWG wire DSDA-SMB-SC-01, DSDA-SMB-SC-MT-1A: 22 pluggable polyamide screw terminals Mating female vertical plug connectors provided that accepts 16-20 AWG wire
Dimensions	Potted unit packaged in a metal base 3.87 x 5.37 x 1.17 inches or 98.4 x 136.5 x 29.74 mm (W x L x H) (Contact manufacturer for application-specific requirements.)

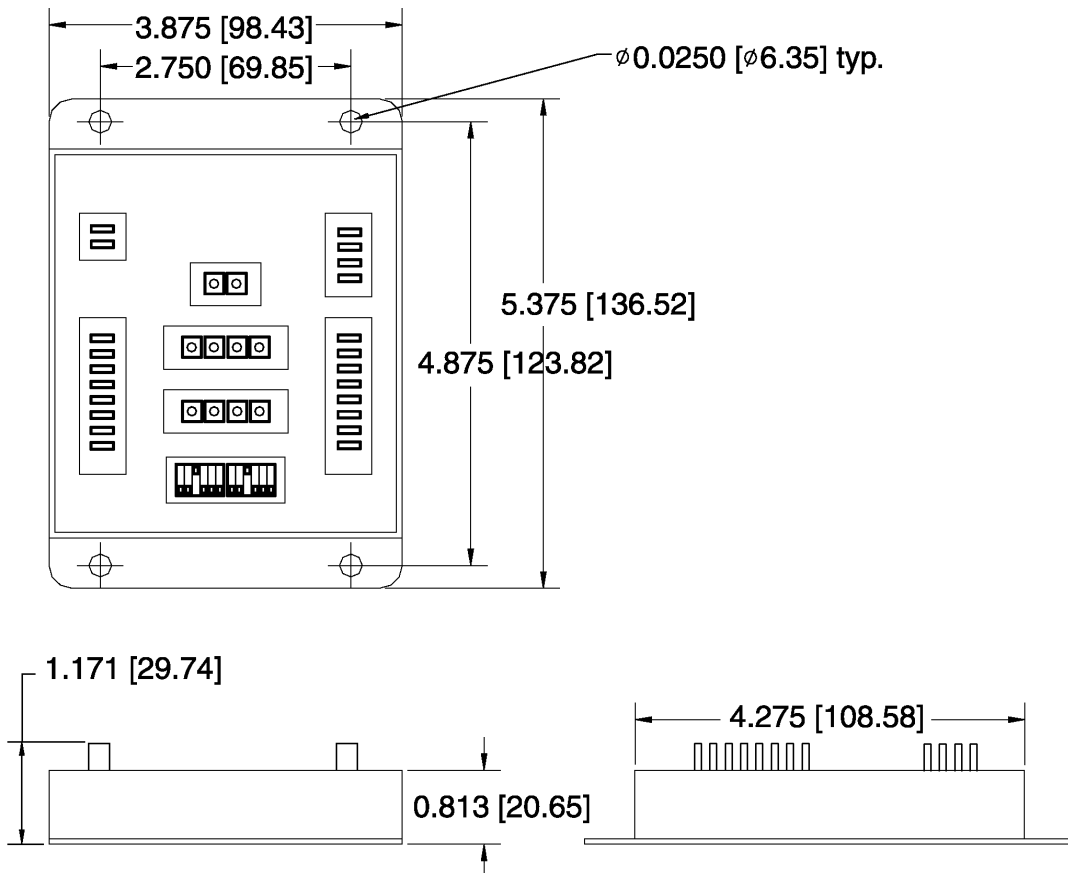

Dimensions: inches [mm]

## Input Specifications

For proper operation, match the power supply voltage with rating of coil. Operating the driver with a supply voltage lower than the valve's rated voltage may result in reduced maximum current output.

Operating voltage (power supply requirement)	9 to 32 VDC power supply range (24 VDC nominal) Reverse polarity protection <i>Total current draw will be the sum of the currents drawn by all connected equipment plus 25 mA.</i>
Control input signal options - voltage	0 to 5 Volts (2.5 V = 0, +/-2.5 V), 0 to 10 Volts (5 V = 0, +/-5 V), 0 to +/-5 Volts (0 V = 0, +/-5 V), or 0 to +/-10 Volts (0 V = 0, +/-10 V) (user selectable by DIP Switch 1) <i>Other signal inputs are available (contact manufacturer).</i>
Control input signal options - current	0 to 20 mA (10 mA = 0, +/-10 mA), or 0 to +/-20 mA (0 mA = 0, +/-20 mA) (user selectable by DIP Switch 1) <i>Other signal inputs are available (contact manufacturer).</i>
Joystick potentiometer input	The potentiometer connection provides a 5.0 VDC bias voltage as well as a 2.5 VDC center-tap driving voltage. A remote joystick potentiometer with or without center tap may be used. A 10K potentiometer is recommended. The unit accepts potentiometers from 2.5K-50K Ohms as well as a 1K potentiometer (only in Models: DSDA-SMB-1K-TB and DSDA-SMB-1K-SC).
Low range input (I <sub>max</sub> /2)	This input, when active, will provide a 50% reduction in output current slope. It is used to increase the resolution of operation for limited operation such as when training new operators or during operation in tight quarters. It is activated by applying power (+9-32VDC) to the I <sub>max</sub> /2 tab and if not used, it may be left unconnected.
Input resistance	Voltage mode: 500K Ohms    Current mode: 250 Ohms

## Output Specifications

All outputs can operate a solenoid or relay rated to correspond with the maximum current output rating of the controller. Each output can withstand an indefinite short circuit to power or ground. Each output is protected from over-voltage with a re-circulating diode. The solenoid coils and on/off valves should have no polarity or protection diodes for proper operation of the device. The maximum current output of the driver should not exceed the current rating of the solenoid coil.

Range of maximum output current	DSDA-SMB-TB-01, DSDA-SMB-SC-01: 2000 mA DSDA-SMB-SC-MT-1A: 1000 mA <i>For 2 Amp versions, maximum output current is limited to 2.5 A (min. current setting + max. current setting ≤ 2.5 A).</i>
Solenoid resistance selection (nominal)	Nominal resistance of solenoid coil should comply with: $R_{coil} \leq (V_{power\ supply} - 1.5\ V) / I_{max}$
Minimum current setting (Sol A and B)	0 to rated Amps (adjustable)
Maximum current setting (Solenoid A and B)	0 to rated Amps (adjustable) The maximum current is offset by the minimum current setting.
Current ramp time - up and down (Solenoid A and B)	0.01 - 5 seconds (symmetrical or non-symmetrical*) (*select with DIP Switch 2)
Dither amplitude Dither waveform Current dither frequency	0 to 10% of maximum current (adjustable) Triangular 70 to 350 Hz ±10% of full scale (adjustable)



# Connections, Input Settings and Adjustments

The Metal Box will accommodate up to ¼ inch mounting screws (not supplied). Maximum current output rating shown below is 2 Amps. Refer to unit part number for other available output ratings.

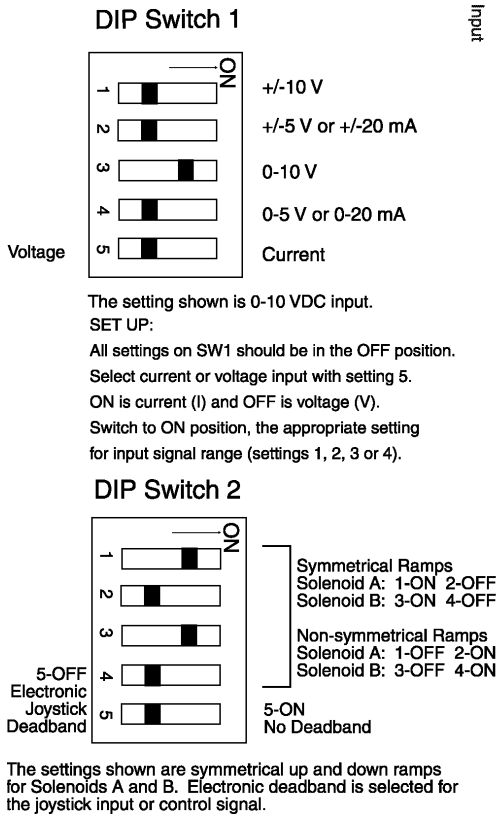
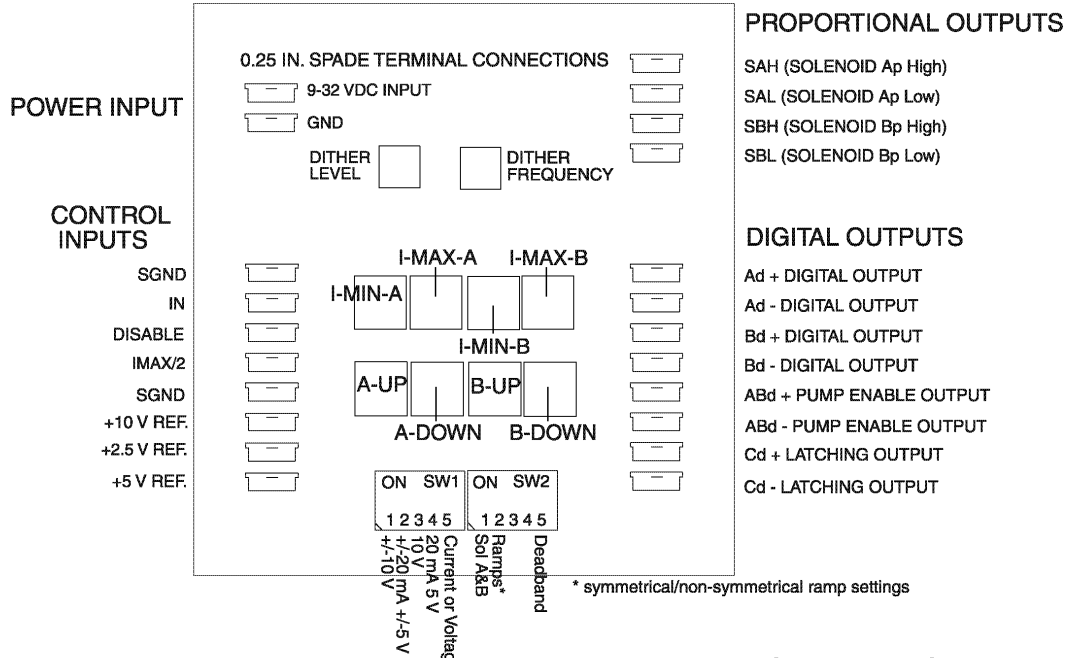

## ADJUSTMENTS

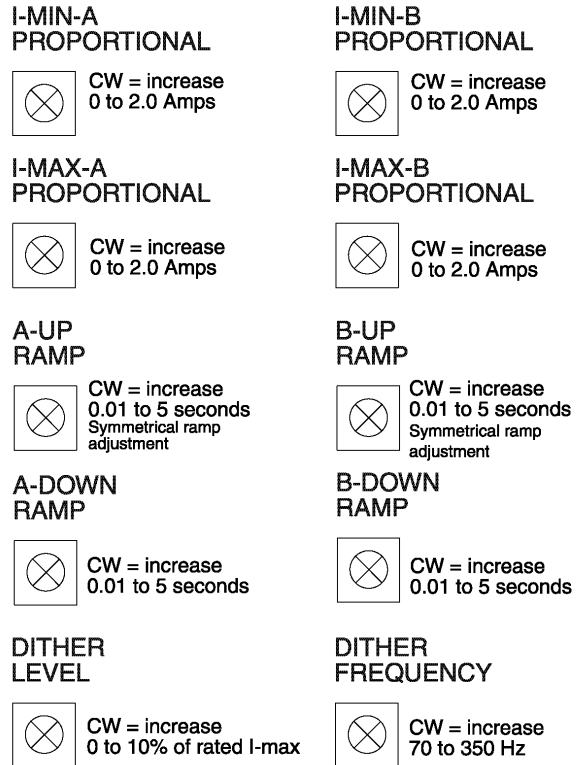

Adjustments to the single turn potentiometers are made using a flat head or Philips screwdriver.  
 For P/N: DSDA-SMB-SC-MT-1A, minimum and maximum current adjustments are 20 turn pots.

Settings/Adjustments	Range of Adjustment
Input signals	Select the appropriate current or voltage signal (DIP switch 1).
Minimum Current Setting ( $I_{min}$ ) for Solenoid A	0 to 2000 mA* (CW = increase)
Maximum Current Setting ( $I_{max}$ ) for Solenoid A	0 to 2000 mA* (CW = increase)
Minimum Current Setting ( $I_{min}$ ) for Solenoid B	0 to 2000 mA* (CW = increase)
Maximum Current Setting ( $I_{max}$ ) for Solenoid B	0 to 2000 mA* (CW = increase)
I-max/2	Full speed (unconnected) Half-speed (activated by applying 9-32 VDC through an external switch supplied by customer)
Symmetrical/non-symmetrical ramps	Symmetrical/non-symmetrical (user selected by DIP switch 2)
Rising Ramp Time for Solenoid A	0.01 to 5 seconds (CW = increase; CCW = decrease)**
Falling Ramp Time for Solenoid A	0.01 to 5 seconds (CW = increase; CCW = decrease)
Rising Ramp Time for Solenoid B	0.01 to 5 seconds (CW = increase; CCW = decrease)**
Falling Ramp Time for Solenoid B	0.01 to 5 seconds (CW = increase; CCW = decrease)
Dither Amplitude	0 to 10% of rated maximum current (CW = increase; CCW = decrease)
Dither Frequency	70 to 350 Hz ( $\pm 10\%$ ) (CW = increase; CCW = decrease) Dither waveform is triangular.
Deadband Jump	+/- 7.5 degrees (user selected by DIP Switch 2) <i>Contact the manufacturer for custom deadband jump settings.</i>

\* Maximum output current range is limited to 2.5 A (min. current setting + max. current setting  $\leq$  2.5 A).

\*\* If symmetrical ramps are selected, the rising ramp trim pot for each solenoid should be used to set the ramp time and the falling ramp trim pot of each solenoid is disabled.

CW = clockwise, CCW = counterclockwise

### Ordering Part Number: PACKAGED – POTTED IN METAL BASE

2A output, with tabs: DSDA-SMB-TB-01

2A output, with screw terminals: DSDA-SMB-SC-01

1A output, with screw terminals, 20 turn trimpots for min.

and max. current adjustments: DSDA-SMB-SC-MT-1A

Specify electronic joystick deadband if other than +/-7.5 degrees.

Form: TD1000AX-06/15/23