

SOFT SHIFT CONTROLLER – COIL MOUNT



Soft shift controller connected to a proportional solenoid valve introduces a current

Ordering Part Number: SSD-H-t-02-x-yM

Where:

- t = 1 - 0.01 to 5 seconds ramp on time
- t = 2 - 5 to 10 seconds ramp on time
- t = x - customer specified ramp on time
- x = 2A or 650mA (maximum current output)
- y = length in meters of cable (2 meters is standard)

Function:

The Soft Shift Controller introduces a current ramp permitting the soft start of proportional solenoid valves used for pressure or flow control in hydraulic circuits.

When the unit is powered on, it ramps to full current output over the ramp on time period that is adjustable within a factory set range. When the power is switched off, output of the unit falls immediately to zero.

Features:

- Cost effective alternative for soft start of proportional hydraulic circuits
- Broad range of supply voltages (9 to 32 VDC)
- Modern technology utilizing high frequency switching output (PWM)
- Current sensing circuit maintains output regardless of changes in input voltage and coil resistance
- Maximum current output is adjustable (2A or 650 mA available)
- Ramp on time (adjustable)
- Dither frequency fixed at 250 Hz
- Rugged construction for harsh environments
- IP65 protection class

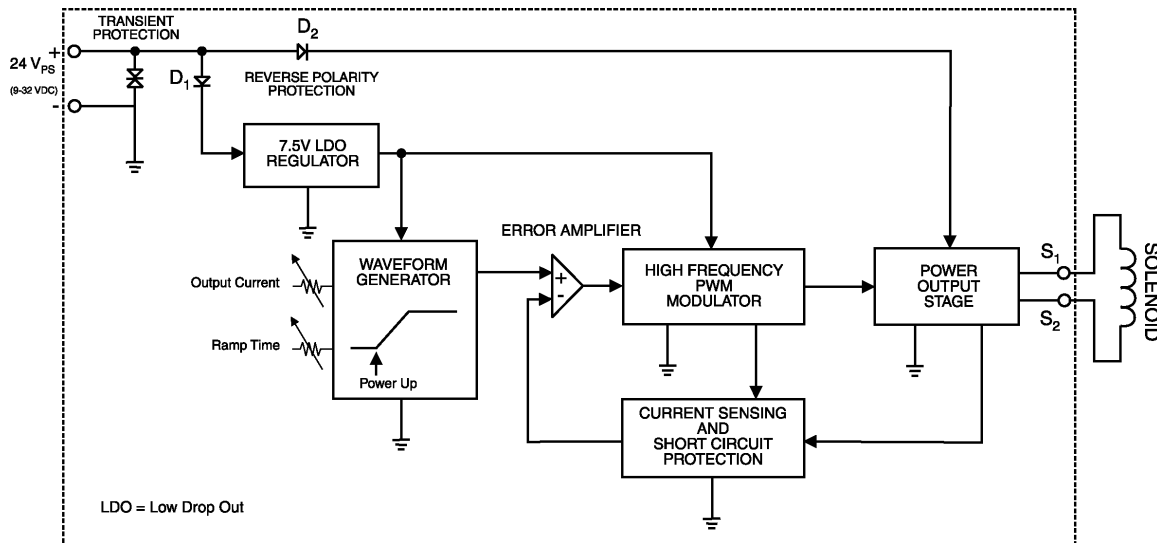

Technical Specifications:

Specifications are indicative and subject to change. Actual performance will vary depending on the application and operating conditions. Users should satisfy themselves that the product is suitable for use in the intended application. All our products carry a limited warranty against defects in material and workmanship. Please refer to our Warranty, Application Approvals/Limitations and Return Materials Process as described on <https://www.axiomatic.com/service/>.

All specifications are typical at nominal input voltage and 25 degrees C unless otherwise specified.

General Specifications

Quiescent Current	5.9 mA @ 12VDC 6.9 mA @ 24VDC 7.3 mA @ 32VDC
Operating conditions	-40 to +85°C (-40 to 185°F)
Electrical connection	DIN 43650 plug connects to solenoid coil Unterminated jacketed cable connects to power supply Red (power +) and black (power -), 18 AWG conductors 2 meter cable length (other lengths are available)
Weight	0.30 lbs. (0.14 kg)
Protection class	IP65 when correctly installed with lid, compression washer, o-ring and base gasket

Dimensions in mm/inches (excluding cable)

Length L1	85.35mm	3.36"
L2	61.75mm	2.43"
L3	34.00mm	1.34"
Width = L3	34.00mm	1.34"
Height H1	38.00mm	1.49"

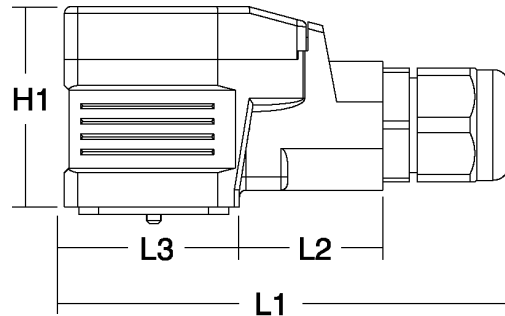

Electrical Specifications

Operating voltage	9 to 32 VDC power supply range
Output current range (adjustable)	900 to 2000 mA (2A version) 200 to 650 mA (650 mA version)
Solenoid resistance selection (nominal)	Nominal resistance of solenoid coil should comply with: $I_{output} = (V_{power\ supply} - 1.5) / R_{coil}$ Where $I_{output} \leq 2A$
Ramp on time (adjustable)	0.01 to 5 seconds or 5 to 10 seconds or customer specified range
Dither Frequency	250 Hz +/- 10% (fixed)
Dither Amplitude	10% of maximum (fixed)

Note 1: For proper operation, match the power supply voltage with rating of solenoid coil. Operating the driver with a supply voltage lower than the solenoid rated voltage may result in reduced current output.

Note 2: It is not necessary for the coil to have polarity or protection diodes.

Note 3: The current output of the driver should not exceed the current rating of the solenoid coil.

Adjustments:

To access the trim pots, remove the screw and lift off the transparent cover.

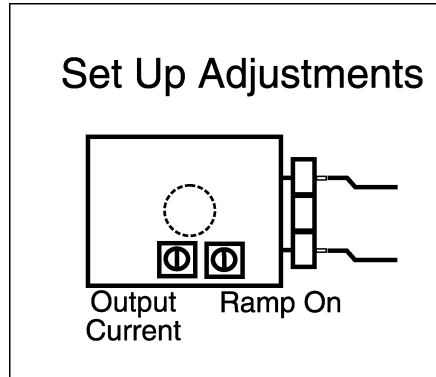
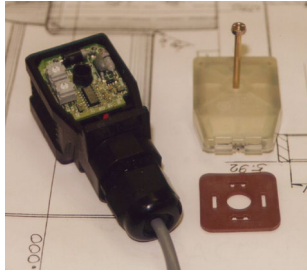

Trim Pot Adjustments <i>(use a Phillips #0 screwdriver)</i>	Range of Adjustment	Factory Setting <i>(upon request of customer)</i>
Output Current <i>Single turn trim pot</i>	0.9 to 2.0A (2A version) 200 to 650mA (650mA version)	Minimum (CCW)
Ramp On Time <i>Single turn trim pot</i>	0.01 to 5 seconds or 5 to 10 seconds or customer specified range	Maximum (CW)

Mounting the unit:

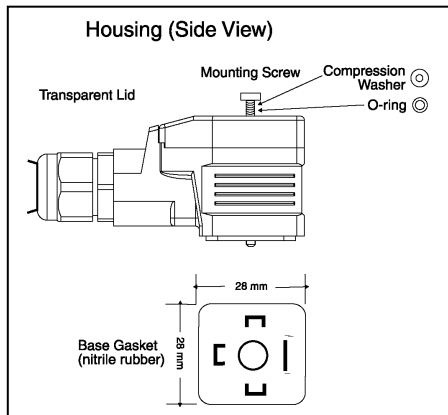

1. Ensure the lid, compression washer, o-ring and base gasket are correctly in place (necessary for IP65 protection).
2. Ensure that no damage or injury can occur on the machine when the valve is operated.
3. Attach the soft shift controller to the solenoid coil and tighten the mounting screw using a Phillips #2 screwdriver.
4. Connect the cable to the power supply.
5. Switch on the power supply to the soft shift controller.
6. Adjust the current output and ramp on time to suit the application.

Form: TD1900AX-06/15/23