

**RTD Scanner, Eight Channel
with CAN, SAE J1939**

USER MANUAL

**P/N: AXRTD8,
AXRTD8-03**

VERSION HISTORY

Version	Date	Author	Modifications
1.0.0	June 27, 2008	Anna Murray	Initial Draft
1.0.1	October 6, 2008	Anna Murray	Removed a reference to Cold Junction in Section 1.1 which was a holdover from the AXTC20 user manual.
1.0.1a	October 28, 2008	A. Wilkins	Power supply range 8...60VDC
1.0.2	March 10, 2009	Manraj S. Pannu	Dimensional drawing updated. Registered trademark (®) added to Electronic Assistant.
2.0.0	August 27, 2009	Anna Murray	Updated SPN List per J1939-71, JAN 2009 Added "User Defined" capability for SPNs
2.0.1	November 22, 2010	Amanda Wilkins	Added Technical Specifications
3.0.0	December 19, 2011	Amanda Wilkins	New Revision H/W – Updated User Manual, no change in functionality
3.1.0	April 26, 2012	Anna Murray	Added Section 5 "Using RS-232 with Tera Term"
3.1.1	October 9, 2012	Amanda Wilkins	Added input resistance range and clarified isolation.
-	November 19, 2012	Amanda Wilkins	Added marine type approvals and vibration information
3.1.1A	January 9, 2014	Olek Bogush	Added "Short Circuit" and "Open Circuit" conditions to the Technical Specification
3.1.1A	October 2, 2015	Amanda Wilkins	Updated IP rating to IP67 based on test results
3.1.2A	May 11, 2017	Ilona Korpelainen	Updated to reflect V5.1.4. firmware: Added setpoints for Short Circuit and Open Circuit diagnostics.
3.1.3A	May 24, 2017	Ilona Korpelainen	Added note of AXRTD8-03

ACCRONYMS

ACK	Positive Acknowledgement
DM	Diagnostic Message (from SAE J1939 standard)
DTC	Diagnostic Trouble Code
EA	Axiomatic Electronic Assistant® (Service Tool for Axiomatic ECUs)
ECU	Electronic Control Unit (from SAE J1939 standard)
NAK	Negative Acknowledgement
PDU1	A format for messages that are to be sent to a destination address, either specific or global
PDU2	A format used to send information that has been labeled using the Group Extension technique, and does not contain a destination address.
PGN	Parameter Group Number (from SAE J1939 standard)
RTD	Resistance Temperature Detector
SPN	Suspect Parameter Number (from SAE J1939 standard)

TABLE OF CONTENTS

1. GENERAL	4
1.1. Description of RTD Scanner	4
1.2. Introduction to SAE J1939 Features	6
1.3. Sending Single Frame Messages	7
1.4. Dimensions and Pinout	8
1.5. Installation Instructions	10
2. DIAGNOSTIC MESSAGES	13
2.1. Supported FMIs	13
2.2. Diagnostic Log	14
2.3. Clearing Active DTCs	14
3. ECU SETPOINTS	15
3.1. RTD Setpoints	15
3.2. Miscellaneous Setpoints	21
4. USING ECU WITH AXIOMATIC ELECTRONIC ASSISTANT®	23
4.1. Installing the Electronic Assistant®	23
4.2. Screen Captures	23
5. USING RS-232 WITH TERA TERM	26
5.1. M – Main Menu Options	27
5.2. V – View Parameters	27
5.3. C – Change Parameters	29
5.4. D – Default Parameters	29
5.5. S – Show/Stop Diagnostics	30
5.6. L – Load New Software	31
Appendix A - Technical Specifications	A

References

J1939	Recommended Practice for a Serial Control and Communications Vehicle Network, SAE, October 2007
J1939/21	Data Link Layer, SAE, December 2006
J1939/71	Vehicle Application Layer, SAE, January 2009
J1939/73	Application Layer-Diagnostics, SAE, September 2006
J1939/81	Network Management, SAE, May 2003
TDAXRTD8	Technical Datasheet, RTD Module, 8 Channel, Axiomatic Technologies
UMAX07050X	User Manual, Electronic Assistant® and USB-CAN, Axiomatic Technologies, 2006-2009

1. GENERAL

This user manual describes both AXRTD8 and AXRTD8-03 products. In AXRTD8-03 a small offset is added to the measured temperature to compensate inaccuracy in lead wire resistance measurement.

1.1. Description of RTD Scanner

There are eight channels on the AXRTD8, each with four pins at the connector for 2, 3 or 4 wire connections, as well as a fifth pin for a shield. The RTD scanner will source current on pin A for all types of RTD sensors.

In the case of a 2-wire device, it will read the voltage between Pin A and GND, with no compensation for any resistance added by the wires. For 3-wire devices, it reads the voltage at Pin A, as well as that at Pin C. The Pin C reading will allow the device to calculate the approximate resistance in one wire, and will subtract twice that value from the calculated resistance based on the voltage measure at A. Lastly, for 4-wire devices, it will read the voltage at Pin B which already takes into account the resistance of the wire from A. It will also measure the voltage at Pin C to calculate the return wire resistance, and subtract that from the measured value at B.

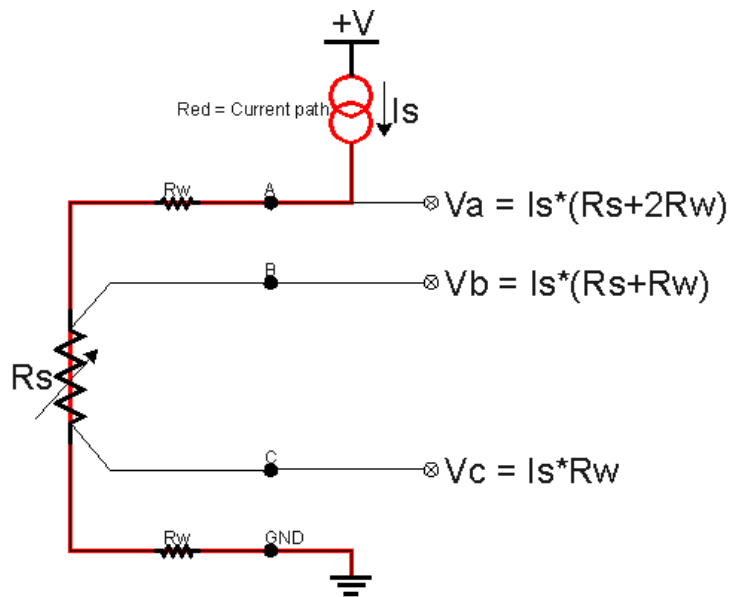

$$\text{2-Wire: } R_s = V_a / I_s - 2R_w$$

$$\begin{aligned} \text{3-Wire: } V_a - 2V_c &= I_s R_s + 2I_s R_w - 2I_s R_w \\ R_s &= (V_a - 2V_c) / I_s \end{aligned}$$

$$\begin{aligned} \text{4-Wire: } V_b - V_c &= I_s R_s + I_s R_w - I_s R_w \\ R_s &= (V_b - V_c) / I_s \end{aligned}$$

In the case of a 4 wire RTD, if the wire to A is broken, the unit will report the load a short circuited because there will be no voltage on Pin B.

All channels are fully isolated from the CAN lines, and from the power supply. The power supply was designed for nominal inputs of 12Vdc or 24Vdc and will provide proper operation from 9 to 32Vdc.

Active channels are scanned sequentially (1 to 8) with approximately 100ms between readings. For 2-wire types, there is one reading per channel, whereas 3 or 4 wire types require two readings per channel. On every read-thru of the channels, there is also a measurement taken of the common current source used to generate the voltage on each channel.

For 3 or 4 wire type channels, the wire resistance is only checked after 600 reads from the AtoD, since it does not change that frequently. This means the wire resistance is read and update once a minute.

If all 8 channels are active, it takes approximately 900ms to read through all the channels, and the current source. Therefore, any individual channel's reading is updated at least once per second, less if not all channels are active.

If desired, the average temperature of all the active channels can be broadcasted to the network using the default "Engine Average Information" PGN, or on a Proprietary B message. This feature is described in detail in section [3.2](#).

On power-up, the AXRTD8 will immediately send its NAME to the network. However, in order to prevent erroneous readings before all the data from all 8 channels + current source have been read correctly, the unit will only start broadcasting either temperature or diagnostic data after 10 seconds have elapsed.

To measure voltages, the AXRTD8 uses a very precise (24bit) dual channel analog-to-digital converter with a programmable gain. The differential RTD inputs are multiplexed to the ADC chip. It has a programmable filtering for either 50Hz or 60Hz. The ADC provides a minimum 100dB normal mode rejection of the line frequency and its harmonics.

Temperature is measured in °C, with a 0.001°C resolution. When installed properly, as described in section [1.5](#), the scanner will send temperatures with +/- 1°C accuracy typical at ambient temperature.

1.2. Introduction to SAE J1939 Features

The software was designed to provide flexibility to the user with respect to messages sent from the AXRTD8 by providing:

- Configurable ECU Instance in the NAME (to allow multiple ECUs on the same network)
- Easily selectable SPN from a drop list of the temperature SPNs supported by the standard.
- Configurable Diagnostic Messaging Parameters
- Diagnostic Log, maintained in non-volatile memory

This document assumes the reader is familiar with the SAE J1939 standard. Terminology from the standard is used, but is not described in this document.

The ECU is compliant with the standard SAE J1939, and supports the following PGNs from the standard.

From J1939-21 - Data Link Layer

- Request 59904 (\$00EA00)
- Acknowledgment 59392 (\$00E800)
- Transport Protocol – Connection Management 60416 (\$00EC00)
- Transport Protocol – Data Transfer Message 60160 (\$00EB00)
- Proprietary B, available messages 65281 (\$00FF01)
to 65535 (\$00FFFF)

From J1939-73 - Diagnostics

- DM1 – Active Diagnostic Trouble Codes 65226 (\$00FECA)
- DM2 – Previously Active Diagnostic Trouble Codes 65227 (\$00FECB)
- DM3 – Diagnostic Data Clear/Reset for Previously Active DTCs 65228 (\$00FECC)
- DM11 – Diagnostic Data Clear/Reset for Active DTCs 65235 (\$00FED3)
- DM14 – Memory Access Request 55552 (\$00D900)
- DM15 – Memory Access Response 55296 (\$00D800)
- DM16 – Binary Data Transfer 55040 (\$00D700)

From J1939-81 - Network Management

- Address Claimed/Cannot Claim 60928 (\$00EE00)
- Commanded Address 65240 (\$00FED8)

From J1939-71 – Vehicle Application Layer

- All of the temperature SPNs from this section, and their corresponding PGNs. See section 3.1 for more information.

1.3. Sending Single Frame Messages

Each SPN that is supported by the AXRTD8 has a predefined size (1 or 2 bytes) and consequently resolution and offset, associated with it.

One-byte parameters have a resolution of 1°C/bit and an offset of -40°C, resulting in a measurable range of -40°C to 210°C. Temperatures outside of that range are sent as either the minimum or maximum value allowable. If an open-circuit is detected on that channel, the data will be sent as 254 (0xFE), the error indicator value.

Two-byte parameters have a resolution of 0.03125°C/bit and an offset of -273°C, resulting in a measurable range of -273°C to 1735°C. Temperatures outside of that range are sent as either the minimum or maximum value allowable. If an open-circuit is detected on that channel, the data will be sent as 65279 (0xFEFF), an error indicator value.

The SPN drop list includes all temperature SPNs from the J1939-71 standard published up to January of 2009. If an SPN is not supported by the drop list, the user can select a zero SPN, which then allows them to define the SPN and PGN per the application requirements.

In addition to being able to detect open circuits, the AXRTD8 keeps a log of the last 10 scans of raw data measured from the ADC chip for the “high” (Pin A or B) voltage. If the raw data has not changed after 10 scans, the scanner will stop broadcasting the ‘frozen’ data, and start sending the error indicator (0xFE) instead. No DTC is associated with this condition, so the DM1 message will not be changed should this happen on one or more channels. This is a redundant safety feature, and should never occur.

The Parameter Group Number (PGN) that will be used to send a temperature to the J1939 network will be entirely dependant on the Suspect Parameter Number (SPN) that was selected for that channel. In all cases, the PGN is a PDU2 type. Each PGN has a predefined priority and repetition rate associate with it.

Regardless of the SPN selected, the temperature is always available on request for the associated PGN.

All single-frame messages sent from the RTD8 will be sent as 8-bytes. Unused bytes within the PGN are stuffed with 0xFF as per the standard.

If more than one channel is selected to use the same SPN, the HIGHEST temperature will always be sent. If one channel has an open-circuit, and the other(s) a valid temperature, the PGN will be sent with the temperature data AND a DM1 message will be sent indicating an open-circuit for that SPN. The error indicator data in the temperature message will only be sent if BOTH channels are showing an open-circuit at the same time. For this reason, setting up multiple channels for the same SPN should be used with caution.

1.4. Dimensions and Pinout

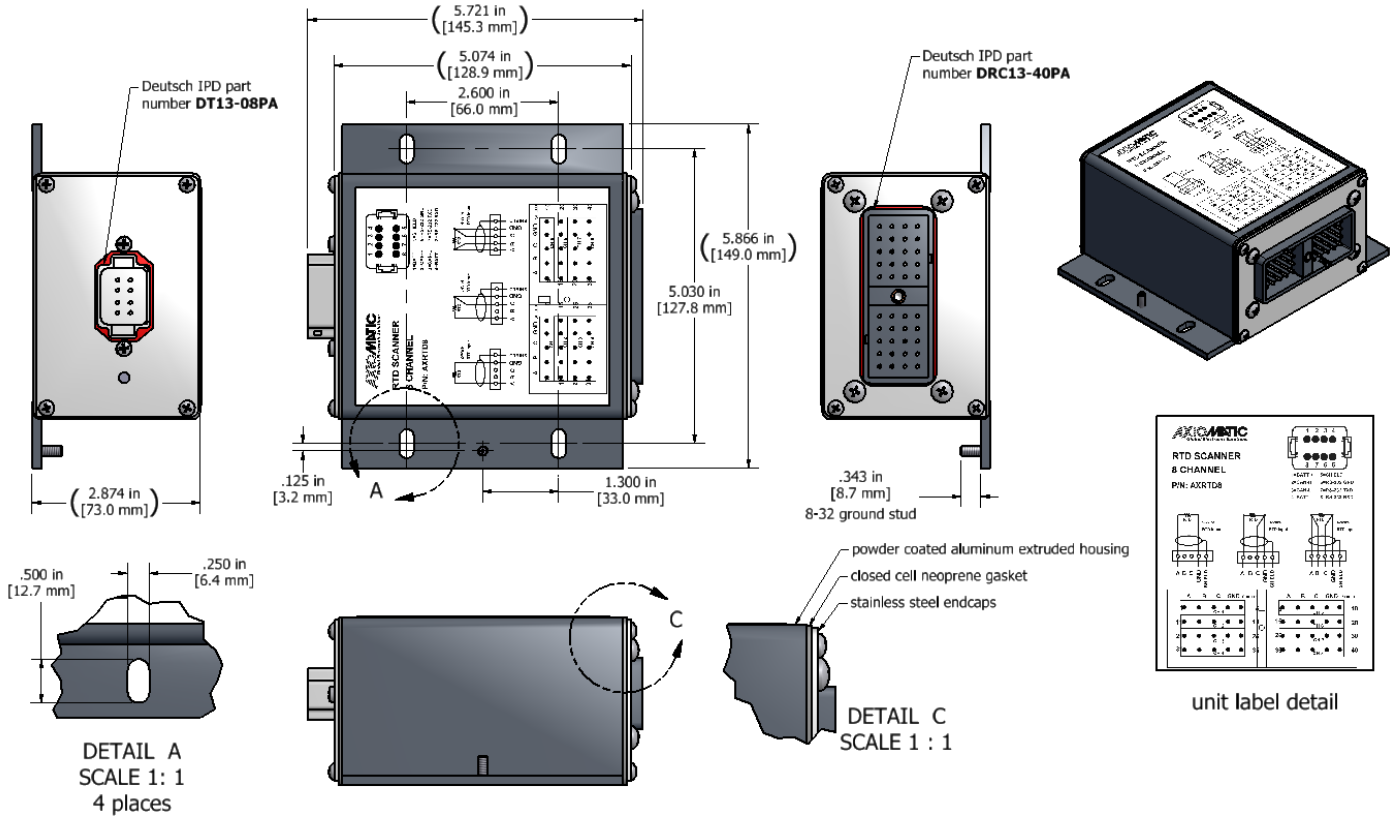

Typical Connections – Power and CAN:

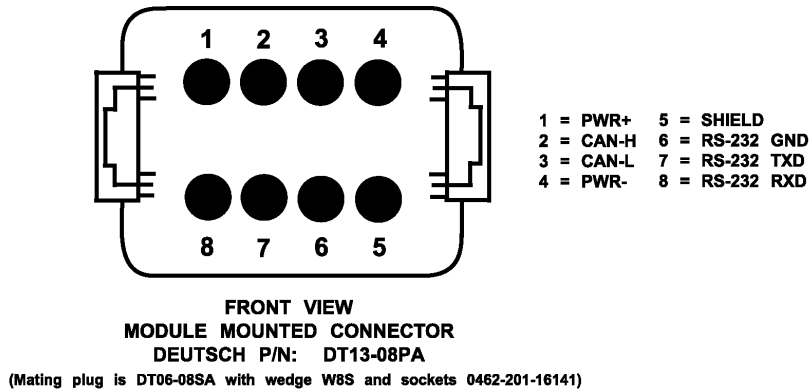

Typical Connections – I/O:

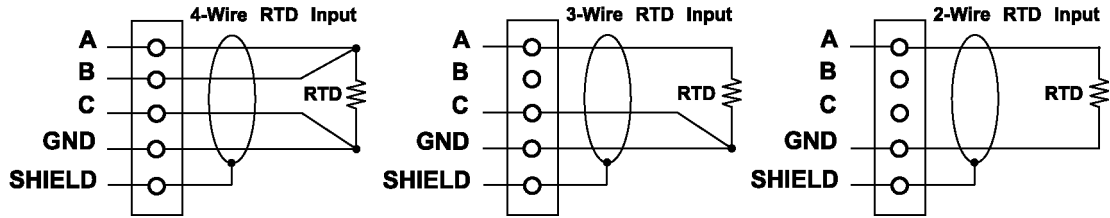

RTD MODULE - PIN OUT

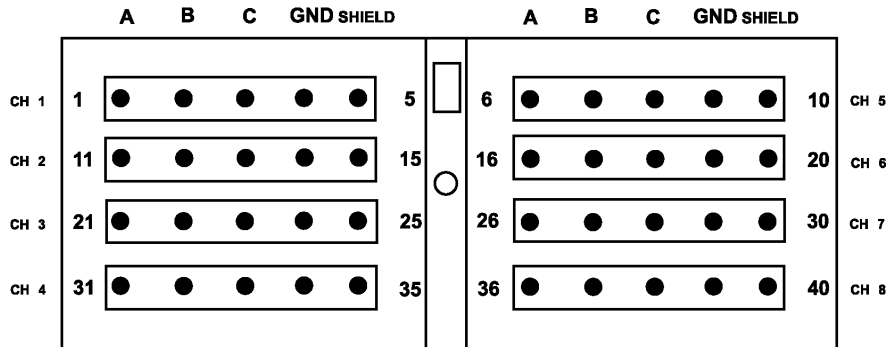

FRONT VIEW OF
MODULE MOUNTED CONNECTOR

Nov. 3/03 AJW

The mating plug is Deutsch IPD p/n DRC16-40SA with sockets 0462-201-16141.

Axiomatic offers a mating plug kit for the product, P/N: **AX070200**.

This kit includes the following items.

NB. The sealing plugs are only needed in cases where not all of the 40 pins are used.

Deutsch IPD P/N:	Description:
0462-201-16141	48 16AWG SOCKETS SOLID 16-20AWG WIRE 6mm
114017	24 SEALING PLUGS SIZE 12-16 CAVITIES 12-18 AWG
DRC16-40S	40-PIN PLUG, No Key
DT06-08SA	DT SERIES PLUG 8 CONTACT
W8S	WEDGELOCK FOR DT 8 PIN PLUG

These items are also available from a local Deutsch IPD distributor.

A crimping tool from Deutsch IPD is required to connect wiring to the sockets, P/N: HDT 48-00 or equivalent (not supplied).

1.5. Installation Instructions

NOTES & WARNINGS

- Do not install near high-voltage or high-current devices.
- Ground the chassis for safety purposes and proper EMI shielding.
- Note the operating temperature range. All field wiring must be suitable for that temperature range.
- Install the unit with appropriate space available for servicing and for adequate wire harness access (15 cm) and strain relief (30 cm).
- Do not connect or disconnect the unit while the circuit is live, unless the area is known to be non-hazardous.

MOUNTING

The module is designed for mounting on the engine. If it is mounted without an enclosure, the RTD Scanner should be mounted vertically with connectors facing left and right to reduce likelihood of moisture entry.

The RTD wires and CAN communication cable are considered intrinsically safe. The power wires are not considered intrinsically safe.

Mask all labels if the unit is to be repainted, so label information remains visible.

Mounting ledges include holes sized for M6 or ¼ inch bolts. The bolt length will be determined by the end-user's mounting plate thickness. Typically 20 mm (3/4 inch) is adequate.

If the module is mounted off-engine, no wire or cable in the harness should exceed 30 meters in length. The power input wiring should be limited to 10 meters.

CONNECTIONS

Use the following Deutsch IPD mating sockets to connect to the integral receptacles. Refer to the Dimensions and Pinout section for details on the Axiomatic mating plug kit P/N: AX070200. Wiring to these mating plugs must be in accordance with all applicable local codes. Suitable field wiring for the rated voltage and current must be used. The rating of the connecting cables must be at least 85°C. For ambient temperatures below -10°C and above +70°C, use field wiring suitable for both minimum and maximum ambient temperature.

Receptacle	Mating Socket (Refer to www.laddinc.com for more information on the wedgelock and contacts for this mating plug.)
Power and CAN bus: DT13-08PA	DT06-08SA
RTD Interface Receptacle: DRC13-40PA	DRC16-40SA DRC18-40SA

NOISE – ELECTRICAL CONNECTIONS

To reduce noise, separate all RTD wires from power wires. Shielded RTD wires will protect against ignition and injector noise.

GROUNDING

Protective Earth (PE) must be connected to the module's grounding lug to reduce the risk of electric shock. The conductor providing the connection must have a ring lug and wire larger than or equal to 4 mm² (12 AWG). The ring lug should be placed between the nut and a star washer.

All chassis grounding should go to a single ground point designated for the engine and all related equipment.

The ground strap that provides a low impedance path for EMI should be a ½ inch wide, flat, hollow braid, no more than 12 inches long with a suitable sized ring lug for the module's grounding lug. It may be used in place of the PE grounding conductor and would then perform both PE and EMI grounding functions.

SHIELDING

The RTD and CAN wiring should be shielded using a twisted conductor pair. All RTD wire shields should be terminated on the shield wire available on the 40-pin connector. The RTD wires should not be exposed for more than 50 mm (2 inches) without shielding. The shield may be cut off at the RTD end as it does not require termination at that end.

Shields can be AC grounded at one end and hard grounded at the opposite end to improve shielding effectiveness.

If the module is installed in a cabinet, shielded wiring can be terminated at the cabinet (earth ground), at the entry to the cabinet or at the RTD Scanner.

INPUT POWER

The main input to the power supply must be of low-impedance type for proper operation. If batteries are used, an alternator or other battery-charging device is necessary to maintain a stable supply voltage.

Central suppression of any surge events should be provided at the system level.

The installation of the equipment must include overcurrent protection between the power source and the RTD Scanner by means of a series connection of properly rated fuses or circuit breakers. Input power switches must be arranged external to the RTD Scanner.

The power input wiring should be limited to 10 meters.

Note the operating temperature range. All field wiring must be suitable for that temperature range.

RTD INPUT WIRING

Wiring for the RTD input must be shielded cable, 16 or 18 AWG. Cable lengths should be less than 30 meters. Shielding should be unbroken.

CAN WIRING

The CAN port is electrically isolated from all other circuits. The isolation is SELV rated with respect to product safety requirements. Refer to the CAN specification for more information.

Use CAN compatible cabling. J1939 cable is recommended as it is rated for on-engine use.

Shielded CAN cable is required. The RTD Scanner provides the CAN port shield connection ac coupled to chassis ground. The chassis ground stud located on the mounting foot must be tied directly to Earth Ground.

FUSING

When installing the unit, an external 3A, 32Vdc fuse is required.

NETWORK CONSTRUCTION

Axiomatic recommends that multi-drop networks be constructed using a “daisy chain” or “backbone” configuration with short drop lines.

TERMINATION

It is necessary to terminate the network. An external CAN termination is required. No more than 2 network terminations are recommended on any one network. Termination is a 121 Ohm, 0.25 W, 1% metal film resistor placed between CAN_H and CAN_L terminals at the end two units on the network.

2. DIAGNOSTIC MESSAGES

Each RTD channel could be configured to send diagnostic messages to the network if the temperature goes out of range, as described below.

When sending an “Active Diagnostic Trouble Code” (DM1) or a “Previously Active Diagnostic Trouble Codes” (DM2) message, the controller will use the appropriate Diagnostic Trouble Code (DTC). As defined by the standard, this is a combination of the Suspect Parameter Number (SPN), the Failure Mode Indicator (FMI), Occurrence Count (OC) and the SPN Conversion Method (CM).

The CM used by the Axiomatic controller is the recommend setting of 0. The SPN is a configurable setpoint, as described in section [3.1](#). Each channel will be associated with the four different FMIs, as described in sections [2.1](#). The OC for any DTC will be stored in a non-volatile diagnostic log, as described in section [2.2](#).

Regardless of whether or not there are any active DTCs, the ECU will send a DM1 message every one second as per the standard. If a previously inactive DTC becomes active, a DM1 will be sent immediately to reflect this. As soon as the last active DTC goes inactive, it will send a DM1 indicating that there are no more active DTCs.

If there is more than one active DTC at any given time, the regular DM1 message will be sent using a multipacket Broadcast Announce Message (BAM). If the controller receives a request for a DM1 while this is true, it will send the multipacket message to the Requester Address using the Transport Protocol (TP).

Previously active DTCs (a non-zero OC) are available upon request for a DM2 message. If there is more than one previously active DTC, the multipacket DM2 will be sent to the Requester Address using the Transport Protocol (TP).

See section [3.1](#) for a complete description of the J1939 Diagnostic setpoints and how changing them will affect if and how Diagnostic Messages (DM) will be sent to the J1939 bus.

2.1. Supported FMIs

By default, here are five different FMIs that are associated with each RTD channel.

FMI#	FMI Name (J1939)	AXRTD8 Function
0	Data Valid But Above Normal Operational Range – Most Severe	High Temperature Shutdown
15	Data Valid But Above Normal Operational Range – Least Severe	High Temperature Warning
17	Data Valid But Below Normal Operational Range – Least Severe	Low Temperature Warning
4	Current Above Normal or Short Circuit	RTD Short Circuit
5	Current Below Normal or Open Circuit	RTD Open Circuit

In the case of High Temperature Shutdown, the *Red Stop Lamp* will be set. In all other cases, the *Amber Warning Lamp* will be set. It is possible to have both a High Temperature Warning and a High Temperature Shutdown active simultaneously on the same SPN, in which case both lamps would be set. Short Circuit and Open Circuit diagnostics have user selectable FMI and diagnostic lamp settings as described in section [3.1](#).

2.2. Diagnostic Log

In order to support requests for DM2, the controller stores diagnostic data in a non-volatile log. There are four diagnostic log entries associated with each input channel. Each entry is a record of the SPN, FMI and OC for any fault that has occurred.

If the “Generate Diagnostic Messages” setpoint for the RTD channel is set to false, the OC for any DTCs for that channel will NOT be updated in the log, even if the controller detects the associated fault.

As soon as the controller detects a new (previously inactive) fault, it will start decrementing the delay timer for that channel. If the fault has remained present during the delay time, then the controller will set the DTC to active, and will increment the OC in the log. A DM1 will immediately be generated that includes the new DTC. While there are any active DTCs, a DM1 will be sent every second, as per the standard.

If the controller receives a request for a “Diagnostic Data Clear/Reset for Previously Active DTCs” (DM3) it will clear the OC of ALL the inactive DTCs in the log. The OC for active diagnostics is not changed.

If the user changes the SPN associated with a RTD channel, the diagnostic entries for that channel are updated, and the OC for each type of fault is set to zero.

If more than one channel uses the same SPN, the occurrence count will only be incremented once, even if more than one channel detects the same fault at the same time.

2.3. Clearing Active DTCs

For a low temperature warning to be cleared, the temperature must go above the "Low Warning Temperature"+1°C. For a high temperature warning to be cleared, the temperature must go below the "High Warning Temperature"-1°C. For an open circuit to be cleared, a temperature within the RTD's range (dependent on type) must be measured.

For the above faults, all of which sets the *Amber Warning Lamp* when detected, if the fault goes away, then the controller automatically makes the SPN/FMI combination previously active, and will no longer include it in the DM1.

However, by default, for a channel that has made the high temperature shutdown active, and sets the *Red Stop Lamp*, the DTC is NOT automatically made inactive once the fault clears. (By having the temperature drop below the "High Shutdown Temperature"-1°C.) Instead, it can only be cleared upon request for a “Diagnostic Data Clear/Reset for Active DTCs” (DM11).

If desired, High Temperature Shutdown faults can be set to clear automatically when the fault goes away as described in section [3.2](#). Likewise, Short Circuit and Open Circuit faults can be set to be cleared only by DM11 message with setting described in section [3.1](#).

Upon receiving a request for a DM11, the controller will check the status of all the active DTCs that set the *Red Stop Lamp*. If the fault is still present, then the DTC remains active. Otherwise, the DTC is made previously active, and it is no longer included in the DM1.

If any one of the *Red Stop Lamp* channels still has an active fault when the request for the DM11 is received, the controller will respond with a NAK, indicating that it was not able to complete the request. If, however, all the DTCs have now been made previously active, then it will respond with an ACK.

If all the faults in the module are cleared at this point, i.e. all DTCs are now inactive, the controller will send a DM1 message indicating that there are no longer any active DTCs.

3. ECU SETPOINTS

3.1. RTD Setpoints

There are only two setpoints per channel that determine how data is measured and sent to the bus. The other eight setpoints are associated with if and how the ECU will send diagnostic messages for that channel.

Name	Range	Default	Notes
Temperature Suspect Parameter Number	See Table 1	RTD1 = 1137 RTD2 = 1138 RTD3 = 1139 RTD4 = 1140 RTD5 = 1141 RTD6 = 1142 RTD7 = 1143 RTD8 = 1144	Exhaust Gas Port 1 Exhaust Gas Port 2 Exhaust Gas Port 3 Exhaust Gas Port 4 Exhaust Gas Port 5 Exhaust Gas Port 6 Exhaust Gas Port 7 Exhaust Gas Port 8
RTD Type	Disabled 2-Wire 3-Wire 4-Wire	3-Wire	
RTD Coefficient	IEC 0.00385 JIS 0.003916 US 0.003902 Legacy 0.003920 SAMA 0.003923 User Defined	IEC 0.00385	The User Defined option allows the Callendar Van Dusen constants to be set to whatever is defined for the sensor connected. Otherwise, each type has the constants pre-set as per the specification for the sensor.
Callendar Van Dusen Constant A	-10 to 10	3.908300	E-03, see below
Callendar Van Dusen Constant B	-10 to 10	-5.77500	E-07, see below
Callendar Van Dusen Constant C	-10 to 10	-4.183010	E-012, see below
Generate Diagnostic Messages	FALSE TRUE	TRUE	If set to false, no diagnostic messages will be sent to the bus for this channel, even if a fault is detected.
High Shutdown Temperature	Low Warning Temp to 1735°C	250.0°C	If the measured temperature is greater than or equal to this value, FMI=0 will be come active after the timeout period.
High Warning Temperature	Low Warning Temp to 1735°C	125.0°C	If the measured temperature is greater than or equal to this value, FMI=15 will be come active after the timeout period.
Low Warning Temperature	-200°C to High Warning Temp	-20°C	If the measured temperature is less than or equal to this value, FMI=17 will be come active after the timeout period.
High Shutdown Delay	0 to 60 Seconds	5.000 Sec	If a temperature goes above the " High Shutdown Temperature" and stays above it for this length of time, the fault becomes active.
High Warning Delay	0 to 60 Seconds	5.000 Sec	If a temperature goes above the " High Warning Temperature" and stays above it for this length of time, the fault becomes active.
Low Warning	0 to 60 Seconds	5.000 Sec	If a temperature goes below the " High

Delay			Warning Temperature" and stays above it for this length of time, the fault becomes active.
Open Circuit Delay	0 to 60 Seconds	1.000 Sec	If an open circuit is measured and stays present for this length of time, the fault becomes active.
Open Circuit Diag Enabled	FALSE TRUE	TRUE	If set to false, event is not included in diagnostic message, even if a fault is detected.
Open Circuit Lamp	Protect Amber, Warning Red, Stop Malfunction	Amber, Warning	
Open Circuit FMI	See Table 2	5	Current Below Normal Or Open Circuit
Open Circuit Event Cleared Only by DM11	FALSE TRUE	FALSE	If set to true, fault is cleared only by DM11 message.
Short Circuit Delay	0 to 60 Seconds	1.000 Sec	If a short circuit is measured and stays present for this length of time, the fault becomes active.
Short Circuit Diag Enabled	FALSE TRUE	TRUE	If set to false, event is not included in diagnostic message, even if a fault is detected.
Short Circuit Lamp	Protect Amber, Warning Red, Stop Malfunction	Amber, Warning	
Short Circuit FMI	See Table 2	4	Voltage Below Normal, Or Shorted To Low Source
Short Circuit Event Cleared Only by DM11	FALSE TRUE	FALSE	If set to true, fault is cleared only by DM11 message.

The RTD Scanner calculates the temperature from the measured resistance using Callendar Van Dusen constants. According to IEC751, the non-linearity of the platinum thermometer can be expressed as:

$$R_t = R_0[1 + At + Bt^2 + C(t-100)t^3] \quad \text{in which } C \text{ is only applicable when } t < 0 \text{ } ^\circ\text{C}.$$

The coefficients A, B, and C for a standard sensor are stated in IEC751.

The following setpoints are only available if the "Temperature Suspect Parameter Number" is set to 0 = Undefined (User Selectable). When this is true, diagnostic trouble codes in DM1 or DM2 messages will be created using the "Customized SPN" setpoint.

Transmit PGN	0 to 65535	65280 + Channel Number - 1	The Channel 1 default is the start of the Proprietary B PGN range.
Transmit Repetition Rate	0 to 60000 ms	0 ms	Default 0 ms means that the data will not be transmitted. Available only on request
Transmit Message Priority	0 to 7	6	Default priority for PropB messages
Destination Address (for PDU1)	0 to 255	254 (0xFE)	Not used by default, NULL address

Transmit Data Size	4 or 5	5 = 2-Bytes	Only 1 or 2 Byte data is supported
Transmit Data Index in Array (LSB)	1 to 8-Number of Data Bytes	1	Indexed from 1
Customized SPN (for Diagnostics)	1 to 524287	520192 + Channel Number - 1	The Channel 1 default 520192 = 0x7F000 is the start of the Proprietary SPN range

Table 1: Supported Suspect Parameter Numbers

SPN	Description	Size	PGN	Rate	Index	Priority
52	Engine Intercooler Temperature	1	65262	1000	7	6
75	Steering Axle Temperature	1	65273	1000	1	6
79	Road Surface Temperature	2	65269	1000	7	6
90	Power Takeoff Oil Temperature	1	65264	100	1	6
105	Engine Intake Manifold 1 Temperature	1	65270	500	3	6
110	Engine Coolant Temperature	1	65262	1000	1	6
120	Hydraulic Retarded Oil Temperature	1	65275	1000	2	6
169	Cargo Ambient Temperature	2	65276	1000	5	6
170	Cab Interior Temperature	2	65269	1000	2	6
171	Ambient Air Temperature	2	65269	1000	4	6
172	Engine Air Inlet Temperature	1	65269	1000	6	6
173	Engine Exhaust Gas Temperature	2	65270	500	6	6
174	Engine Fuel Temperature 1	1	65262	1000	2	6
175	Engine Oil Temperature 1	2	65262	1000	3	6
176	Engine Turbocharger Oil Temperature	2	65262	1000	5	6
177	Transmission Oil Temperature	2	65272	1000	5	6
242	Tire Temperature	2	65268	10000	3	6
412	Engine Exhaust Gas Recirculation 1 Temperature	2	65188	1000	7	6
441	Auxiliary Temperature 1	1	65164	0	1	7
442	Auxiliary Temperature 2	1	65164	0	2	7
578	Drive Axle Temperature	1	65273	1000	4	6
1122	Engine Alternator Bearing 1 Temperature	1	65191	1000	1	7
1123	Engine Alternator Bearing 2 Temperature	1	65191	1000	2	7
1124	Engine Alternator Winding 1 Temperature	1	65191	1000	3	7
1125	Engine Alternator Winding 2 Temperature	1	65191	1000	4	7
1126	Engine Alternator Winding 3 Temperature	1	65191	1000	5	7
1131	Engine Intake Manifold 2 Temperature	1	65189	500	1	6
1132	Engine Intake Manifold 3 Temperature	1	65189	500	2	6
1133	Engine Intake Manifold 4 Temperature	1	65189	500	3	6
1135	Engine Oil Temperature 2	2	65188	1000	1	6
1136	Engine ECU Temperature	2	65188	1000	3	6
1137	Engine Exhaust Gas Port 1 Temperature	2	65187	1000	1	6
1138	Engine Exhaust Gas Port 2 Temperature	2	65187	1000	3	6
1139	Engine Exhaust Gas Port 3 Temperature	2	65187	1000	5	6
1140	Engine Exhaust Gas Port 4 Temperature	2	65187	1000	7	6
1141	Engine Exhaust Gas Port 5 Temperature	2	65186	1000	1	6
1142	Engine Exhaust Gas Port 6 Temperature	2	65186	1000	3	6
1143	Engine Exhaust Gas Port 7 Temperature	2	65186	1000	5	6
1144	Engine Exhaust Gas Port 8 Temperature	2	65186	1000	7	6
1145	Engine Exhaust Gas Port 9 Temperature	2	65185	1000	1	6
1146	Engine Exhaust Gas Port 10 Temperature	2	65185	1000	3	6
1147	Engine Exhaust Gas Port 11 Temperature	2	65185	1000	5	6
1148	Engine Exhaust Gas Port 12 Temperature	2	65185	1000	7	6
1149	Engine Exhaust Gas Port 13 Temperature	2	65184	1000	1	6
1150	Engine Exhaust Gas Port 14 Temperature	2	65184	1000	3	6
1151	Engine Exhaust Gas Port 15 Temperature	2	65184	1000	5	6
1152	Engine Exhaust Gas Port 16 Temperature	2	65184	1000	7	6
1153	Engine Exhaust Gas Port 17 Temperature	2	65183	1000	1	6
1154	Engine Exhaust Gas Port 18 Temperature	2	65183	1000	3	6

1155	Engine Exhaust Gas Port 19 Temperature	2	65183	1000	5	6
1156	Engine Exhaust Gas Port 20 Temperature	2	65183	1000	7	6
1157	Engine Main Bearing 1 Temperature	2	65182	1000	1	6
1158	Engine Main Bearing 2 Temperature	2	65182	1000	3	6
1159	Engine Main Bearing 3 Temperature	2	65182	1000	5	6
1160	Engine Main Bearing 4 Temperature	2	65182	1000	7	6
1161	Engine Main Bearing 5 Temperature	2	65181	1000	1	6
1162	Engine Main Bearing 6 Temperature	2	65181	1000	3	6
1163	Engine Main Bearing 7 Temperature	2	65181	1000	5	6
1164	Engine Main Bearing 8 Temperature	2	65181	1000	7	6
1165	Engine Main Bearing 9 Temperature	2	65180	1000	1	6
1166	Engine Main Bearing 10 Temperature	2	65180	1000	3	6
1167	Engine Main Bearing 11 Temperature	2	65180	1000	5	6
1172	Engine Turbocharger 1 Compressor Inlet Temperature	2	65178	1000	1	6
1173	Engine Turbocharger 2 Compressor Inlet Temperature	2	65178	1000	3	6
1174	Engine Turbocharger 3 Compressor Inlet Temperature	2	65178	1000	5	6
1175	Engine Turbocharger 4 Compressor Inlet Temperature	2	65178	1000	7	6
1180	Engine Turbocharger 1 Turbine Inlet Temperature	2	65176	1000	1	6
1181	Engine Turbocharger 2 Turbine Inlet Temperature	2	65176	1000	3	6
1182	Engine Turbocharger 3 Turbine Inlet Temperature	2	65176	1000	5	6
1183	Engine Turbocharger 4 Turbine Inlet Temperature	2	65176	1000	7	6
1184	Engine Turbocharger 1 Turbine Outlet Temperature	2	65175	1000	1	6
1185	Engine Turbocharger 2 Turbine Outlet Temperature	2	65175	1000	3	6
1186	Engine Turbocharger 3 Turbine Outlet Temperature	2	65175	1000	5	6
1187	Engine Turbocharger 4 Turbine Outlet Temperature	2	65175	1000	7	6
1212	Engine Auxiliary Coolant Temperature	1	65172	500	2	6
1636	Engine Intake Manifold 1 Air Temperature (High Resolution)	2	65129	1000	1	6
1637	Engine Coolant Temperature (High Resolution)	2	65129	1000	3	6
1638	Hydraulic Temperature	1	65128	1000	1	6
1687	Auxiliary Heater Outlet Coolant Temperature	1	65133	1000	1	6
1688	Auxiliary Heater Input Air Temperature	1	65133	1000	2	6
1800	Battery 1 Temperature	1	65104	1000	1	6
1801	Battery 2 Temperature	1	65104	1000	2	6
1802	Engine Intake Manifold 5 Temperature	1	65189	500	4	6
1803	Engine Intake Manifold 6 Temperature	1	65189	500	5	6
2433	Engine Exhaust Gas Temperature - Right Manifold	2	65031	500	1	6
2434	Engine Exhaust Gas Temperature - Left Manifold	2	65031	500	3	6
2629	Engine Turbocharger 1 Compressor Outlet Temperature	2	64979	1000	1	6
2630	Engine Charge Air Cooler 1 Outlet Temperature	2	65129	1000	7	6
2799	Engine Turbocharger 2 Compressor Outlet Temperature	2	64979	1000	3	6
2800	Engine Turbocharger 3 Compressor Outlet Temperature	2	64979	1000	5	6
2801	Engine Turbocharger 4 Compressor Outlet Temperature	2	64979	1000	7	6
2986	Engine Intake Valve Actuation System Oil Temperature	2	65129	1000	5	6
3031	Aftertreatment 1 SCR Catalyst Tank Temperature	1	65110	1000	2	6
3241	Aftertreatment 1 Exhaust Gas Temperature 1	2	64948	500	1	6
3242	Aftertreatment 1 Diesel Particulate Filter Intake Gas Temperature	2	64948	500	3	6
3245	Aftertreatment 1 Exhaust Gas Temperature 3	2	64947	500	1	6
3246	Aftertreatment 1 Diesel Particulate Filter Outlet Gas Temperature	2	64947	500	3	6
3249	Aftertreatment 1 Exhaust Gas Temperature 2	2	64946	500	1	6
3250	Aftertreatment 1 Diesel Particulate Filter Intermediate Gas Temperature	2	64946	500	3	6

3275	Aftertreatment 2 Exhaust Gas Temperature 1	2	64945	500	1	6
3276	Aftertreatment 2 Diesel Particulate Filter Intake Gas Temperature	2	64945	500	3	6
3279	Aftertreatment 2 Exhaust Gas Temperature 3	2	64944	500	1	6
3280	Aftertreatment 2 Diesel Particulate Filter Outlet Gas Temperature	2	64944	500	3	6
3283	Aftertreatment 2 Exhaust Gas Temperature 2	2	64943	500	1	6
3284	Aftertreatment 2 Diesel Particulate Filter Intermediate Gas Temperature	2	64943	500	3	6
3468	Engine Fuel Temperature 2	1	64930	500	5	4
3515	Aftertreatment 1 SCR Catalyst Reagent Temperature 2	1	64923	1000	1	6
3823	Transmission Torque Converter Oil Outlet Temperature	2	64917	1000	2	6
3831	Aftertreatment 1 Secondary Air Temperature	2	64877	500	3	6
3834	Aftertreatment 2 Secondary Air Temperature	2	64876	500	3	6
4076	Engine Coolant Temperature 2	1	64870	1000	1	6
4151	Engine Exhaust Gas Temperature Average	2	64851	500	1	5
4152	Engine Exhaust Gas Temperature Average - Bank 2	2	64851	500	3	5
4153	Engine Exhaust Gas Temperature Average - Bank 1	2	64851	500	5	5
4193	Engine Coolant Pump Outlet Temperature	1	64870	1000	2	6
4288	Engine Exhaust Valve Actuation System Oil Temperature	2	64870	1000	4	6
4289	Aftertreatment 1 Three Way Catalytic Converter Intake Gas Temperature	2	64838	500	1	6
4290	Aftertreatment 1 Three Way Catalytic Converter Outlet Gas Temperature	2	64838	500	3	6
4295	Aftertreatment 2 Three Way Catalytic Converter Intake Gas Temperature	2	64837	500	1	6
4296	Aftertreatment 2 Three Way Catalytic Converter Outlet Gas Temperature	2	64837	500	3	6
4337	Aftertreatment 1 SCR Dosing Reagent Temperature	1	64833	500	3	6
4360	Aftertreatment 1 SCR Catalyst Intake Gas Temperature	2	64830	500	1	6
4363	Aftertreatment 1 SCR Catalyst Outlet Gas Temperature	2	64830	500	4	6
4368	Aftertreatment 1 SCR Catalyst Reagent Tank 2 Temperature	1	64829	1000	2	6
4390	Aftertreatment 2 SCR Dosing Reagent Temperature	1	64827	500	3	6
4413	Aftertreatment 2 SCR Catalyst Intake Gas Temperature	2	64824	500	1	6
4415	Aftertreatment 2 SCR Catalyst Outlet Gas Temperature	2	64824	500	4	6
4420	Aftertreatment 2 SCR Catalyst Reagent Temperature 2	1	64822	1000	1	6
4427	Aftertreatment 2 SCR Catalyst Tank Temperature	1	64821	1000	2	6
4434	Aftertreatment 2 SCR Catalyst Reagent Tank 2 Temperature	1	64820	1000	2	6
4750	Engine Exhaust Gas Recirculation 1 (EGR1) Cooler Intake Temperature	2	64879	0	3	6
4753	Aftertreatment 1 Gas Oxidation Catalyst Intake Gas Temperature	2	64802	500	1	6
4754	Aftertreatment 1 Gas Oxidation Catalyst Outlet Gas Temperature	2	64802	500	3	6
4759	Aftertreatment 2 Gas Oxidation Catalyst Intake Gas Temperature	2	64801	500	1	6
4760	Aftertreatment 2 Gas Oxidation Catalyst Outlet Gas Temperature	2	64801	500	3	6
4765	Aftertreatment 1 Diesel Oxidation Catalyst Intake Gas Temperature	2	64800	500	1	6
4766	Aftertreatment 1 Diesel Oxidation Catalyst Outlet Gas Temperature	2	64800	500	3	6
4771	Aftertreatment 2 Diesel Oxidation Catalyst Intake Gas Temperature	2	64799	500	1	6
4772	Aftertreatment 2 Diesel Oxidation Catalyst Outlet Gas Temperature	2	64799	500	3	6
4809	Aftertreatment 1 Warm Up Diesel Oxidation Catalyst Intake Temperature	2	64794	500	1	6
4810	Aftertreatment 1 Warm Up Diesel Oxidation Catalyst Outlet Temperature	2	64794	500	3	6
5020	Engine Exhaust Gas Recirculation 1 (EGR1) Mixer Intake Temperature	2	64870	1000	6	6
5148	Low Voltage Disconnect Temperature	1	64769	500	4	6
5255	Engine Exhaust Gas Recirculation 2 (EGR2) Temperature	2	64767	1000	1	6
5256	Engine Exhaust Gas Recirculation 2 (EGR2) Mixer Intake Temperature	2	64767	1000	3	6
5258	Engine Exhaust Gas Recirculation 2 (EGR2) Cooler Intake Temperature	2	64766	0	1	6
5280	Engine Charge Air Cooler 1 Precooler Intake Temperature	2	64759	1000	1	6
5281	Engine Charge Air Cooler 1 Precooler Outlet Temperature	2	64759	1000	3	6
5283	Engine Charge Air Cooler 1 Intake Temperature	2	64758	1000	1	6

5284	Engine Charge Air Cooler 1 Ambient Air Temperature	2	64758	1000	3	6
5286	Engine Charge Air Cooler 2 Precooler Intake Temperature	2	64757	1000	1	6
5287	Engine Charge Air Cooler 2 Precooler Outlet Temperature	2	64757	1000	3	6
5289	Engine Charge Air Cooler 2 Intake Temperature	2	64756	1000	1	6
5290	Engine Charge Air Cooler 2 Outlet Temperature	2	64756	1000	3	6
5291	Engine Charge Air Cooler 2 Ambient Air Temperature	2	64756	1000	5	6
5315	Aftertreatment 2 Warm Up Diesel Oxidation Catalyst Intake Temperature	2	64749	500	1	6
5316	Aftertreatment 2 Warm Up Diesel Oxidation Catalyst Outlet Temperature	2	64749	500	3	6
5456	Aftertreatment 1 Hydrocarbon Doser Intake Fuel Temperature	1	64869	500	6	6

Table 2: Supported FMIs

FMI#	FMI Name (J1939)
0	Data Valid But Above Normal Operational Range - Most Severe Level
1	Data Valid But Below Normal Operational Range - Most Severe Level
2	Data Erratic, Intermittent Or Incorrect
3	Voltage Above Normal, Or Shorted To High Source
4	Voltage Below Normal, Or Shorted To Low Source
5	Current Below Normal Or Open Circuit
6	Current Above Normal Or Grounded Circuit
7	Mechanical System Not Responding Or Out Of Adjustment
8	Abnormal Frequency Or Pulse Width Or Period
9	Abnormal Update Rate
10	Abnormal Rate Of Change
11	Root Cause Not Known
12	Bad Intelligent Device Or Component
13	Out Of Calibration
14	Special Instructions
15	Data Valid But Above Normal Operating Range - Least Severe Level
16	Data Valid But Above Normal Operating Range - Moderately Severe Level
17	Data Valid But Below Normal Operating Range - Least Severe Level
18	Data Valid But Below Normal Operating Range - Moderately Severe Level
19	Received Network Data In Error
20	Data Drifted High
21	Data Drifted Low
22	Reserved For SAE Assignment
23	Reserved For SAE Assignment
24	Reserved For SAE Assignment
25	Reserved For SAE Assignment
26	Reserved For SAE Assignment
27	Reserved For SAE Assignment
28	Reserved For SAE Assignment
29	Reserved For SAE Assignment
30	Reserved For SAE Assignment
31	Condition Exists

3.2. Miscellaneous Setpoints

NAME Setpoints

The AXRTD8 ECU has the following defaults for the J1939 NAME. The user should refer to the SAE J1939/81 standard for more information on these parameters and their ranges.

Arbitrary Address Capable	Yes
Industry Group	5, Industrial Process Control, Stationary (Gen-Sets)
Vehicle System Instance	0
Vehicle System	0, Non-specific system
Function	128, Supplemental Engine Control Sensing
Function Instance	5, AXRTD8, Eight RTD
ECU Instance	0, First Instance
Manufacture Code	162, Axiomatic Technologies Corporation
Identity Number	Variable, based on ECU Serial Number

The only configurable setpoint associated with the NAME is the ECU Instance. Changing this value will allow multiple ECUs of this type to be distinguishable by other ECUs (including Axiomatic Electronic Assistant[®]) when they are all connected on the same network.

ECU Address

With this setpoint, the user can change the address of the ECU. The default value of this setpoint is 235 (0xEB), Supplemental Sensor Processing Unit#1, as set by the SAE in J1939 tables B3 to B7. The EA will allow the selection of any address between 0 to 253, and ***it is the user's responsibility to select an address that complies with the standard.*** The user must also be aware that since the unit is arbitrary address capable, if another ECU with a higher priority NAME contends for the selected address, the module will continue select the next highest address until it finds one that it can claim. See J1939/81 for more details about address claiming.

Filter Frequency

As described in section [1.2](#), the analog-to-digital converter has programmable rejection for line frequency. This setpoint allows the user to select either 50Hz or 60Hz as appropriate, and has a default value of 60Hz.

Averaging Setpoints

If desired, averaging can be enabled such that the average temperature of all active channels, the average temperature of Bank 1 (channels 1 to 4), and the average temperature of Bank 2 (channels 5 to 8) can be broadcasted on the J1939 network. The PGN on which the data is sent, and the repetition rate at which is sent is user configurable. However, the structure of the data in the 'Averaging' message is fixed in the order shown below. All average temperatures are sent as WORD (2 byte) data with 0.03125°C/bit resolution and a -273°C offset.

PGN 64851 Engine Average Information			
Transmission Repetition:	500ms	(user configurable)	
Data Length:	8		
Data Page:	0		
PDU Format:	253		
PDU Specific:	83	PGN Supporting Information:	
Default Priority:	5		
Parameter Group Number:	64851 (0xFD53)	(user configurable)	
Start Position	Length	Parameter Name	SPN
1-2	2 bytes	Engine Exhaust Gas Temperature Average	4151
3-4	2 bytes	Engine Exhaust Gas Temperature Average – Bank 1	4153
5-6	2 bytes	Engine Exhaust Gas Temperature Average – Bank 2	4152

Name	Range	Default	Notes
Averaging Enabled	FALSE TRUE	FALSE	If set to false, the averaging message will not be sent to the bus.
Averaging PGN	0 to 65535	64851 (0xFD53)	Per J1939-71, January 2009
Averaging Repetition Rate	100ms to 60000 ms	500 ms	Determines how often the averaging message will be sent to the network
High Shutdown Event Cleared Only by DM11	FALSE TRUE	TRUE	Setpoint is mutual for all RTD channels

High Shutdown Event Cleared Only by DM11

If desired, all fault events can be set to clear automatically when the causing condition goes away, which eliminates the need to receive DM11 messages from the CAN bus. By default, the High Shutdown faults are cleared only by DM11 messages. If operating in a system where clearing faults with DM11 messages is inconvenient, the High Shutdown faults can be set to clear automatically, by setting "High Shutdown Event Cleared Inly by DM11" setpoint to FALSE. This setpoint is mutual for all RTD Channels, thus High Shutdown faults of all channels will act according to it.

4. USING ECU WITH AXIOMATIC ELECTRONIC ASSISTANT®

4.1. Installing the Electronic Assistant®

For instruction on how to install and use the Electronic Assistant® (EA), refer to User Manual AX07050x.

4.2. Screen Captures

Image 5.1: CAN port was opened, programmer has recognized the Axiomatic ECU

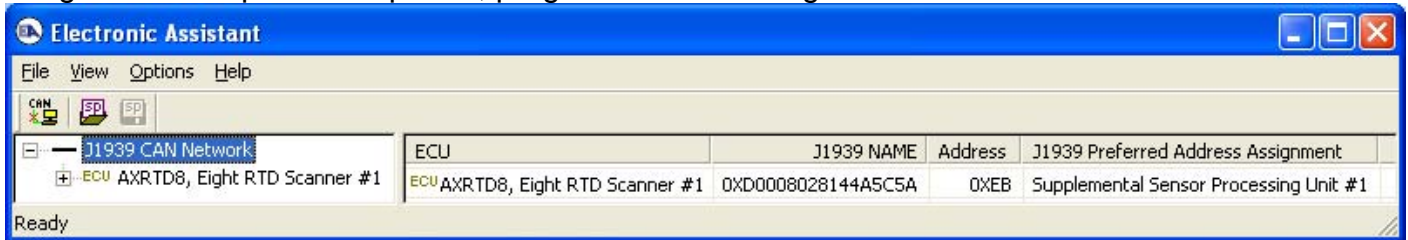
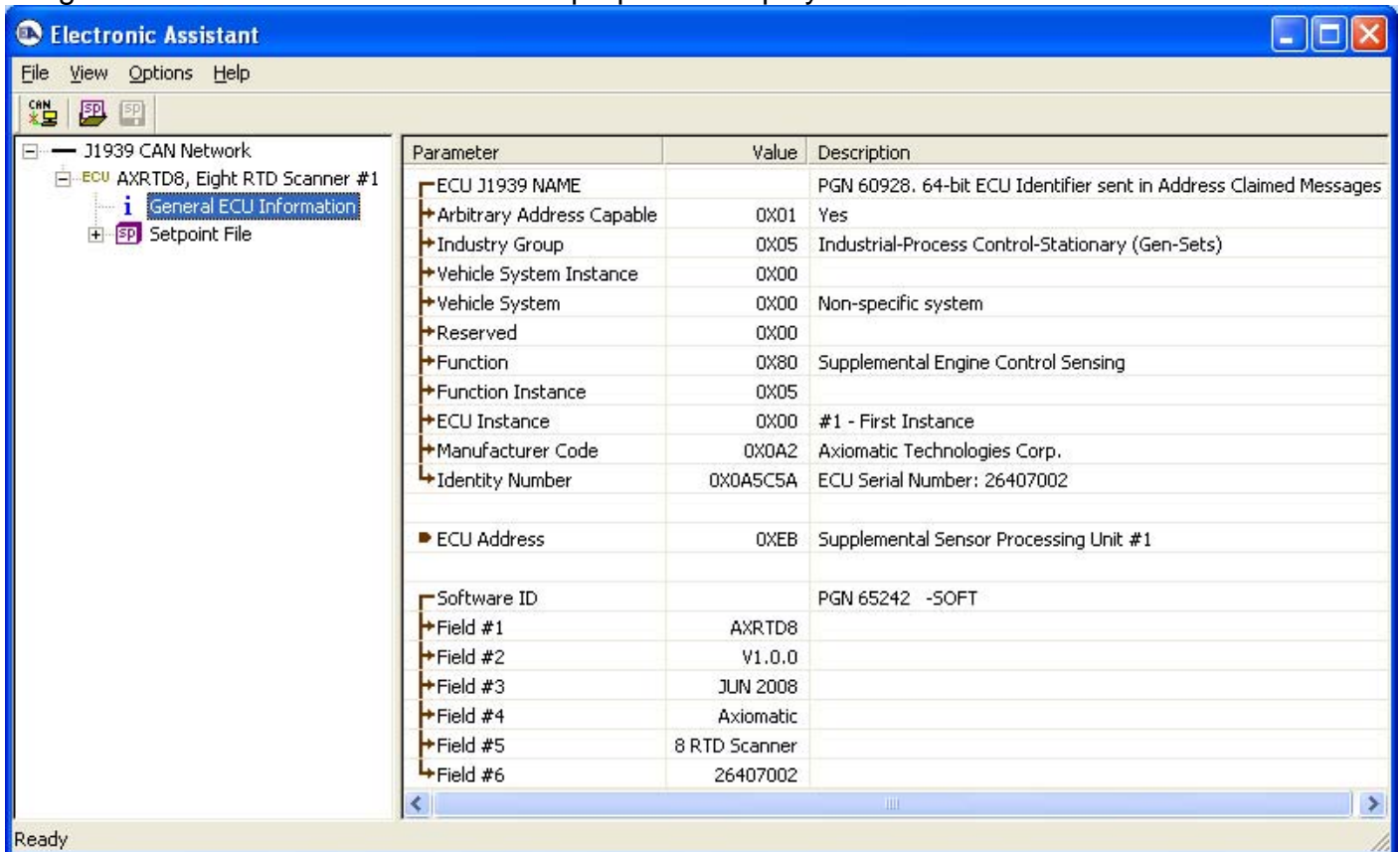

Image 5.2: ECU Name and Software ID properties displayed



For the AXRTD8 Software ID, the data in the fields are as follows:

(Part Number)*(Version)*(Date)*(Owner)*(Description)*(Serial Number)

Image 5.3: Miscellaneous Setpoints

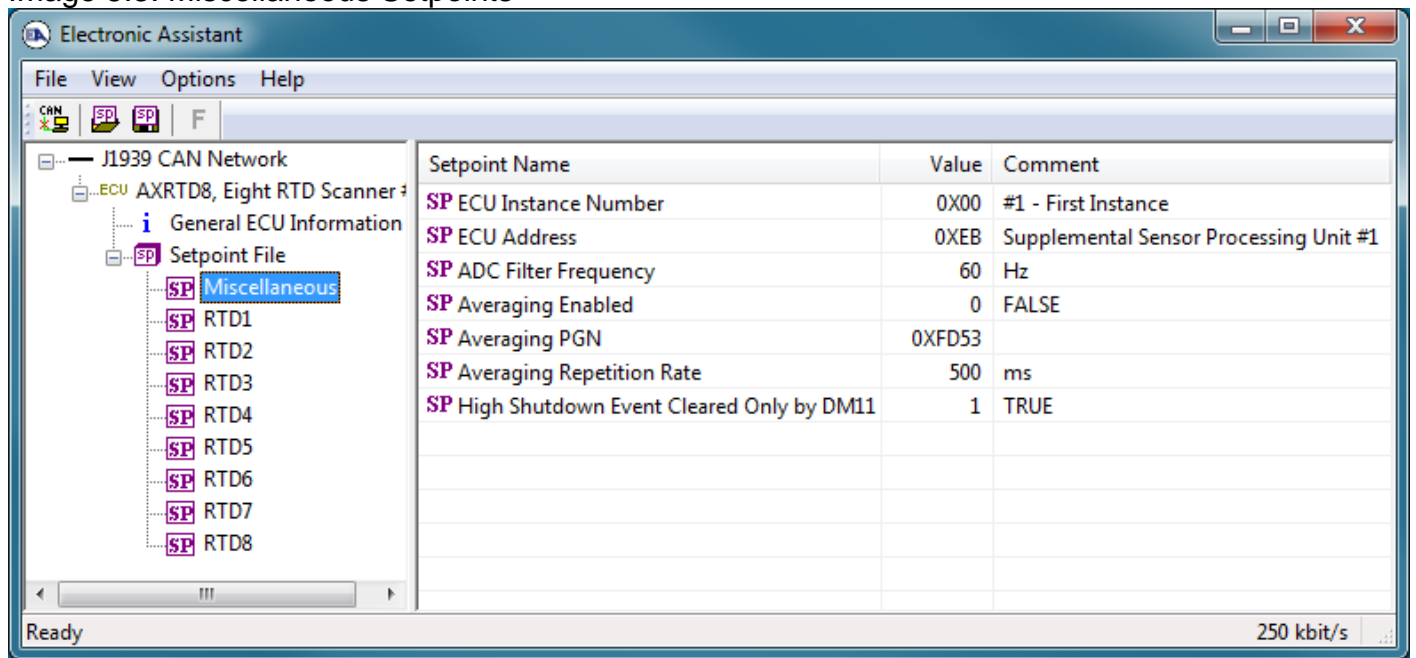

Image 5.4: Input Channel Setpoints – Defaults for Channel 1

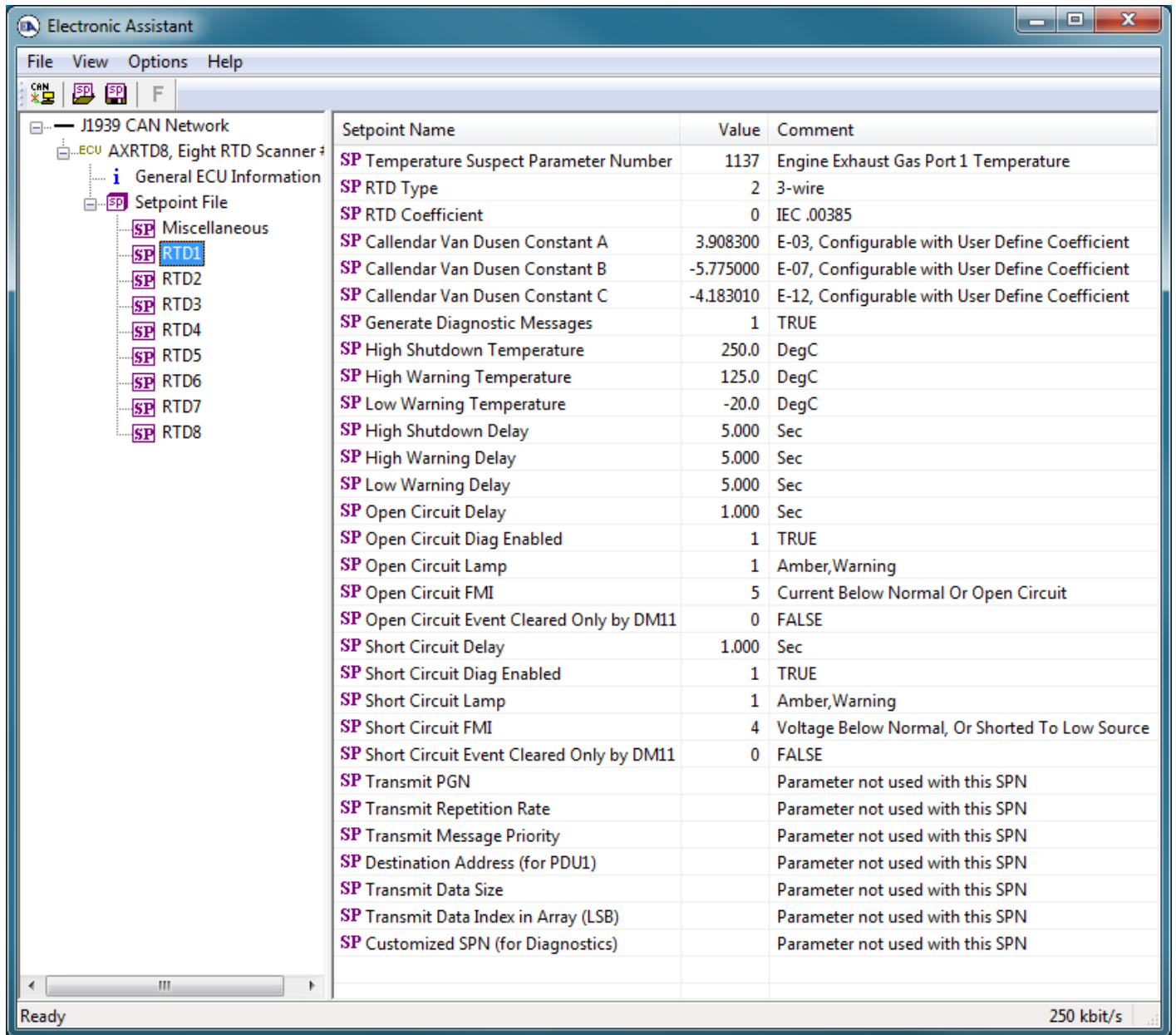

Image 5.5: Input Channel Setpoints – User Defined Defaults for Channel 1

Electronic Assistant

File View Options Help

CAN SP SP F

J1939 CAN Network

- ECU AXRTD8, Eight RTD Scanner #1
 - General ECU Information
 - Setpoint File
 - Miscellaneous
 - RTD1
 - RTD2
 - RTD3
 - RTD4
 - RTD5
 - RTD6
 - RTD7
 - RTD8

Setpoint Name	Value	Comment
SP Temperature Suspect Parameter Number	0	Undefined (User Selectable)
SP RTD Type	2	3-wire
SP RTD Coefficient	0	IEC .00385
SP Callendar Van Dusen Constant A	3.908300	E-03, Configurable with User Define Coefficient
SP Callendar Van Dusen Constant B	-5.775000	E-07, Configurable with User Define Coefficient
SP Callendar Van Dusen Constant C	-4.183010	E-12, Configurable with User Define Coefficient
SP Generate Diagnostic Messages	1	TRUE
SP High Shutdown Temperature	250.0	DegC
SP High Warning Temperature	125.0	DegC
SP Low Warning Temperature	-20.0	DegC
SP High Shutdown Delay	5.000	Sec
SP High Warning Delay	5.000	Sec
SP Low Warning Delay	5.000	Sec
SP Open Circuit Delay	1.000	Sec
SP Open Circuit Diag Enabled	1	TRUE
SP Open Circuit Lamp	1	Amber,Warning
SP Open Circuit FMI	5	Current Below Normal Or Open Circuit
SP Open Circuit Event Cleared Only by DM11	0	FALSE
SP Short Circuit Delay	1.000	Sec
SP Short Circuit Diag Enabled	1	TRUE
SP Short Circuit Lamp	1	Amber,Warning
SP Short Circuit FMI	4	Voltage Below Normal, Or Shorted To Low Sourc
SP Short Circuit Event Cleared Only by DM11	0	FALSE
SP Transmit PGN	0XFF00	
SP Transmit Repetition Rate	0	ms
SP Transmit Message Priority	6	
SP Destination Address (for PDU1)		Parameter not used with this PGN
SP Transmit Data Size	5	2-Bytes
SP Transmit Data Index in Array (LSB)	1	
SP Customized SPN (for Diagnostics)	0X0007F000	

Ready 250 kbit/s

5. USING RS-232 WITH TERA TERM

Additional information for diagnostics or testing is available through RS-232.

- Connect the DB-9 to a COM port on a PC or laptop. Use the following RS-232 connection.

8-Pin Connector		DB-9 Female	
Pin #	Controller Function	Pin #	PC Function
7	RS-232 Transmit	2	RS-232 Receive
8	RS-232 Receive	3	RS-232 Transmit
6	GND Reference	5	RS-232 GND

- Open Tera Term Pro, and set it up as shown in the steps below.
(Free downloadable from <http://logmett.com/index.php?/products/teraterm.html>)
- Select **Serial** with the appropriate COM port for your PC or laptop

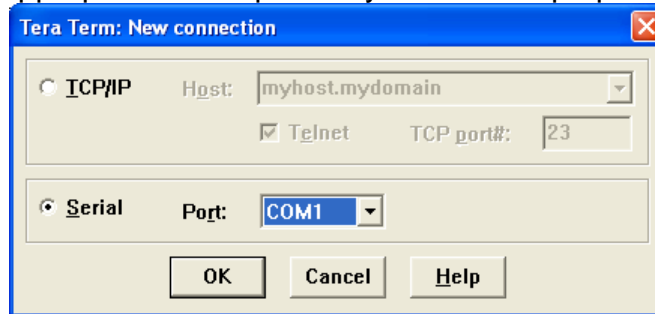

- Go to **Setup/Serial Port** and change the settings to exactly as shown below (other than Port)

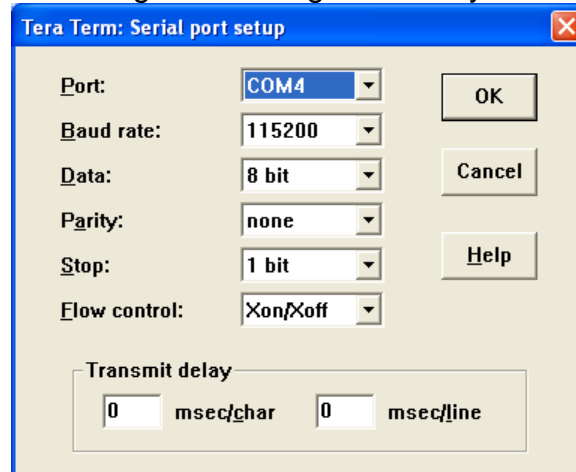

- Go to **Setup/Terminal** and verify that New-line Transmit and Receive are CR. The window size can be adjusted as desired by checking 'Term size = win size'

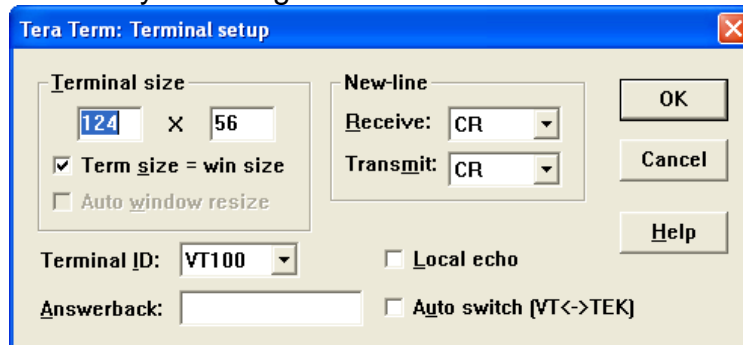

5.1. M – Main Menu Options

At power up, the Main Menu will be displayed, after the power up banner has been printed. If at any time you wish to see the menu again, simply hit 'm' or 'M' and it will be reprinted.

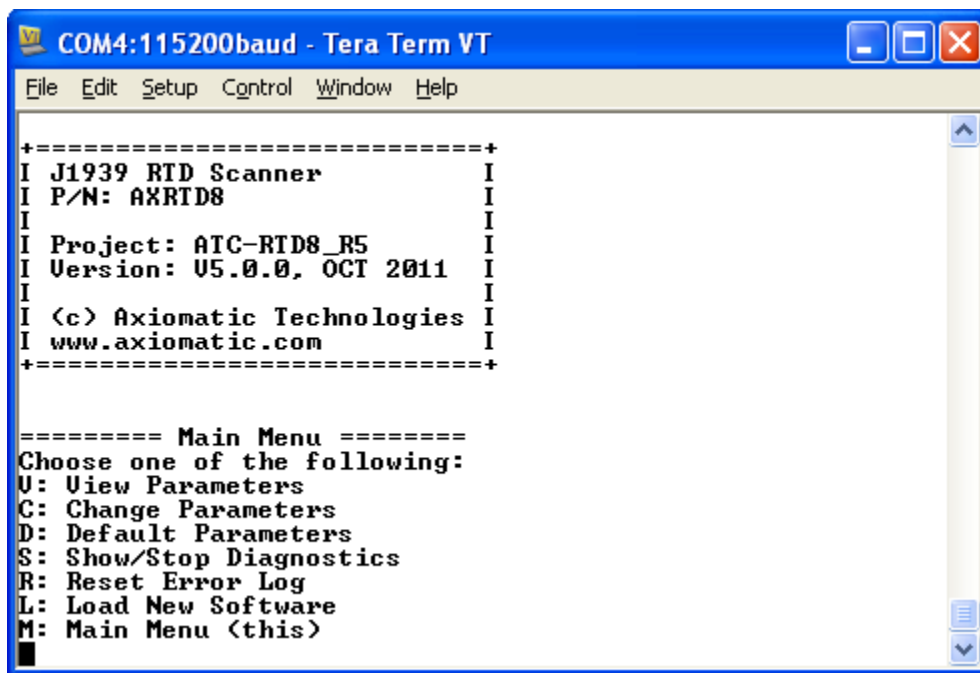

The screenshot shows a terminal window titled "COM4:115200baud - Tera Term VT". The window has a menu bar with "File", "Edit", "Setup", "Control", "Window", and "Help". The main content area displays a series of status messages followed by a "Main Menu" screen. The status messages are enclosed in a dashed border and include: "I J1939 RTD Scanner", "I P/N: AXRTD8", "I Project: ATC-RTD8_R5", "I Version: V5.0.0, OCT 2011", "I <c> Axiomatic Technologies", and "I www.axiomatic.com". Below these messages, the "Main Menu" is displayed, starting with "=====
Main Menu =====
Choose one of the following:
U: View Parameters
C: Change Parameters
D: Default Parameters
S: Show/Stop Diagnostics
R: Reset Error Log
L: Load New Software
M: Main Menu <this>
█".

5.2. V – View Parameters

Entering 'v' or 'V' from the main menu prints a list of available options to see. To view all of the setpoints on the unit at once, select '0' at the prompts, then keep hitting 'y' until all the setpoints have been displayed. To exit the loop at any time, hit any key other than 'y' or 'Y'.

Alternately, only one specific channel can be viewed at any given time by entering the appropriate number at the prompt "Enter channel to view:"

WARNING: While in the view sub-menu, all other operations including temperature scanning and CAN networking are halted. Do not use this feature when regular operating conditions are required.

```
COM3:115200baud - Tera Term VT
File Edit Setup Control Window Help
v
0: ViewAll
1: RTD1
2: RTD2
3: RTD3
4: RTD4
5: RTD5
6: RTD6
7: RTD7
8: RTD8
9: NAME
10: Address
11: ADCFilter
Enter channel to view: 0

ADCFilter = 60 [Hz]

RTD1 Parameters
ChannelSPN = 1137
RTD_Type = 3-wire
Coefficient = IEC .00385
CalVanDusen_A = 3.9083
CalVanDusen_B = -5.775
CalVanDusen_C = -4.18301
GenerateDiag = TRUE
ShutdownTemp = 2500 [DegC*10]
HighWarnTemp = 1250 [DegC*10]
LowWarnTemp = -200 [DegC*10]
ShutdownDelay = 5000 [ms]
HighWarnDelay = 5000 [ms]
LowWarnDelay = 5000 [ms]
OpenCctDelay = 1000 [ms]
OpenCctLamp = Amber,Warning
OpenCctFMI = Current Below Normal Or Open Circuit
OpenCctEnable = TRUE
OpenCctSticky = FALSE
ShortCctDelay = 1000 [ms]
ShortCctLamp = Amber,Warning
ShortCctFMI = Voltage Below Normal, Or Shorted To Low Source
ShortCctEnable = TRUE
ShortCctSticky = FALSE

RTD2 Parameters
ChannelSPN = 1138
RTD_Type = 3-wire
Coefficient = IEC .00385
CalVanDusen_A = 3.9083
CalVanDusen_B = -5.775
CalVanDusen_C = -4.18301
GenerateDiag = TRUE
ShutdownTemp = 2500 [DegC*10]
HighWarnTemp = 1250 [DegC*10]
LowWarnTemp = -200 [DegC*10]
ShutdownDelay = 5000 [ms]
HighWarnDelay = 5000 [ms]
LowWarnDelay = 5000 [ms]
OpenCctDelay = 1000 [ms]
OpenCctLamp = Amber,Warning
OpenCctFMI = Current Below Normal Or Open Circuit
OpenCctEnable = TRUE
OpenCctSticky = FALSE
ShortCctDelay = 1000 [ms]
ShortCctLamp = Amber,Warning
ShortCctFMI = Voltage Below Normal, Or Shorted To Low Source
ShortCctEnable = TRUE
ShortCctSticky = FALSE

RTD3 Parameters
```

View all setpoints

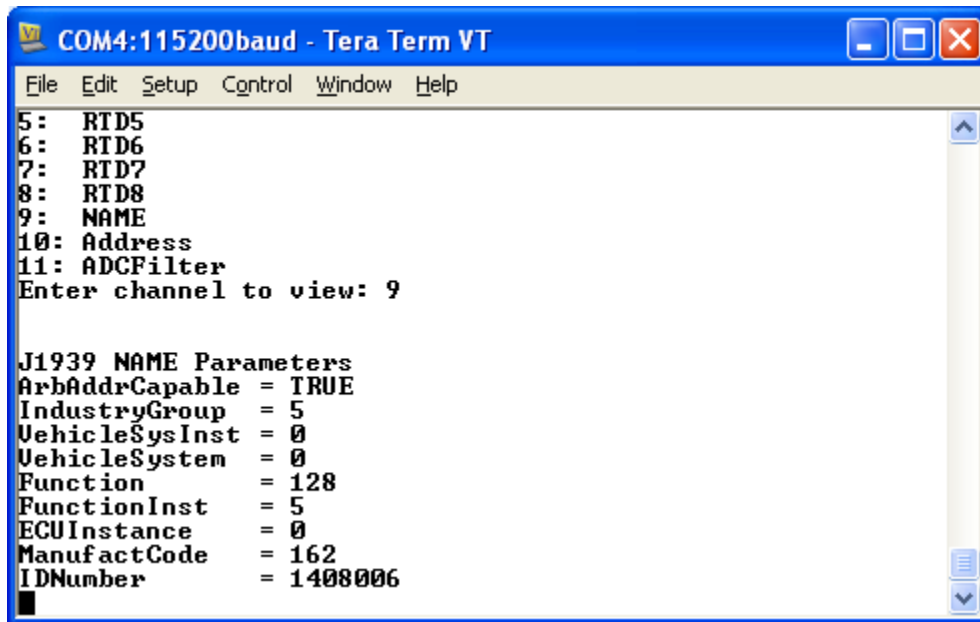

View specific setpoints

5.3. C – Change Parameters

It is recommended to not use this feature. Change setpoints only by using EA ® as described in Section 4 of this user manual.

5.4. D – Default Parameters

To reset all the setpoints back to their factory defaults, as described in this user manual, enter 'd' or 'D' from the main menu. At the prompt enter 'y' or 'Y' at the control will re-initialize its non-volatile memory to the default values, then reset the controller.

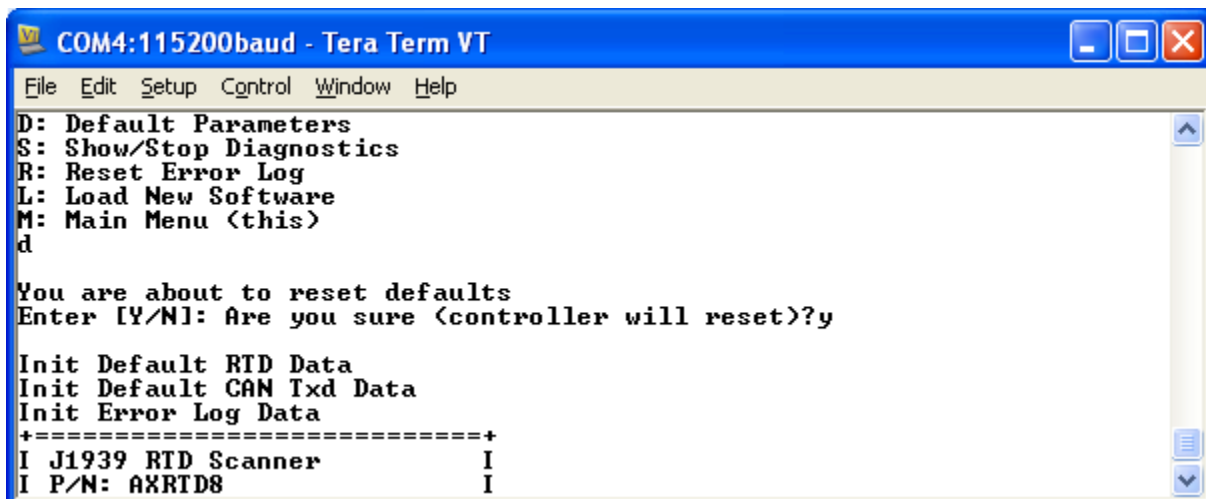

5.5. S – Show/Stop Diagnostics

A diagnostic option is available using the 's' or 'S' option. Once started, the diagnostic screen will be refreshed every 1 second until stopped. Please note, this option is only for manual diagnostics, and is not saved in non-volatile memory (i.e. the diagnostic screen is never displayed after a power cycle without the 's' entry)

```

COM4:115200baud - Tera Term VT
File Edit Setup Control Window Help
Ch   Type   Gain   RawDataLow   InputLow[uV]   Wire[Ohm]   Gain   RawDataHigh   InputHigh[uV]   Res[Ohm]   Temp[DegC]
RTD1 2-wire G64   0X00C729AC   21717         5.32964     G1    0X00987FA1   478487         117.424     45.4
RTD2 2-wire G64   0X0086B094   2042          0.0         G1    0X00984AC2   474453         116.434     42.8
RTD3 2-wire G64   0X0084FE96   1524          0.0         G1    0X0098344B   472739         116.013     41.7
RTD4 2-wire G64   0X0086185D   1860          0.0         G1    0X0098A76D   481523         118.169     47.3
RTD5 2-wire G64   0X0089791F   2891          0.0         G1    0X0098EC49   486777         119.458     50.7
RTD6 2-wire G64   0X0084BE38   1447          0.0         G1    0X0098E7BC   486430         119.373     50.4
RTD7 2-wire G64   0X00865BC0   1940          0.0         G1    0X009851AF   474982         116.564     43.1
RTD8 2-wire G64   0X00839976   1098          0.0         G1    0X0098E777   486409         119.368     50.4
Isense = 0X00D373A6 407479[uV] 4074.79 [uA]
ErrorFlags1to4 = 0X00000000
ErrorFlags5to8 = 0X00000000

```

If any errors are active at any time on any given channel, the flags will show this where each byte in the 4 byte flag corresponds to a different channel, as per the table below for 0xAABBCCDD.

Flag Group	A	B	C	D
1 to 4	4	3	2	1
5 to 8	8	7	6	5

Any channel could have up to 5 types of errors activated where each bit in the byte means the following:

- 00000001b 0x01 Open Circuit
- 00000010b 0x02 Low Temperature Warning
- 00000100b 0x04 High Temperature Warning
- 00001000b 0x08 High Temperature Shutdown
- 00010000b 0x10 Short Circuit

```

COM4:115200baud - Tera Term VT
File Edit Setup Control Window Help
Ch   Type   Gain   RawDataLow   InputLow[uV]   Wire[Ohm]   Gain   RawDataHigh   InputHigh[uV]   Res[Ohm]   Temp[DegC]
RTD1 2-wire G64   0X00C729AC   21717         5.32964     G1    0X00FFFFFF   2499999         613.551     Open
RTD2 2-wire G64   0X0086B094   2042          0.0         G1    0X00984B15   474478         116.447     42.8
RTD3 2-wire G64   0X0084FE96   1524          0.0         G1    0X00804D8A   5916           1.45191     Short
RTD4 2-wire G64   0X0086185D   1860          0.0         G1    0X0098A722   481501         118.17       47.3
RTD5 2-wire G64   0X0089791F   2891          0.0         G1    0X00A34D11   689473         169.211     182.5
RTD6 2-wire G64   0X0084BE38   1447          0.0         G1    0X0098E767   486404         119.373     50.4
RTD7 2-wire G64   0X00865BC0   1940          0.0         G1    0X00985192   474973         116.568     43.2
RTD8 2-wire G64   0X00839976   1098          0.0         G1    0X00800706   536            0.130807     Short
Isense = 0X00D37341 407472[uV] 4074.64 [uA]
ErrorFlags1to4 = 0X00100001
ErrorFlags5to8 = 0X10000004

```

For example, in the screen capture above, Channel 1 is flagging an Open Circuit, Channels 3 and 8 are flagging a Short Circuit and Channel 5 is flagging a High Temperature Warning.

5.6. L – Load New Software

Should a software upgrade of the application software be required, the units can be reprogrammed by selecting this option. If Axiomatic has sent new software, select 'I' or 'L', and at the prompt enter the password that was provided by your Axiomatic contact.

Once the correct password has been entered (case-sensitive), the controller will automatically reset itself the bootloader header will be printed. At the prompt, hit any key (i.e. Enter) and wait for the message “**Waiting for application S-Record**” to be displayed. Go to **File/Send File** and send the AXTC20_Vx.y.z.elf.S file sent by Axiomatic.

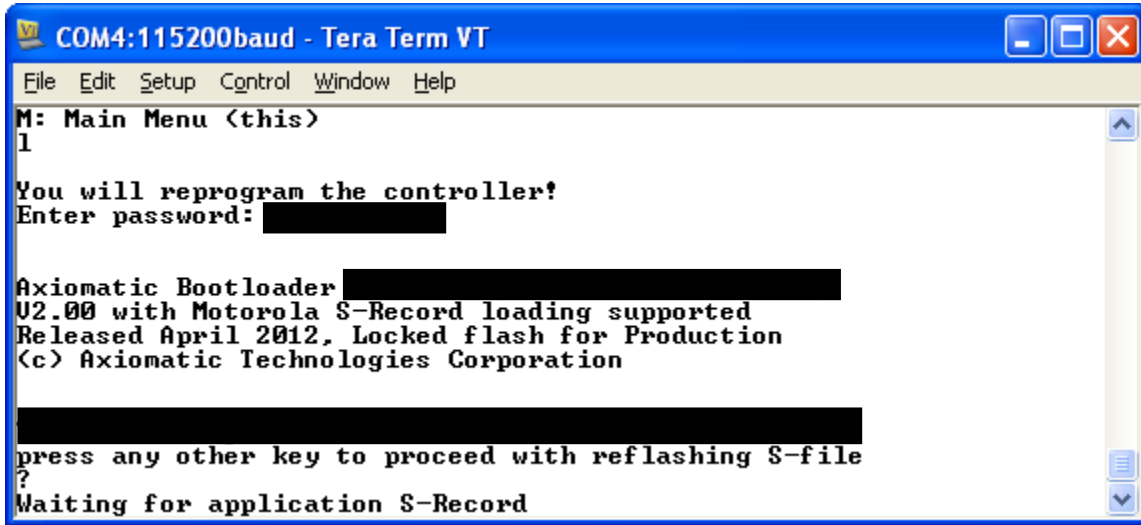

As the file uploads, a pop-up progress message will be shown, and the controller will print dots on the display. After the file has finished loading, the message “S-File has been loaded successfully” will be displayed, and the normal power-up messages will be printed. Verify the version number in the power-up banner matches that of the latest software

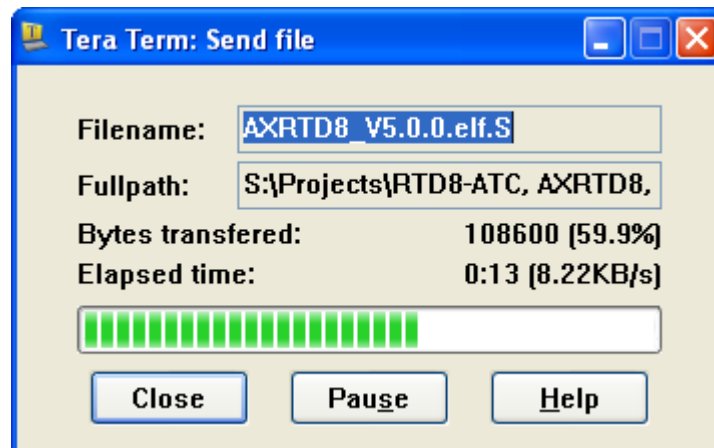

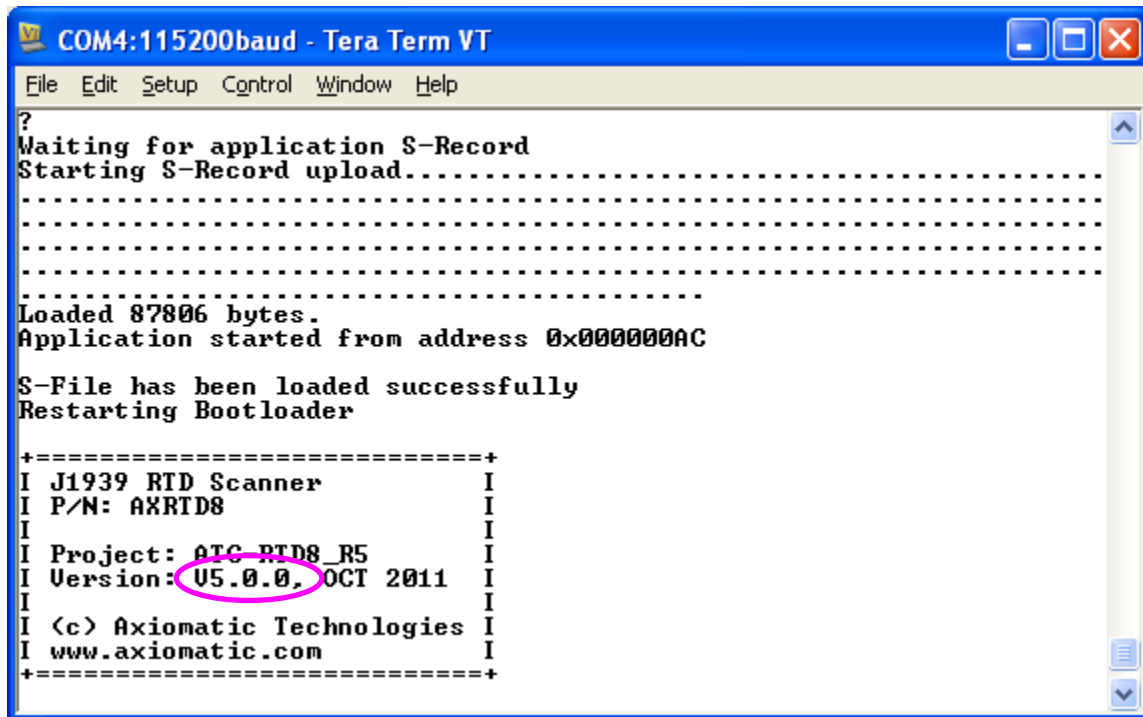

APPENDIX A – Technical Specifications

Inputs

Power Supply Input	12Vdc or 24Vdc nominal (9...32 VDC power supply range)
Supply Current	170 mA at 12 V Typical, 90 mA at 24 V Typical Inrush does not exceed 800 mA.
Protection	Reverse polarity protection is provided. Power supply input section protects against transient surges and short circuits and is isolated from RTD inputs
RTD Types	Up to 8 channels, independently configurable for 2, 3 or 4 wire RTDs. Each channel independently supports specific sensors: IEC 0.00385, JIS 0.003916, US 0.003902, Legacy 0.003920, SAMA 0.003923. A user defined coefficient would enable custom Callendar-Van Dusen constants to be set for sensors not listed above.
RTD Inputs	The device accepts inputs in the range of 10 - 350 Ohms. "Short Circuit" condition is triggered when the sensor resistance is below 5 Ohm. "Open Circuit" condition is reported when the sensor resistance exceeds approximately 600 Ohm. Accuracy: +/- 1°C typical at ambient temperature. Resolution: 0.001°C Isolation voltage is 1500 Vac (rms) or 2550V for 1 sec.
Scan Rate	100ms per channel, total sweep time maximum 900 ms
Common Mode Readings	Input range +/- 4V maximum Rejection is 100db at 5Vp-p (50-60Hz)
Thermal Drift	Overall drift with temperature is 15mOhm/°C (maximum)
Isolation	Digital isolation is 500VDC from input to ground. Three way isolation is provided for the CAN line, inputs and power supply
Averaging	The average temperature of all the active channels can be broadcasted to the network using the default "Engine Average Information" PGN, or on a Proprietary B message.
Protection	Open or short circuit detection, Frozen data detection Over or under temperature detection, High temperature shutdown detection

Communication

CAN	1 CAN 2.0Bport, protocol SAE J1939
RS-232	1 RS-232 port available, ASCII Text Format, 115200 Baud Rate Data – 8 bit, Parity – None, Stop – 1 bit. Flow Control – Xon/Xoff. Short circuit protection to ground.

General Specifications

Microprocessor	MC56F8366, 16-bit, 512 KByte flash program memory
Control Logic	User programmable functionality using Axiomatic Electronic Assistant®
User Interface	Electronic Assistant®, p/n: AX070502 Updates for the EA are found on www.axiomatic.com under the log-in tab.
UL and cUL Compliance	UL508 (April 2010) (FTPM2) – Controls for Stationary Engine Driven Assemblies cUL C22.2 No. 14-10 (2010)
CE Compliance	2004/108/EC (EMC Directive) 2011/65/EU (RoHS Directive)
Vibration	11.48 G for a device rigidly mounted to a generator housing <i>The marine type approval process tested to 4,0 G per IEC 60068-2-6, Test Fc.</i>
Marine Type Approval	Lloyd's Register, DNV, ABS, RINA, GL, BV, CCS, IRS, RS <i>The AXRTD8 meets the environmental, EMC and vibration requirements of generator set applications in marine installations.</i>
Operating Conditions	-40 to 85 °C (-40 to 185 °F)
Storage	-50 to 120 °C (-58 to 248 °F)
Humidity	Protected against 95% humidity non-condensing, 30°C to 60°C.

Enclosure	Rugged aluminum housing, stainless steel end plates, neoprene gaskets 145.30 x 149.00 x 73.00 mm (5.72 x 5.86 x 2.87") L x W x H Connectors, Deutsch IPD P/N: 1 8-pin DT13-08PA, 1 40-pin DRC13-40PA
Protection	IP67 rating, Pollution Degree 3 per UL508 <i>The marine type approval process tested to IP56.</i>
Weight	2.2 lbs. (1.00 kg)



OUR PRODUCTS

Actuator Controls
Battery Chargers
CAN bus Controls, Gateways
CAN/Wifi, CAN/Bluetooth
Current Converters
DC/DC Power Converters
DC Voltage/Current Signal Converters
Engine Temperature Scanners
Ethernet/CAN Converters
Fan Drive Controllers
Hydraulic Valve Controllers
I/O Controls
LVDT Simulators
Machine Controls
Motor Controls
PID Controls
Position Sensors, Angle Measurement Inclinometers
Power Supplies
PWM Signal Converters/Isolators
Resolver Signal Conditioners
Service Tools
Signal Conditioners
Strain Gauge CAN Controls
Surge Suppressors

OUR COMPANY

Axiomatic provides electronic machine controls, components, and systems to the off-highway, commercial vehicle, electric vehicle, power generator set, material handling, renewable energy and industrial OEM markets.

We provide efficient, innovative solutions that focus on adding value for our customers.

We emphasize service and partnership with our customers, suppliers, and employees to build long term relationships and mutual trust.

QUALITY DESIGN AND MANUFACTURING

Axiomatic is an ISO 9001:2008 registered facility.

SERVICE

All products to be returned to Axiomatic require a Return Materials Authorization Number (RMA#).

Please provide the following information when requesting an RMA number:

- Serial number, part number
- Axiomatic invoice number and date
- Hours of operation, description of problem
- Wiring set up diagram, application
- Other comments as needed

When preparing the return shipping paperwork, please note the following. The commercial invoice for customs (and packing slip) should state the harmonized international HS (tariff code), valuation and return goods terminology, as shown in italics below. The value of the units on the commercial invoice should be identical to their purchase price.

*Goods Made In Canada (or Finland)
Returned Goods for Warranty Evaluation, HS: 9813.00
Valuation Identical Goods
Axiomatic RMA#*

WARRANTY, APPLICATION APPROVALS/LIMITATIONS

Axiomatic Technologies Corporation reserves the right to make corrections, modifications, enhancements, improvements, and other changes to its products and services at any time and to discontinue any product or service without notice. Customers should obtain the latest relevant information before placing orders and should verify that such information is current and complete. Users should satisfy themselves that the product is suitable for use in the intended application. All our products carry a limited warranty against defects in material and workmanship. Please refer to our Warranty, Application Approvals/Limitations and Return Materials Process as described on www.axiomatic.com/service.html.

CONTACTS

Axiomatic Technologies Corporation
5915 Wallace Street
Mississauga, ON
CANADA L4Z 1Z8
TEL: +1 905 602 9270
FAX: +1 905 602 9279
www.axiomatic.com

Axiomatic Technologies Oy
Höytämöntie 6
33880 Lempäälä
FINLAND
TEL: +358 3 3595 600
FAX: +358 3 3595 660
www.axiomatic.fi