



USER MANUAL UMAX186001

6 CHANNEL THERMOCOUPLE SCANNER

With CANopen®

USER MANUAL

P/N: AX186001

VERSION HISTORY

Version	Date	Author	Modification
1.00	Nov. 21, 2019	Ilona Korpelainen	Initial Draft
1.00A	Nov. 29, 2019	Ilona Korpelainen	Small corrections
1.00B	Dec. 12, 2019	Ilona Korpelainen	Technical specification updated
1.00C	Mar. 19, 2020	Ilona Korpelainen	Technical specification reviewed
2.00	Jun. 17, 2020	Ilona Korpelainen	Reference to object 5010h removed (should be 2020h ADC Filter Frequency)
2.01	August 29, 2023	Kiril Mojsov	Performed Legacy Updates

ACRONYMS

AVG	Average
BATT +/-	Battery positive (a.k.a. Vps) or Battery Negative (a.k.a. GND)
CAN	Control Area Network
CANopen®	CANopen® is a registered community trademark of CAN in Automation e.V.
CAN-ID	CAN 11-bit Identifier
CJ	Cold Junction
COB	Communication Object
CTRL	Control
EDS	Electronic Data Sheet
EMCY	Emergency
FD	Fault Detection
GND	Ground reference (a.k.a. BATT-)
LSB	Least Significant Byte (or Bit)
LSS	Layer Settling Service
MSB	Most Significant Byte (or Bit)
NMT	Network Management
RO	Read Only Object
RPDO	Received Data Object
RPM	Rotations per Minute
RW	Read/Write Object
SDO	Service Data Object
TC	Thermocouple
TPDO	Transmitted Process Data Object
Vps	Voltage Power Supply (a.k.a. BATT+)
WO	Write Only Object

TABLE OF CONTENTS

1. OVERVIEW OF CONTROLLER	9
1.1. TC Input Function Blocks	9
1.2. Averaging.....	13
1.3. Cold Junction Measurements	14
1.4. Miscellaneous	15
2. INSTALLATION INSTRUCTIONS	17
2.1. Dimensions and Pinout.....	17
3. CANOPEN® OBJECT DICTIONARY	18
3.1. Node ID and Baudrate	18
3.1.1. LSS Protocol to Update	18
3.2. Communication Objects (DS-301 and DS-404)	22
3.2.1. Object 1000h: Device Type	23
3.2.2. Object 1001h: Error Register.....	23
3.2.3. Object 1002h: Manufacturer Status Register	24
3.2.4. Object 1003h: Predefined Error Field	24
3.2.5. Object 100Ch: Guard Time.....	25
3.2.6. Object 100Dh: Life Time Factor.....	26
3.2.7. Object 1010h: Store Parameters	26
3.2.8. Object 1011h: Restore Default Parameters.....	28
3.2.9. Object 1016h: Consumer Heartbeat Time.....	29
3.2.11. Object 1018h: Identity Object	30
3.2.12. Object 1020h: Verify Configuration.....	31
3.2.13. Object 1029h: Error Behavior	31
3.2.14. RPDO Behavior	32
3.2.15. TPDO Behavior.....	34
3.3. Application Objects (DS-404)	36
3.3.1. Object 6100h: TC Input Field Value	36
3.3.2. Object 6110h: TC Sensor Type	37
3.3.3. Object 6112h: TC Operating Mode.....	37
3.3.4. Object 6126h: TC Scaling Factor	38
3.3.5. Object 6127h: TC Scaling Offset.....	39
3.3.6. Object 6150h: TC Input Status	39
3.3.7. Object 7130h: TC Input Process Value	40
3.4. Manufacturer Objects	41
3.4.1. Object 2000h: CJ Auto Correct.....	41
3.4.2. Object 2010h: TC Input Microvolts	42
3.4.3. Object 2020h: ADC Filter Frequency.....	42
3.4.4. Object 2100h: AVG Input Field Value.....	43
3.4.5. Object 2112h: AVG Operating Mode.....	43
3.4.6. Object 2126h: AVG Scaling Factor.....	44

3.4.7.	Object 2127h: AVG Scaling Offset	45
3.4.8.	Object 2130h: AVG Input Process Value	45
3.4.9.	Object 3100h: CJ Input Field Value	46
3.4.10.	Object 3126h: CJ Scaling Factor	46
3.4.11.	Object 3127h: CJ Scaling Offset	46
3.4.12.	Object 3130h: CJ Input Process Value	47
3.4.13.	Object 4000h: TC Low Temperature Warning Threshold	47
3.4.14.	Object 4010h: TC High Temperature Warning Threshold	48
3.4.15.	Object 4020h: TC High Temperature Shutdown Threshold	48
3.4.16.	Object 4030h: TC Error React Delay	49
3.4.17.	Object 5040h: FD Field Value	50
3.4.18.	Object 5041h: FD Set Threshold	50
3.4.19.	Object 5042h: FD Clear Threshold	51
3.4.20.	Object 5050h: FD Enable Fault Detection	52
3.4.21.	Object 5051h: FD Error Response Delay	53
3.4.22.	Object 5555h: Start in Operational Mode	53
3.4.23.	Object 5556h: Start in Operational NMT Delay	54
APPENDIX A - TECHNICAL SPECIFICATION.....		A-1

Table 1 – Object 6110hTC Sensor Type Options 11
Table 2 – Object 2112h Average Operating Mode Options 13
Table 3 – Object 5555h Start in Operational Options..... 16
Table 4 – LSS Baudrate Indices 20
Table 5 – EMCY Error Codes 25
Table 6 – Error Descriptions 25
Table 7 – Thermocouple Status Values 40

Figure 1 - AX186001 Block Diagram 9
Figure 2 – Thermocouple Input Function Block diagram..... 10
Figure 3 – Averaging Function Block Diagram 13
Figure 4 – Cold Junction Function Block Diagram 14
Figure 5 – Miscellaneous Objects Block Diagram 15
Figure 6 – AX186001 Dimensional Drawing 17

REFERENCES

- [DS-301] CiA DS-301 V4.1 – CANopen® Application Layer and Communication Profile. CAN in Automation 2005
- [DS-305] CiA DS-305 V2.0 – Layer Setting Service (LSS) and Protocols. CAN in Automation 2006
- [DS-404] CiA DS-404 V1.2 – CANopen® profile for Measurement Devices and Closed Loop Controllers. CAN in Automation 2002

These documents are available from the CAN in Automation e.V. website at: <http://www.can-cia.org/>.

1. OVERVIEW OF CONTROLLER

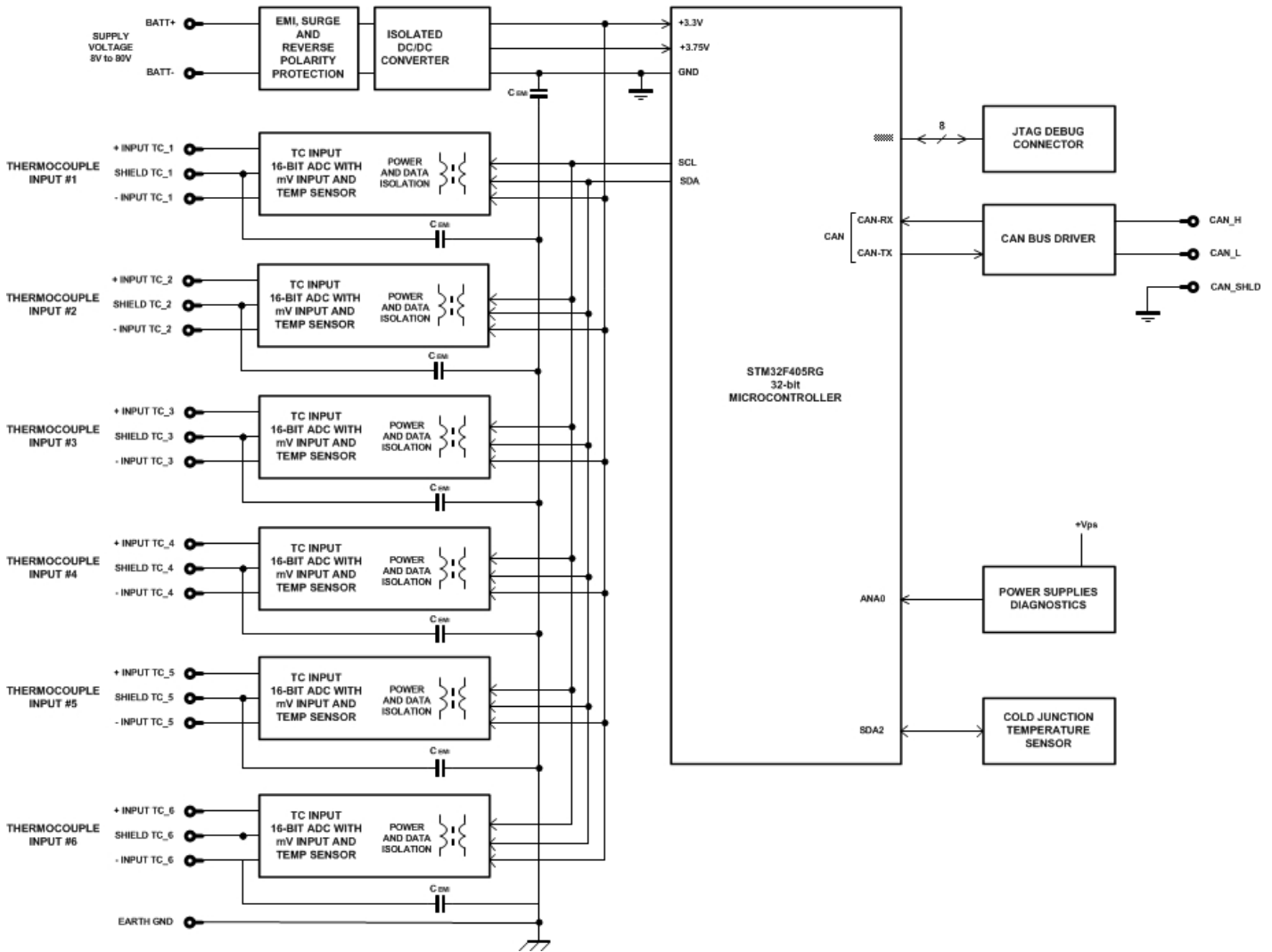

Figure 1 - AX186001 Block Diagram

The 6 Channel Thermocouple Scanner (TC6-ST-CO) monitors up to 6 thermocouple channels and provides the temperature information over a CANopen® CAN bus. The channels are independently configurable as Type J, K, B, E, N, R, S or T thermocouples.

The controller is widely configurable through CANopen® Objects. All objects are user-configurable using standard commercially available tools that can interact with a CANopen® Object Dictionary via an .EDS file.

Functional blocks of the controller are presented in next subchapters.

1.1. TC Input Function Blocks

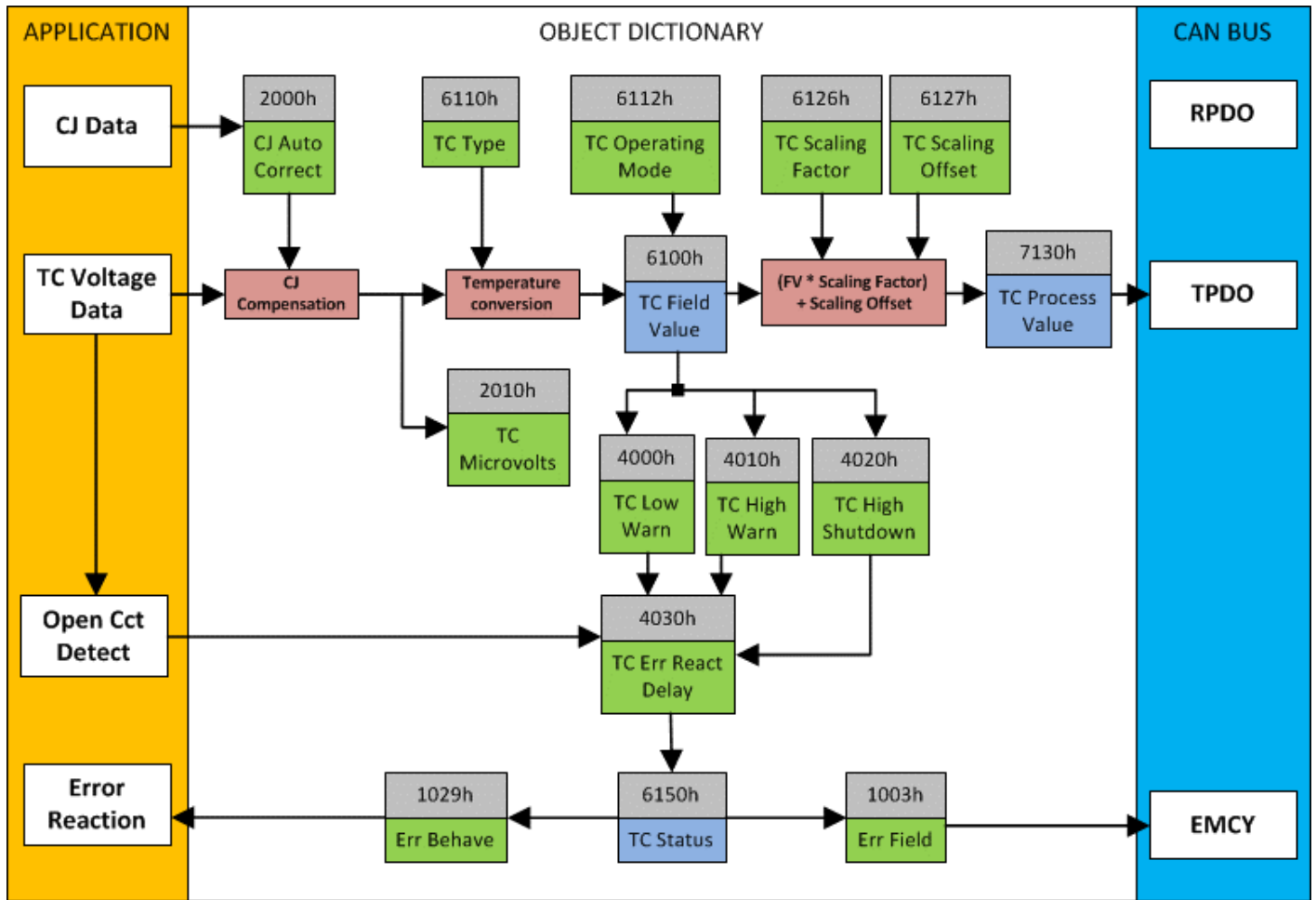

Figure 2 – Thermocouple Input Function Block diagram

The 6 Channel Thermocouple Scanner has six thermocouple inputs, each provided with three pins in the connector (see section 2.1) for +ve, -ve and shield connections. Thermocouple voltages are measured with six 16-bit Σ - Δ analog-to-digital (ADC) converters. The ADC gain is adjusted for best resolution and accuracy. The thermocouple channels are read every 165ms. However, rapid changes, for example from 0V to Open Circuit, may take up to 1500ms to process due to adjusting the ADC gain.

The ADC has programmable rejection mode for either 50Hz or 60Hz, which provides minimum of 110dB normal mode rejection on the line frequency and its harmonics. Rejection filter frequency is selected with object 2020h **ADC Filter Frequency**.

A high accuracy digital temperature sensor is placed next to thermocouple connectors to provide cold junction compensation. By default, all temperatures are compensated for the cold junction temperature, but it is possible to choose not to use cold junction compensation, by setting object 2000h **CJ Auto Correct** setpoint to 'False'. Cold Junction measurements are further presented in section 1.3.

The scanner supports eight common types of thermocouples. Thermocouple type is selected with object 6110h **TC Sensor Type**. Value options for the object are presented in Table 1.

1	<i>J Type</i>
2	<i>K Type</i>
4	<i>N Type</i>
5	<i>R Type</i>
6	<i>S Type</i>
7	<i>T Type</i>
9	<i>E Type</i>
10	<i>B Type</i>

Table 1 – Object 6110hTC Sensor Type Options

Object 6112h **TC Operating Mode** enables thermocouple channel microvolt conversion into Celsius degree temperature value. Temperature value is written to read-only object 6100h **TC Input Field Value**. Measured millivolt value (including cold junction compensation, if enabled) is written to read-only object 2010h **TC Microvolts**. If a thermocouple channel is disabled, value 0xFFC00000 is written into the field value object and 0xFFFF (-1) is written into the process value object.

Objects 6126h **TC Scaling Factor** and 6127h **TC Scaling Offset** are used to convert the field value to TPDO mappable read-only object 7130h **TC Input Process Value**. By default, all six thermocouple channels are enabled for J-type conversion and mapped into TPDO1 and TPDO2.

The formula to convert the field value (FV) to process value (PV) is:

$$\text{Process Value} = (\text{Field Value} * \text{Scaling Factor}) + \text{Scaling Offset}$$

While FV is 32-bit Floating point value, which presents measured temperature in °C, the PV is 16-bit integer value. By default, FV is scaled with Scaling factor of 16 and Offset 4368, to produce PV value with 0.0625 °C/bit resolution and -273 °C offset. Thus, PV data can present whole nominal temperature range (-273 °C to 1735 °C).

If desired, PV can be scaled for example to present temperature in Fahrenheit with 0.1 °F/bit resolution by setting the Scaling Factor to 18 and the Offset to 320.

The PV also reflects state of the thermocouple. When thermocouple is disabled with object 6112h PV value is -1 (0xFFFF) regardless of the selected scaling. In case, the scanner detects an open circuit on the sensor the PV value is set to -512 (0xFE00) to reflect error condition.

In addition to open circuit condition the thermocouple scanner can detect and flag three other thermocouple related error conditions, High Temperature Shutdown, High Temperature Warning and Low Temperature Warning. Error detection thresholds are selected with objects 4000h **TC Low Temperature Warning Threshold**, 4010h **TC High Temperature Threshold**, 4020h **TC High Temperature Threshold**. The threshold values have fixed resolution of 0.1 °C/bit and a fixed 1 °C built-in hysteresis is utilized for error clearing threshold.

In order to prevent the network with emergency messages, the object 4030h **TC Error React Delay** allows the user to select how long the fault condition must be present before error reaction is triggered.

Once error reaction is triggered EMCY message is sent and the object 1003h **Pre-Defined Error Field** is updated to reflect the appropriate EMCY error code and additional information. In addition, value of the object 6150h **TC Status** is updated to reflect the error condition. If desired, the controller can be configured to react to an error by changing operation mode with propriate object 1029h **Error Behavior value**.

1.2. Averaging

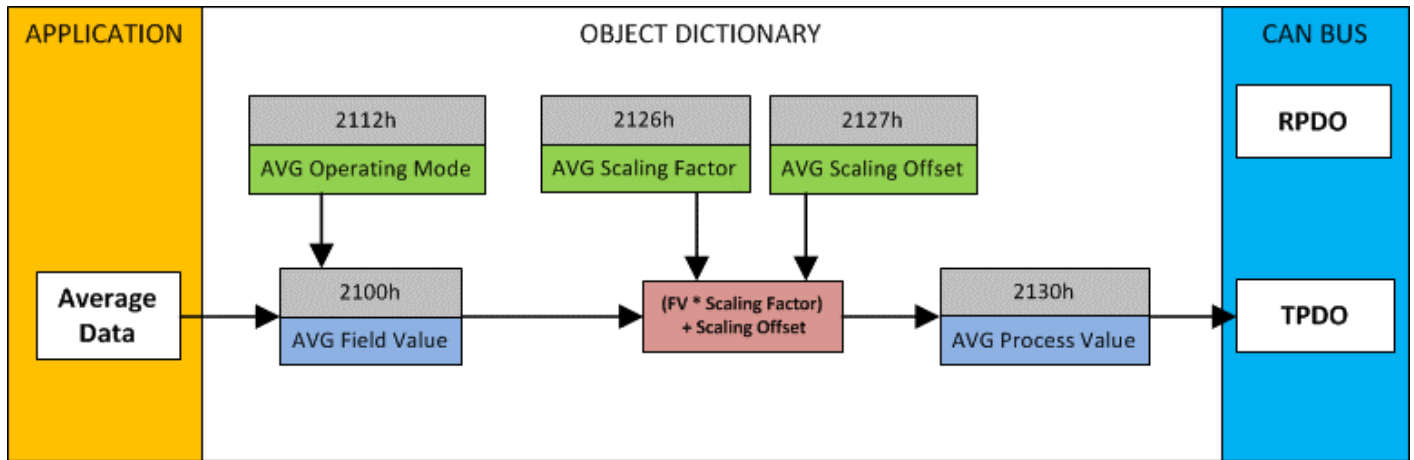

Figure 3 – Averaging Function Block Diagram

Averaging block calculates average temperature of the selected Thermocouple channels that can be mapped to a TPDO. Averaging 1 produces average temperature of thermocouple channels 1 to 3 and Averaging 2 produces average temperature of Thermocouple channels 4 to 6 and Averaging 6 produces average temperature of all six Thermocouple channels.

Object 2112h **AVG Operating Mode** if averaging is enabled. When Averaging Mode is set to normal operation, the average of all active channels is calculated and written to read-only object 2100h **AVG Input Field Value** in °C. If a thermocouple channel is disable or an open circuit is detected the thermocouple channel value is omitted form the average calculation.

0	<i>Disabled</i>
1	<i>Normal Operation</i>

Table 2 – Object 2112h Average Operating Mode Options

Average FV is converted to PV with objects 2126h **AVG Scaling Factor** and 2127h **AVG Scaling Offset** using same formula as with thermocouple values described in section 1.1. PV is written to read only object 2130h **AVG Input Process Value**.

By default, averages are enabled and mapped into TPDO3.

1.3. Cold Junction Measurements

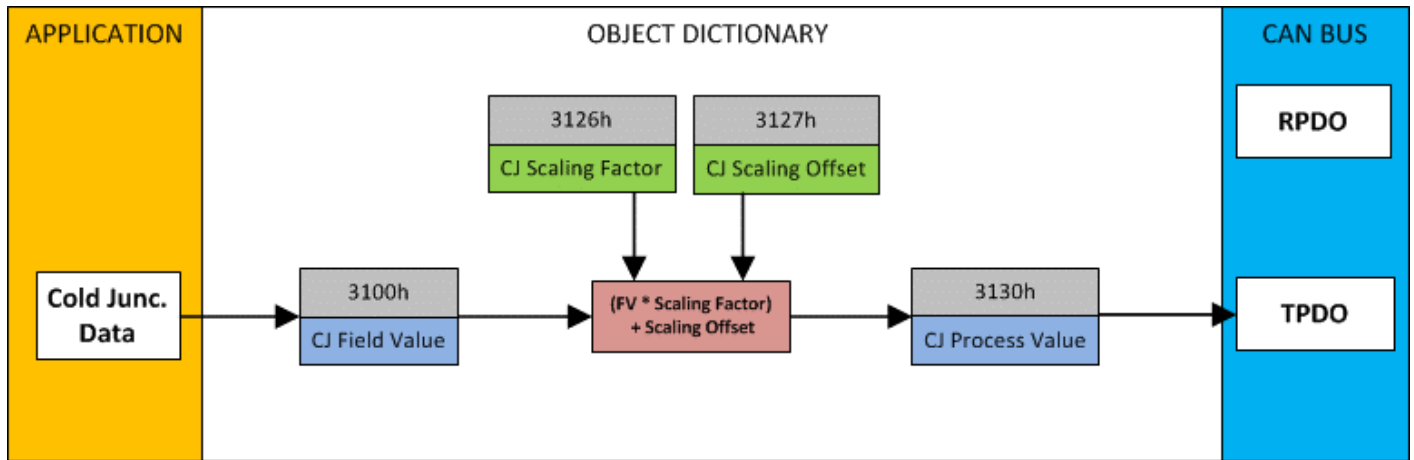

Figure 4 – Cold Junction Function Block Diagram

The cold junction temperature is measured with an on-board temperature sensor. A high accuracy digital temperature sensor is placed next to thermocouple connectors to provide temperature value for cold junction compensation.

The measured cold junction temperature is written to read-only object 3100h **Cold Junction Input Field Value**. The FV is converted to PV with objects 3126h **CJ Scaling Factor** and 3127h **CJ Scaling Offset** using same formula as with thermocouples described in section 1.1. The PV is written to TPDO mappable read-only object 3130h **CJ Input Process Value**. By default, CJ Input process Value is broadcasted on TPDO3.

1.4. Miscellaneous

There are some other objects available, which have not yet been discussed or mentioned briefly in passing. These objects are not necessarily associated with one another but are all discussed here.

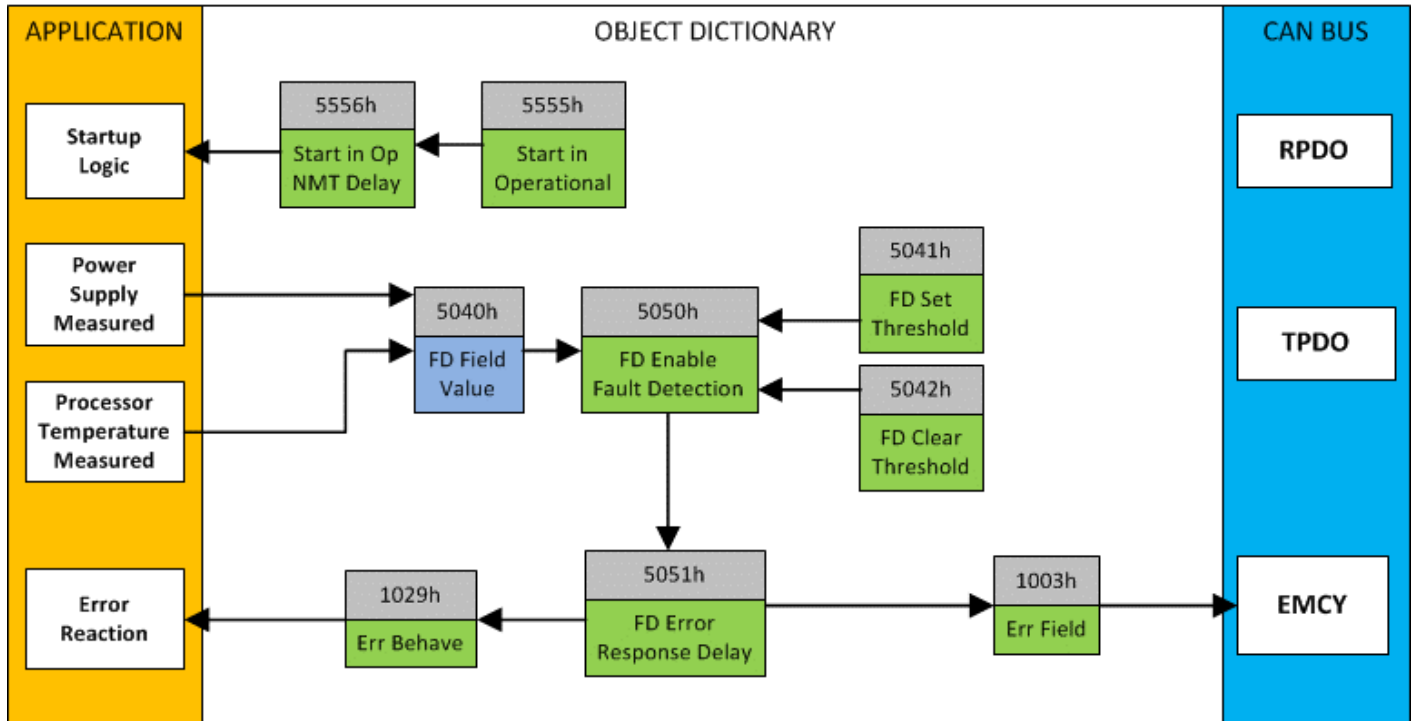

Figure 5 – Miscellaneous Objects Block Diagram

Fault Detection Objects

In addition to fault detection associated with thermocouples there is fault detection available for TC6-ST-CO power supply voltage and CPU temperature. Object 5040h **FD Field Value** sub1 contains measured CPU Temperature in 0.1°C and 5040h **FD Field Value** sub2 contains measured power supply voltage in 0.1 Volts. These values are only directional and are suitable only for monitoring that measured quantities stay roughly in range of normal operation.

Object 5041h **FD Set Threshold** sets the limit that value is compared against. 5041h sub1 contains temperature high limit in 0.1°C, fault is flagged when CPU temperature increases above this limit. 5041h sub2 contains Power supply high limit and sub3 contains power supply low limit in Volts. Respectively, object 5042h **FD Clear Threshold** sets the limits that value is compared against to clear the fault.

Object 5051h **FD Error Response Delay** will determine how long the fault needs to be present to trigger error reaction. Object 5050h **FD Enable Fault Detection** is used to enable or disable CPU temperature and power supply voltage fault detection.

Startup

The object 5555h **Start in Operational** is provided as a 'cheat' when the unit is not intended to work with a CANopen® network (i.e. a stand-alone control), or is working on a network comprised solely as slaves so the OPERATION command will never be received from a master. By default, this object is disabled.

0	<i>Disabled</i>
1	<i>Start in operational mode</i>
2	<i>Start in operational mode and send an NMT for starting other devices on the bus.</i>

Table 3 – Object 5555h Start in Operational Options

When using the TC6-ST-CO as a stand-alone controller where 5555h is set to TRUE, it is recommended to disable all TPDOs (set the Event Timer to zero) so that it does not run with a continuous CAN error when not connected to a bus.

In case the TC6-ST-CO is set to start in operational and to send operational NMT message, the delay between startup and NMT message can be adjusted with object 5556h **Start In Operational NMT Delay**.

2. INSTALLATION INSTRUCTIONS

2.1. Dimensions and Pinout

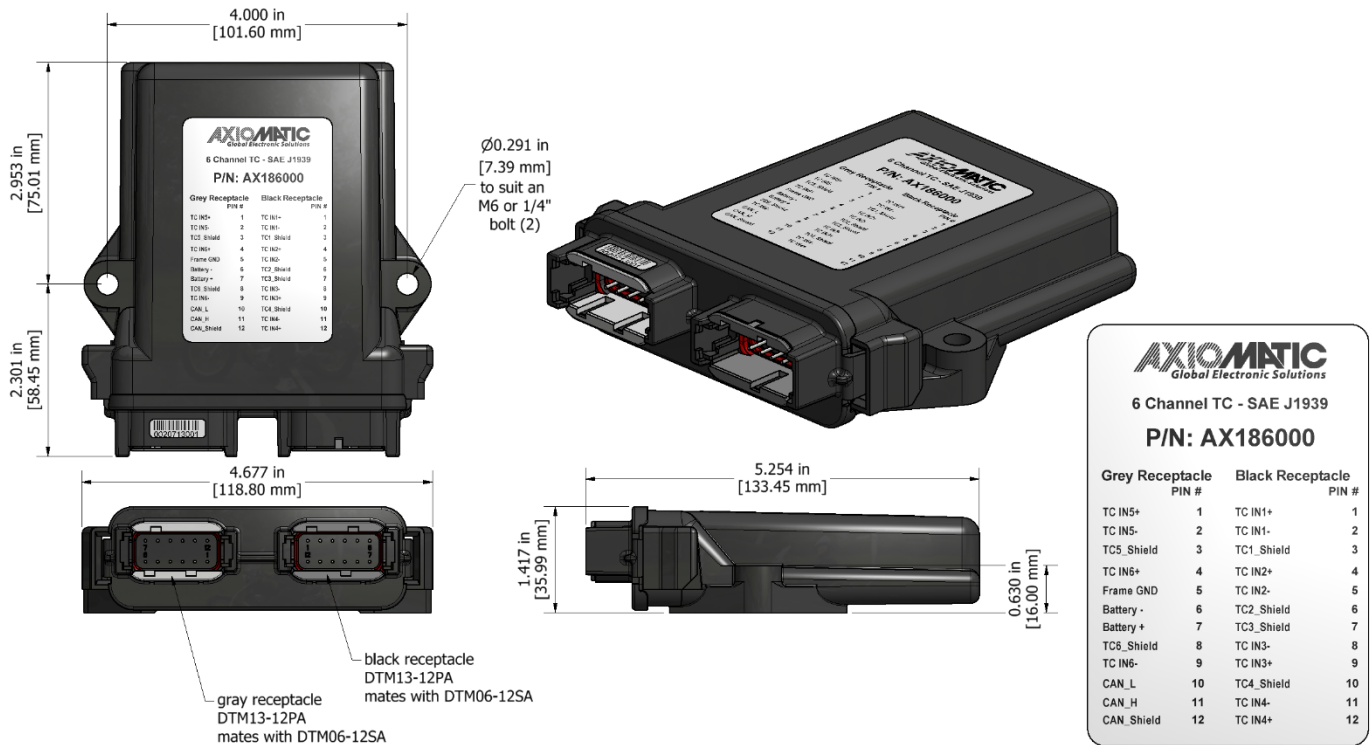

Figure 6 – AX186001 Dimensional Drawing

3. CANOPEN® OBJECT DICTIONARY

The CANopen® object dictionary of the TC6-ST-CO Controller is based on CiA device profile DS-404 V1.2 (Measurement Devices and Closed Loop Controllers). The object dictionary includes Communication Objects beyond the minimum requirements in the profile, as well as several manufacturer-specific objects for extended functionality.

3.1. Node ID and Baudrate

By default, the TC6-ST-CO Controller ships factory programmed with a Node ID = 127 (0x7F) and with Baudrate = 125 kbps

3.1.1. LSS Protocol to Update

The only means by which the Node-ID and Baudrate can be changed is to use Layer Settling Services (LSS) and protocols as defined by CANopen® standard DS-305.

Follow the steps below to configure either variable using LSS protocol. If required, please refer to the standard for more detailed information about how to use the protocol

3.1.1.1. Setting Node-ID

- Set the module state to LSS-configuration by **sending** the following message:

<i>Item</i>	<i>Value</i>
COB-ID	0x7E5
Length	2
Data 0	0x04 (cs=4 for switch state global)
Data 1	0x01 (switches to configuration state)

- Set the Node-ID by **sending** the following message:

<i>Item</i>	<i>Value</i>
COB-ID	0x7E5
Length	2
Data 0	0x11 (cs=17 for configure node-id)
Data 1	Node-ID (set new Node-ID as a hexadecimal number)

- The module will send the following response (any other response is a failure).

<i>Item</i>	<i>Value</i>
COB-ID	0x7E4
Length	3
Data 0	0x11 (cs=17 for configure node-id)
Data 1	0x00

Data 2	0x00
--------	------

- Save the configuration by **sending** the following message:

<i>Item</i>	<i>Value</i>
COB-ID	0x7E5
Length	1
Data 0	0x17 (cs=23 for store configuration)

- The module will send the following response (any other response is a failure)

<i>Item</i>	<i>Value</i>
COB-ID	0x7E4
Length	3
Data 0	0x17 (cs=23 for store configuration)
Data 1	0x00
Data 2	0x00

- Set the module state to LSS-operation by **sending** the following message: (Note, the module will reset itself back to the pre-operational state)

<i>Item</i>	<i>Value</i>
COB-ID	0x7E5
Length	2
Data 0	0x04 (cs=4 for switch state global)
Data 1	0x00 (switches to waiting state)

3.1.1.2. Setting Baudrate

- Set the module state to LSS-configuration by sending the following message:

<i>Item</i>	<i>Value</i>
COB-ID	0x7E5
Length	2
Data 0	0x04 (cs=4 for switch state global)
Data 1	0x01 (switches to configuration state)

- Set the baudrate by sending the following message:

<i>Item</i>	<i>Value</i>
COB-ID	0x7E5
Length	3
Data 0	0x13 (cs=19 for configure bit timing parameters)
Data 1	0x00 (switches to waiting state)
Data 2	Index (select baudrate index per Table 32)

Index	Bit Rate
0	1 Mbit/s
1	800 kbit/s
2	500 kbit/s
3	250 kbit/s
4	125 kbit/s (default)
5	reserved (100 kbit/s)
6	50 kbit/s
7	20 kbit/s
8	10 kbit/s

Table 4 – LSS Baudrate Indices

- The module will send the following response (any other response is a failure):

Item	Value
COB-ID	0x7E4
Length	3
Data 0	0x13 (cs=19 for configure bit timing parameters)
Data 1	0x00
Data 2	0x00

- Activate bit timing parameters by sending the following message:

Item	Value
COB-ID	0x7E5
Length	3
Data 0	0x15 (cs=19 for activate bit timing parameters)
Data 1	<delay_lsb>
Data 2	<delay_msb>

The delay individually defines the duration of the two periods of time to wait until the bit timing parameters switch is done (first period) and before transmitting any CAN message with the new bit timing parameters after performing the switch (second period). The time unit of switch delay is 1 ms.

- Save the configuration by sending the following message (on the NEW baudrate):

Item	Value
COB-ID	0x7E5
Length	1
Data 0	0x17 (cs=23 for store configuration)

- The module will send the following response (any other response is a failure):

Item	Value
COB-ID	0x7E4
Length	3
Data 0	0x17 (cs=23 for store configuration)

Data 1	0x00
Data 2	0x00

- Set the module state to LSS-operation by sending the following message: (Note, the module will reset itself back to the pre-operational state)

Item	Value
COB-ID	0x7E5
Length	2
Data 0	0x04 (cs=4 for switch state global)
Data 1	0x00 (switches to waiting state)

The following screen capture (left) shows the CAN data was sent (7E5h) and received (7E4h) by the tool when the baudrate was changed to 250 kbps using the LSS protocol. The other image (right) shows what was printed on an example debug RS-232 menu while the operation took place.

Between CAN Frame 98 and 99, the baudrate on the CAN Scope tool was changed from 125 to 250 kbps.

The left screenshot shows the Net0 CAN USB331 250 - CANscope interface. It features a menu bar (File, Can, Help), an 'Add/Delete ID Area' section with 'from' and 'to' fields, an 'Add >' button, a '< Del' button, and a 'Net:' dropdown set to '0 - CAN_USB331'. Below this is a table of CAN frames with columns: Fram..., Absolute Time, RelTime, Id, Atr, L, d1, d2, d3, d4. The table contains frames 95 through 102. Frame 102 is highlighted in blue. At the bottom, there are 'Send' and 'ID:' fields, checkboxes for '29-Bit' and 'RTR', and 'Len:' and 'Data\$:' fields. The status bar shows 'Fill: 102(10.2%)', 'Bus: ok', and 'STARTED'.

The right screenshot shows a terminal window with a menu bar (File, Edit, Setup, Control, Window, Help). The terminal output is as follows:

```

===== Main Menu =====
Choose one of the following:
U: View Object Dictionary
D: Default Object Dictionary
T: Toggle RS-232 Stream On/Off
S: Show/Stop Diagnostics
L: Load New Software
M: Main Menu <this>

->Node Id = 80
->Baudrate= 125 [kbps]
CO: PRE-OPERATIONAL
Activating new baud = 250 [kbps]
CO: STOP
Restarting CAN in 5000 [ms]
CO: PRE-OPERATIONAL
Storing ID
Storing Factory Parameters

Storing Baud
Storing Factory Parameters

Storing Communication Parameters

->Node Id = 80
->Baudrate= 250 [kbps]
CO: PRE-OPERATIONAL

```

3.2. Communication Objects (DS-301 and DS-404)

<i>Index (hex)</i>	<i>Object</i>	<i>Object Type</i>	<i>Data Type</i>	<i>Access</i>	<i>PDO Mapping</i>
1000	Device Type	VAR	UNSIGNED32	RO	No
1001	Error Register	VAR	UNSIGNED8	RO	No
1002	Manufacturer Status Register	VAR	UNSIGNED32	RO	No
1003	Pre-Defined Error Field	ARRAY	UNSIGNED32	RO	No
100C	Guard Time	VAR	UNSIGNED16	RW	No
100D	Life Time Factor	VAR	UNSIGNED8	RW	No
1010	Store Parameters	ARRAY	UNSIGNED32	RW	No
1011	Restore Default Parameters	ARRAY	UNSIGNED32	RW	No
1016	Consumer Heartbeat Time	ARRAY	UNSIGNED32	RW	No
1017	Producer Heartbeat Time	VAR	UNSIGNED16	RW	No
1018	Identity Object	RECORD		RO	No
1020	Verify Configuration	ARRAY	UNSIGNED32	RO	No
1029	Error Behavior	ARRAY	UNSIGNED8	RW	No
1400	RPDO1 Communication Parameter	RECORD		RW	No
1401	RPDO2 Communication Parameter	RECORD		RW	No
1402	RPDO3 Communication Parameter	RECORD		RW	No
1403	RPDO4 Communication Parameter	RECORD		RW	No
1600	RPDO1 Mapping Parameter	RECORD		RO	No
1601	RPDO2 Mapping Parameter	RECORD		RO	No
1602	RPDO3 Mapping Parameter	RECORD		RO	No
1603	RPDO4 Mapping Parameter	RECORD		RO	No
1800	TPDO1 Communication Parameter	RECORD		RW	No
1801	TPDO2 Communication Parameter	RECORD		RW	No
1802	TPDO3 Communication Parameter	RECORD		RW	No
1803	TPDO4 Communication Parameter	RECORD		RW	No
1A00	TPDO1 Mapping Parameter	RECORD		RW	No
1A01	TPDO2 Mapping Parameter	RECORD		RW	No
1A02	TPDO3 Mapping Parameter	RECORD		RW	No
1A03	TPDO4 Mapping Parameter	RECORD		RW	No

3.2.1. Object 1000h: Device Type

This object contains information about the device type as per device profile DS-404. The 32-bit parameter is divided into two 16-bit values, showing General and Additional information as shown below.

MSB	LSB
Additional Information = 0x0002	General Information = 0x0194 (404)

DS-404 defines the Additional Information field in the following manner:

- 0000h = reserved
- 0001h = digital input block
- 0002h = analog input block
- 0004h = digital output block
- 0008h = analog output block
- 0010h = controller block (aka PID)
- 0020h = alarm block
- 0040h ... 0800h = reserved
- 1000h = reserved
- 2000h = lookup table block (manufacturer-specific)
- 4000h = programmable logic block (manufacturer-specific)
- 8000h = miscellaneous block (manufacturer-specific)

Object Description

Index	1000h
Name	Device Type
Object Type	VAR
Data Type	UNSIGNED32

Entry Description

Access	RO
PDO Mapping	No
Value Range	0x00020194
Default Value	0x00020194

3.2.2. Object 1001h: Error Register

This object is an error register for the device. Any time there is an error detected by the TC6-ST-CO Controller, the Generic Error Bit (bit 0) is set. Only if there are no errors in the module will this bit will be cleared. No other bits in this register are used by the TC6-ST-CO Controller.

Object Description

Index	1001h
Name	Error Register
Object Type	VAR
Data Type	UNSIGNED8

Entry Description

Access	RO
PDO Mapping	No

Value Range	00h or 01h
Default Value	0

3.2.3. Object 1002h: Manufacturer Status Register

This object is used for manufacturer debug purposes.

3.2.4. Object 1003h: Predefined Error Field

This object provides an error history by listing the errors in the order that they have occurred. An error is added to the top of the list, when it occurs, and is immediately removed when the error condition has been cleared. The latest error is always at sub-index 1, with sub-index 0 containing the number of errors currently in the list. When the device is in an error-free state, the value of sub-index 0 is zero.

The error list may be cleared by writing a zero to sub-index 0, which will clear all errors from the list, regardless of whether they are still present. Clearing the list does NOT mean that the module will return to the error-free behavior state if at least one error is still active.

The TC6-ST-CO Controller has a limitation of a maximum of 9 errors in the list. If the device registers more errors, the list will be truncated, and the oldest entries will be lost.

The error codes stored in the list are 32-bit unsigned numbers, consisting of two 16-bit fields. The lower 16-bit field is the EMCY error code, and the higher 16-bit field is a manufacturer-specific code. The manufacturer-specific code is divided into two 8-bit fields, with the higher byte indicating the error description, and the lower byte indicating the channel on which the error occurred.

MSB	LSB	
Error Description	Channel-ID	EMCY Error Code

When a sensor fault is detected, the corresponding Channel-ID will be 0x01 for Thermocouple 1, 0x02 for Thermocouple 2, 0x03 for Thermocouple 3, 0x04 for Thermocouple 4, 0x05 for Thermocouple 5, 0x06 for Thermocouple 6.

If node-guarding is used (not recommended per the latest standard) and a lifeguard event occurs, the manufacturer-specific field will be set to 0x1000. On the other hand, if a heartbeat consumer fails to be received within the expected timeframe, the Error Description will be set to 0x80 and the Channel-ID (nn) will reflect the Node-ID of the consumer channel that was not producing. In this case, the manufacturer-specific field will therefore be 0x80nn. In both cases, the corresponding EMCY Error Code will be the Guard Error 0x8130.

If an RPDO is not received within the expected “Event Timer” period, an RPDO timeout will be flagged. Used EMCY Error Codes and their meanings are presented in Table 5. Manufacturer-specific Error Descriptions are listed in Table 6.

Code	Meaning
0x000	<i>Error Reset (No Errors)</i>

0x8100	<i>Communication Generic</i>
0x8110	<i>CAN Overrun</i>
0x8130	<i>Life Guard / Heartbeat error</i>
0x8400	<i>Buss Off Recovery</i>
0xF001	<i>Input Overload – Thermocouple Open Circuit</i>
0xF011	<i>Limit Exceeded – See Table 6</i>
0x3100	<i>Device Voltage</i>
0x4200	<i>Device Temperature</i>

Table 5 – EMCY Error Codes

Code	Meaning
0x00	<i>No specific description</i>
0x10	<i>Positive Overload Warning</i>
0x20	<i>Negative Overload Warning</i>
0x40	<i>Positive Overload Shutdown</i>

Table 6 – Error Descriptions

Object Description

Index	1003h
Name	Pre-Defined Error Field
Object Type	ARRAY
Data Type	UNSIGNED32

Entry Description

Sub-Index	0h
Description	Number of entries
Access	RW
PDO Mapping	No
Value Range	0 to 9
Default Value	0

Sub-Index	1h to 9
Description	Standard error field
Access	RO
PDO Mapping	No
Value Range	UNSIGNED32
Default Value	0

3.2.5. Object 100Ch: Guard Time

The objects at index 100Ch and 100Dh shall indicate the configured guard time respective to the life time factor. The life time factor multiplied with the guard time gives the life time for the life guarding protocol described in DS-301. The Guard Time value shall be given in multiples of ms, and a value of 0000h shall disable the life guarding.

It should be noted that this object, and that of 100Dh are only supported for backwards compatibility. The standard recommends that newer networks do not use the life guarding protocol, but rather heartbeat monitoring instead. Both life guarding and heartbeats can NOT be active simultaneously.

Object Description

Index	100Ch
Name	Guard Time
Object Type	VAR
Data Type	UNSIGNED16

Entry Description

Sub-Index	0h
Access	RW
PDO Mapping	No
Value Range	0 to 65535
Default Value	0

3.2.6. Object 100Dh: Life Time Factor

The life time factor multiplied with the guard time gives the life time for the life guarding protocol. A value of 00h shall disable life guarding.

Object Description

Index	100Dh
Name	Life time factor
Object Type	VAR
Data Type	UNSIGNED8

Entry Description

Sub-Index	0h
Access	RW
PDO Mapping	No
Value Range	0 to 255
Default Value	0

3.2.7. Object 1010h: Store Parameters

This object supports the saving of parameters in non-volatile memory. In order to avoid storage of parameters by mistake, storage is only executed when a specific signature is written to the appropriate sub-index. The signature is "save".

The signature is a 32-bit unsigned number, composed of the ASCII codes of the signature characters, according to the following table:

MSB		LSB	
e	v	a	s
65h	76h	61h	73h

On reception of the correct signature to an appropriate sub-index, the TC6-ST-CO Controller will store the parameters in non-volatile memory, and then confirm the SDO transmission.

By read access, the object provides information about the module's saving capabilities. For all sub-indexes, this value is 1h, indicating that the TC6-ST-CO Controller saves parameters on command. **This means that if power is removed before the Store object is written, changes to the Object Dictionary will NOT have been saved in the non-volatile memory and will be lost on the next power cycle.**

Object Description

Index	1010h
Name	Store Parameters
Object Type	ARRAY
Data Type	UNSIGNED32

Entry Description

Sub-Index	0h
Description	Largest sub-index supported
Access	RO
PDO Mapping	No
Value Range	8
Default Value	8

Sub-Index	1h
Description	Save all parameters
Access	RW
PDO Mapping	No
Value Range	0x65766173 (write access) 1h (read access)
Default Value	1h

Sub-Index	2h
Description	Save communication parameters
Access	RW
PDO Mapping	No
Value Range	0x65766173 (write access) 1h (read access)
Default Value	1h

Sub-Index	3h
Description	Save application parameters
Access	RW
PDO Mapping	No
Value Range	0x65766173 (write access) 1h (read access)
Default Value	1h

Sub-Index	4h
Description	Save manufacturer parameters
Access	RW
PDO Mapping	No
Value Range	0x65766173 (write access)

	1h (read access)
Default Value	1h

3.2.8. Object 1011h: Restore Default Parameters

This object supports the restoring of the default values for the object dictionary in non-volatile memory. In order to avoid restoring of parameters by mistake, the device restores the defaults only when a specific signature is written to the appropriate sub-index. The signature is “load”.

The signature is a 32-bit unsigned number, composed of the ASCII codes of the signature characters, according to the following table:

MSB		LSB	
d	a	o	l
64h	61h	6Fh	6Ch

On reception of the correct signature to an appropriate sub-index, the TC6-ST-CO Controller will restore the defaults in non-volatile memory, and then confirm the SDO transmission. **The default values are set valid only after the device is reset or power cycled.** This means that the TC6-ST-CO Controller will NOT start using the default values right away, but rather continue to run from whatever values were in the Object Dictionary prior to the restore operation.

By read access, the object provides information about the module’s default parameter restoring capabilities. For all sub-indexes, this value is 1h, indicating that the TC6-ST-CO Controller restores defaults on command.

Object Description

Index	1011h
Name	Restore Default Parameters
Object Type	ARRAY
Data Type	UNSIGNED32

Entry Description

Sub-Index	0h
Description	Largest sub-index supported
Access	RO
PDO Mapping	No
Value Range	4
Default Value	4

Sub-Index	1h
Description	Restore all default parameters
Access	RW
PDO Mapping	No
Value Range	0x64616F6C (write access), 1h (read access)
Default Value	1h

Sub-Index	2h
Description	Restore default communication parameters
Access	RW
PDO Mapping	No
Value Range	0x64616F6C (write access), 1h (read access)

Default Value	1h
---------------	----

Sub-Index	3h
Description	Restore default application parameters
Access	RW
PDO Mapping	No
Value Range	0x64616F6C (write access), 1h (read access)
Default Value	1h

Sub-Index	4h
Description	Restore default manufacturer parameters
Access	RW
PDO Mapping	No
Value Range	0x64616F6C (write access), 1h (read access)
Default Value	1h

3.2.9. Object 1016h: Consumer Heartbeat Time

The TC6-ST-CO Controller can be a consumer of heartbeat objects for a single module. This object defines the expected heartbeat cycle time for that module, and if set to zero, it is not used. When the object is non-zero, the time is a multiple of 1ms, and monitoring will start after the reception of the first heartbeat from the module. If the TC6-ST-CO Controller fails to receive a heartbeat from a node in the expected timeframe, it will indicate a communication error, and respond as per object 1029h.

Bits	31-24	23-16	15-0
Value	Reserved 00h	Node-ID	Heartbeat time
Encoded as		UNSIGNED8	UNSIGNED16

Object Description

Index	1016h
Name	Consumer heartbeat time
Object Type	ARRAY
Data Type	UNSIGNED32

Entry Description

Sub-Index	0h
Description	Number of entries
Access	RO
PDO Mapping	No
Value Range	1 to 4
Default Value	4

Sub-Index	1h
Description	Consumer heartbeat time
Access	RW
PDO Mapping	No
Value Range	UNSIGNED32
Default Value	0

3.2.10. Object 1017h: Producer Heartbeat Time

The TC6-ST-CO Controller could be configured to produce a cyclical heartbeat by writing a non-zero value to this object. The value will be given in multiples of 1ms, and a value of 0 shall disable the heartbeat.

Object Description

Index	1017h
Name	Producer heartbeat time
Object Type	VAR
Data Type	UNSIGNED16

Entry Description

Sub-Index	0h
Access	RW
PDO Mapping	No
Value Range	10 to 65535
Default Value	0

3.2.11. Object 1018h: Identity Object

The identity object indicates the data of the TC6-ST-CO Controller, including vendor id, device id, software and hardware version numbers, and the serial number.

In the Revision Number entry at sub-index 3, the format of the data is as shown below

MSB		LSB
Major revision number (object dictionary)	Hardware Revision	Software Version

Object Description

Index	1018h
Name	Identity Object
Object Type	RECORD
Data Type	Identity Record

Entry Description

Sub-Index	0h
Description	Number of entries
Access	RO
PDO Mapping	No
Value Range	4
Default Value	4

Sub-Index	1h
Description	Vendor ID
Access	RO
PDO Mapping	No
Value Range	0x00000055
Default Value	0x00000055 (Axiomatic)

Sub-Index	2h
Description	Product Code
Access	RO
PDO Mapping	No
Value Range	0xAA186001
Default Value	0xAA186001

Sub-Index	3h
Description	Revision Number
Access	RO
PDO Mapping	No
Value Range	UNSIGNED32
Default Value	0x00010000

Sub-Index	4h
Description	Serial Number
Access	RO
PDO Mapping	No
Value Range	UNSIGNED32
Default Value	No

3.2.12. Object 1020h: Verify Configuration

This object can be read to see what date the software (version identified in object 1018h) was compiled. The date is represented as a hexadecimal value showing day/month/year as per the format below. The time value at sub-index 2 is a hexadecimal value showing the time in a 24 hour clock

MSB		LSB
Day (in 1-Byte Hex)	Month (in 1-Byte Hex)	Year (in 2-Byte Hex)
00	00	Time (in 2-Byte Hex)

For example, a value of 0x30042014 would indicate that the software was compiled on April 30th, 2014. A time value of 0x00001842 would indicate it was compiled at 6:42pm.

Object Description

Index	1020h
Name	Verify configuration
Object Type	ARRAY
Data Type	UNSIGNED32

Entry Description

Sub-Index	0h
Description	Number of entries
Access	RO
PDO Mapping	No
Value Range	2
Default Value	2

3.2.13. Object 1029h: Error Behavior

This object controls the state that the TC6-ST-CO Controller will be set into in case of an error of the type associated with the sub-index.

A network fault is flagged when an RPDO is not received within the expected time period defined in the “Event Timer” of the associated communication objects, (see section 3.2.14 for more information) or if a lifeguard or heartbeat message is not received as expected. Input faults are defined in section 1.1, and Power Supply faults are described in section 1.4.

For all sub-indexes, the following definitions hold true:

- 0 = Pre-Operational (node reverts to a pre-operational state when this fault is detected)
- 1 = No State Change (node remains in the same state it was in when the fault occurred)
- 2 = Stopped (node goes into stopped mode when the fault occurs)

Object Description

Index	1029h
Name	Error Behaviour
Object Type	ARRAY
Data Type	UNSIGNED8

Entry Description

Sub-Index	0h
Description	Number of entries
Access	RO
PDO Mapping	No
Value Range	0 to 3
Default Value	3

Sub-Index	1h
Description	Communication Fault
Access	RW
PDO Mapping	No
Value Range	See above
Default Value	0 (Pre-Operational)

Sub-Index	2h
Description	TC Input Error
Access	RW
PDO Mapping	No
Value Range	See above
Default Value	1 (No State Change)

Sub-Index	3h
Description	Fault Detection Error
Access	RW
PDO Mapping	No
Value Range	See above
Default Value	0 (Pre-Operational)

3.2.14. RPDO Behavior

The TC6-ST-CO can support up to four RPDO messages, but, it does not use them. The other RPDO objects are provided simply for compliance with the standard CANopen® Object Dictionary, but are disabled on this module (mapping objects are read-only)

All RPDOs on the TC6-ST-CO use the same default communication parameters, with the PDO IDs set according to the pre-defined connection set described in DS-301. All RPDOs do not exist, there is no RTR allowed, they use 11-bit CAN-IDs (base frame valid) and are event-driven.

Object Description

Index	1400h to 1403h
Name	RPDO communication parameter
Object Type	RECORD
Data Type	PDO Communication Record

Entry Description

Sub-Index	0h
Description	Number of entries
Access	RO
PDO Mapping	No
Value Range	5
Default Value	5

Sub-Index	1h
Description	COB-ID used by RPDO
Access	RW
PDO Mapping	No
Value Range	See value definition in DS-301
Default Value	C0000000h + RPDOx + Node-ID

X	RPDOx ID
1	0200h
2	0300h
3	0400h
4	0500h

Node-ID = Node-ID of the module. The RPDO COB-IDs are automatically updated if the Node-ID is changed by LSS protocol.

80000000h in the COB-ID indicates that the PDO does not exist (destroyed)

04000000h in the COB-ID indicates that there is no RTR allowed on the PDO

Sub-Index	2h
Description	Transmission type
Access	RO
PDO Mapping	No
Value Range	See value definition in DS-301
Default Value	255 (FFh) = Event Driven

Sub-Index	3h
Description	Inhibit Time
Access	RW
PDO Mapping	No
Value Range	See value definition in DS-301
Default Value	0

Sub-Index	4h
Description	Compatibility entry

Access	RW
PDO Mapping	No
Value Range	UNSIGNED8
Default Value	0

Sub-Index	5
Description	Event-timer
Access	RW
PDO Mapping	No
Value Range	See value definition in DS-301
Default Value	0

3.2.15. TPDO Behavior

Per the CANopen® standard DS-301, the following procedure shall be used for re-mapping, and is the same for both RPDOs and TPDOs.

- Destroy the PDO by setting bit **exists** (most significant bit) of sub-index 01h of the according PDO communication parameter to 1b
- Disable mapping by setting sub-index 00h of the corresponding mapping object to 0
- Modify the mapping by changing the values of the corresponding sub-indices
- Enable mapping by setting sub-index 00h to the number of mapped objects
- Create the PDO by setting bit **exists** (most significant bit) of sub-index 01h of the according PDO communication parameter to 0b

The TC6-ST-CO Controller can support up to four TPDO messages. All TPDOs on the TC6-ST-CO Controller use the similar default communication parameters, with the PDO IDs set according to the pre-defined connection set described in DS-301. Most TPDOs do not exist, there is no RTR allowed, they use 11-bit CAN-IDs (base frame valid) and they are all time-driven. While, all have valid default mappings defined (see below), only TPDO1 to TPDO2 are enabled by default (i.e. TPDO exists).

TPDO1 Mapping at Object 1A00h: Default ID 0x180 + Node ID

<i>Sub-Index</i>	<i>Value</i>	<i>Object</i>
0	3	Number of mapped application objects in PDO
1	0x71300110	Thermocouple Input 1 Process Value
2	0x71300210	Thermocouple Input 2 Process Value
3	0x71300310	Thermocouple Input 3 Process Value
4	0	Not used by default

TPDO2 Mapping at Object 1A01h: Default ID 0x280 + Node ID

<i>Sub-Index</i>	<i>Value</i>	<i>Object</i>
0	3	Number of mapped application objects in PDO
1	0x71300410	Thermocouple Input 4 Process Value
2	0x71300510	Thermocouple Input 5 Process Value
3	0x71300610	Thermocouple Input 6 Process Value
4	0	Not used by default

TPDO3 Mapping at Object 1A02h: Default ID 0x380 + Node ID

<i>Sub-Index</i>	<i>Value</i>	<i>Object</i>
0	4	Number of mapped application objects in PDO

1	0x21300110	Average Value of Bank 1 Thermocouples (1 to 3)
2	0x21300210	Average Value of Bank 1 Thermocouples (4 to 6)
3	0x21300310	Average Value of All Thermocouples
4	0x31300010	Cold Junction Temperature Process Value

TPDO4 Mapping at Object 1A03h: Default ID 0x480 + Node ID

Sub-Index	Value	Object
0	0	Number of mapped application objects in PDO
1	0	Not used by default
2	0	Not used by default
3	0	Not used by default
4	0	Not used by default

Since only TPDO1 has a non-zero value transmission rate (i.e. Event Timer in sub-index 5 of communication object), only these TPDOs will be automatically broadcasted when the unit goes into OPERATIONAL mode.

Object Description

Index	1800h to 1803h
Name	TPDO communication parameter
Object Type	RECORD
Data Type	PDO Communication Record

Entry Description

Sub-Index	0h
Description	Number of entries
Access	RO
PDO Mapping	No
Value Range	5
Default Value	5

Sub-Index	1h
Description	COB-ID used by TPDO
Access	RW
PDO Mapping	No
Value Range	See value definition in DS-301
Default Value	40000000h + TPDOx + Node-ID C0000000h + TPDOy + Node-ID

X	TPDOx ID
1	0180h
2	0280h
3	0380h
4	0480h

Node-ID = Node-ID of the module. The TPDO COB-IDs are automatically updated if the Node-ID is changed by LSS protocol.

80000000h in the COB-ID indicates that the PDO does not exist (destroyed)

04000000h in the COB-ID indicates that there is no RTR allowed on the PDO

Sub-Index	2h
Description	Transmission type
Access	RO
PDO Mapping	No
Value Range	See value definition in DS-301
Default Value	254 (FEh) = Event Driven

Sub-Index	3h
Description	Inhibit Time
Access	RW
PDO Mapping	No
Value Range	See value definition in DS-301
Default Value	0

Sub-Index	4h
Description	Compatibility entry
Access	RW
PDO Mapping	No
Value Range	UNSIGNED8
Default Value	0

Sub-Index	5
Description	Event-timer
Access	RW
PDO Mapping	No
Value Range	See value definition in DS-301
Default Value	1000ms (on TPDO1 and TPDO2) 0ms (on, TPDO3,TPDO4)

3.3. Application Objects (DS-404)

<i>Index (hex)</i>	<i>Object</i>	<i>Object Type</i>	<i>Data Type</i>	<i>Access</i>	<i>PDO Mapping</i>
6100	TC Input Field Value	ARRAY	FLOAT32	RO	Yes
6110	TC Sensor Type	ARRAY	UNSIGNED16	RW	No
6112	TC Operating Mode	ARRAY	UNSIGNED8	RW	No
6126	TC Scaling Factor	ARRAY	FLOAT32	RW	No
6127	TC Scaling Offset	ARRAY	FLOAT32	RW	No
6150	TC Status	ARRAY	UNSIGNED8	RO	Yes
7130	TC Input Process Value	ARRAY	INTEGER16	RO	Yes

3.3.1. Object 6100h: TC Input Field Value

This read-only object represents the measured temperature of the associated thermocouple input in °C. When the corresponding sub-index in object 2000h is set to TRUE, the calculated temperature is automatically adjusted for the cold junction temperature compensation.

Object Description

Index	6100h
Name	TC Input Field Value
Object Type	ARRAY
Data Type	FLOAT32

Entry Description

Sub-Index	0h
-----------	----

Description	Largest sub-index supported
Access	RO
PDO Mapping	No
Value Range	6
Default Value	6

Sub-Index	1h to 6h (X = 1 to 6)
Description	TC X Input Field Value
Access	RO
PDO Mapping	Yes
Value Range	-273 °C to 1735 °C
Default Value	No

3.3.2. Object 6110h: TC Sensor Type

This object determines which type of thermocouple is connected to the input. The measured microvolt value is converted to the FV temperature according to this variable. Supported thermocouple types are listed in Table 1.

Object Description

Index	6110h
Name	TC Sensor Type
Object Type	ARRAY
Data Type	UNSIGNED16

Entry Description

Sub-Index	0h
Description	Largest sub-index supported
Access	RO
PDO Mapping	No
Value Range	6
Default Value	6

Sub-Index	1h to 6h (X = 1 to 6)
Description	TC X Sensor Type
Access	RW
PDO Mapping	No
Value Range	See Table 1
Default Value	1 (J-Type)

3.3.3. Object 6112h: TC Operating Mode

This object establishes whether a thermocouple input is considered active. When a sub-index is set to zero (0) “Channel off”, the input is considered disabled and all associated error flags are cleared. To reflect disabled channel 0xFFC00000 (not a number) is written into FV and 0xFFFF (-1) is written into PV of the input. Channel value is also omitted from any averaging calculations.

By default, all six channels are set to 1 – Normal Operation.

Object Description

Index	6112h
Name	TC Operating Mode
Object Type	ARRAY
Data Type	UNSIGNED8

Entry Description

Sub-Index	0h
Description	Largest sub-index supported
Access	RO
PDO Mapping	No
Value Range	6
Default Value	6

Sub-Index	1h to 6h (X = 1 to 6)
Description	TC X Operating Mode
Access	RW
PDO Mapping	No
Value Range	0 or 1
Default Value	1 (Normal Operation)

3.3.4. Object 6126h: TC Scaling Factor

The Object represents the scaling factor by which the thermocouple field value is multiplied to get the process value.

Object Description

Index	6126h
Name	TC Scaling Factor
Object Type	ARRAY
Data Type	FLOAT32

Entry Description

Sub-Index	0h
Description	Largest sub-index supported
Access	RO
PDO Mapping	No
Value Range	6
Default Value	6

Sub-Index	1h to 6h (X = 1 to 6)
Description	TC X Scaling Factor
Access	RW
PDO Mapping	No
Value Range	-1000.0 to 1000.0
Default Value	16.0 [0.0625°C/bit]

3.3.5. Object 6127h: TC Scaling Offset

The object represents the scaling offset which is added to the scaled thermocouple field value to form the process value.

Object Description

Index	6127h
Name	TC Scaling Offset
Object Type	ARRAY
Data Type	FLOAT32

Entry Description

Sub-Index	0h
Description	Largest sub-index supported
Access	RO
PDO Mapping	No
Value Range	6
Default Value	6

Sub-Index	1h to 6h (X = 1 to 6)
Description	TC X Scaling Offset
Access	RW
PDO Mapping	No
Value Range	-10000.0 to 10000.0
Default Value	4368.0 (-273°C * 16)

3.3.6. Object 6150h: TC Input Status

This read-only object reflects the status of the associated thermocouple input field value. Status value zero indicates that the measured data is within normal operating range. The limits for operating range are selected with objects Object 4000h: TC Low Temperature Warning Threshold, Object 4010h: TC High Temperature Warning Threshold and Object 4020h: TC High Temperature Shutdown Threshold.

Reserved	Reserved	Reserved	Reserved	Reserved	Negative Overload	Positive Overload	Data Not Valid
7	6	5	4	3	2	1	0

Value	Meaning
00h	Data Valid and within normal operating range
05h	Open Circuit
04h	Data Valid, but outside of normal range, low warning
02h	Data Valid, but outside of normal range, high warning
03h	Data too high, shutdown

Table 7 – Thermocouple Status Values

Object Description

Index	6150h
Name	TC Status
Object Type	ARRAY
Data Type	UNSIGNED8

Entry Description

Sub-Index	0h
Description	Largest sub-index supported
Access	RO
PDO Mapping	No
Value Range	6
Default Value	6

Sub-Index	1h to 6h (X = 1 to 6)
Description	TC X Status
Access	RO
PDO Mapping	Yes
Value Range	See Table 7
Default Value	0 (Data Valid)

3.3.7. Object 7130h: TC Input Process Value

This read-only object represents the scaled value of the measure thermocouple temperature.

Object Description

Index	7130h
Name	TC Input Process Value
Object Type	ARRAY
Data Type	INTEGER16

Entry Description

Sub-Index	0h
Description	Largest sub-index supported
Access	RO
PDO Mapping	No
Value Range	6
Default Value	6

Sub-Index	1h to 6h (X = 1 to 6)
Description	TC X Input Process Value
Access	RO
PDO Mapping	Yes
Value Range	-32768 to 32767
Default Value	No

3.4. Manufacturer Objects

Index (hex)	Object	Object Type	Data Type	Access	PDO Mapping
2000	CJ Auto Correct	ARRAY	UNSIGNED8	RW	No
2010	TC Input Microvolts	ARRAY	INTEGER32	RO	No
2020	ADC Filter Frequency	VAR	UNSIGNED8	RW	No
2100	AVG Input Field Value	ARRAY	FLOAT32	RO	Yes
2112	AVG Operating Mode	ARRAY	FLOAT32	RW	No
2126	AVG Scaling Factor	ARRAY	FLOAT32	RW	No
2127	AVG Scaling Offset	ARRAY	FLOAT32	RW	No
2130	AVG Input Process Value	ARRAY	INTEGER16	RO	Yes
3100	CJ Input Field Value	VAR	FLOAT32	RO	Yes
3126	CJ Scaling Factor	VAR	FLOAT32	RW	No
3127	CJ Scaling Offset	VAR	FLOAT32	RW	No
3130	CJ Input Process Value	VAR	INTEGER16	RO	Yes
4000	TC Low Temperature Warning Threshold	ARRAY	INTEGER16	RW	No
4010	TC High Temperature Warning Threshold	ARRAY	INTEGER16	RW	No
4020	TC High Temperature Shutdown Threshold	ARRAY	INTEGER16	RW	No
4030	TC Error React Delay	ARRAY	UNSIGNED16	RW	No
5040	FD Field Value	ARRAY	FLOAT32	RO	Yes
5041	FD Set Threshold	ARRAY	INTEGER16	RW	No
5042	FD Clear Threshold	ARRAY	INTEGER16	RW	No
5050	FD Enable Fault Detection	ARRAY	UNSIGNED8	RW	No
5051	FD Error Response Delay	ARRAY	UNSIGNED16	RW	No
5555	Start in Operational Mode	VAR	BOOLEAN	RW	No
5556	Start in Operational NMT Delay	VAR	UNSIGNED16	RW	No

3.4.1. Object 2000h: CJ Auto Correct

This object selects whether measured thermocouple voltage is compensated for on-board cold junction temperature. When set to 1 (TRUE) measured cold junction temperature is automatically used to for compensation.

Object Description

Index	2000h
Name	CJ Auto Correct
Object Type	ARRAY
Data Type	UNSIGNED8

Entry Description

Sub-Index	0h
Description	Largest sub-index supported
Access	RO
PDO Mapping	No
Value Range	6
Default Value	6

Sub-Index	1h to 6h (X = 1 to 6)
Description	Use CJ compensation for thermocouple X
Access	RO
PDO Mapping	No
Value Range	0 or 1
Default Value	1 (TRUE)

3.4.2. Object 2010h: TC Input Microvolts

This read-only object is available for diagnostic purposes. It reflects measured thermocouple voltage in mV. If Cold Junction compensation is used this value has already been compensated for the cold junction temperature.

Object Description

Index	2010h
Name	TC Input Microvolts
Object Type	ARRAY
Data Type	INTEGER32

Entry Description

Sub-Index	0h
Description	Largest sub-index supported
Access	RO
PDO Mapping	No
Value Range	6
Default Value	6

Sub-Index	1h to 6h (X = 1 to 6)
Description	TC X Input voltage in mV
Access	RO
PDO Mapping	No
Value Range	Depends on sensor type
Default Value	No

3.4.3. Object 2020h: ADC Filter Frequency

This object defines which ADC rejection mode is programmed for the thermocouple channel ADCs.

Object Description

Index	2020h
Name	ADC Filter Frequency
Object Type	VAR
Data Type	UNSIGNED8

Entry Description

Sub-Index	0h
Access	RW
PDO Mapping	No

Value Range	50Hz or 60Hz
Default Value	60

3.4.4. Object 2100h: AVG Input Field Value

This read-only object reflects the calculated average of a given subset of thermocouple inputs. Channels with invalid input data (i.e. disabled or open circuit) are not used in the average calculations. The average input field value is calculated by adding together the temperature of all valid channels and then dividing by the number of valid inputs.

Object Description

Index	2100h
Name	AVG Input Field Value
Object Type	ARRAY
Data Type	FLOAT32

Entry Description

Sub-Index	0h
Description	Largest sub-index supported
Access	RO
PDO Mapping	No
Value Range	3
Default Value	3

Sub-Index	1h
Description	Bank 1 Average FV (TC1 to TC3)
Access	RO
PDO Mapping	Yes
Value Range	-273°C to 1735°C
Default Value	No

Sub-Index	2h
Description	Bank 2 Average FV (TC4 to TC6)
Access	RO
PDO Mapping	Yes
Value Range	-273°C to 1735°C
Default Value	No

Sub-Index	3h
Description	Total Average FV (TC1 to TC6)
Access	RO
PDO Mapping	Yes
Value Range	-273°C to 1735°C
Default Value	No

3.4.5. Object 2112h: AVG Operating Mode

This object determines if the averaging calculation is performed for the given sub-index. When set to 1 – Normal Operation, averaging is performed. Otherwise, value 0xFFC00000 (not a number) is written into AVG FV and 0xFFFF (-1) is written into AVG PV in the corresponding sub-index.

Object Description

Index	2112h
Name	AVG Operating Mode
Object Type	ARRAY
Data Type	UNSIGNED8

Entry Description

Sub-Index	0h
Description	Largest sub-index supported
Access	RO
PDO Mapping	No
Value Range	3
Default Value	3

Sub-Index	1h to 3h (X = 1 to 3)
Description	AVG X Operating Mode
Access	RW
PDO Mapping	No
Value Range	0 or 1
Default Value	1 – Normal Operation

3.4.6. Object 2126h: AVG Scaling Factor

This object represents the scaling factor by which the average field value is multiplied to form the process value.

Object Description

Index	2126h
Name	AVG Scaling Factor
Object Type	ARRAY
Data Type	FLOAT32

Entry Description

Sub-Index	0h
Description	Largest sub-index supported
Access	RO
PDO Mapping	No
Value Range	3
Default Value	3

Sub-Index	1h to 3h (X = 1 to 3)
Description	AVG X Scaling Factor
Access	RW
PDO Mapping	No
Value Range	-1000.0 to 1000.0

Default Value	16.0 [0.0625°C/bit]
---------------	---------------------

3.4.7. Object 2127h: AVG Scaling Offset

This object represents the scaling offset which is added to the scaled average field value to form the process value.

Object Description

Index	2127h
Name	AVG Scaling Offset
Object Type	ARRAY
Data Type	FLOAT32

Entry Description

Sub-Index	0h
Description	Largest sub-index supported
Access	RO
PDO Mapping	No
Value Range	3
Default Value	3

Sub-Index	1h to 3h (X = 1 to 3)
Description	AVG X Scaling Offset
Access	RW
PDO Mapping	No
Value Range	-10000.0 to 10000.0
Default Value	4368.0 (-273°C * 16)

3.4.8. Object 2130h: AVG Input Process Value

This read-only object represents the scaled value of the measured average temperature.

Object Description

Index	2130h
Name	AVG Input Process Value
Object Type	ARRAY
Data Type	INTEGER16

Entry Description

Sub-Index	0h
Description	Largest sub-index supported
Access	RO
PDO Mapping	No
Value Range	3
Default Value	3

Sub-Index	1h to 3h (X = 1 to 3)
Description	AVG X Input Process Value

Access	RO
PDO Mapping	Yes
Value Range	-32768 to 32767
Default Value	No

3.4.9. Object 3100h: CJ Input Field Value

This read-only object reflects the measured cold junction temperature value in °C.

Object Description

Index	3100h
Name	CJ Input Field Value
Object Type	VAR
Data Type	FLOAT32

Entry Description

Sub-Index	0h
Access	RO
PDO Mapping	Yes
Value Range	-40°C to 110°C
Default Value	No

3.4.10. Object 3126h: CJ Scaling Factor

This object represents the scaling factor by which the cold junction field value is multiplied to form the process value.

Object Description

Index	3126h
Name	CJ Scaling Factor
Object Type	VAR
Data Type	FLOAT32

Entry Description

Sub-Index	0h
Access	RW
PDO Mapping	No
Value Range	-1000.0 to 1000.0
Default Value	16.0 [0.0625°C/bit]

3.4.11. Object 3127h: CJ Scaling Offset

This object represents the scaling offset which is added to the scaled cold junction field value to form the process value.

Object Description

Index	3127h
-------	-------

Name	CJ Scaling Offset
Object Type	VAR
Data Type	FLOAT32

Entry Description

Sub-Index	0h
Access	RW
PDO Mapping	No
Value Range	-10000.0 to 10000.0
Default Value	4368.0 [-273°C * 16]

3.4.12. Object 3130h: CJ Input Process Value

This read-only object represents the scaled value of the measured cold junction temperature.

Object Description

Index	3130h
Name	CJ Input Process Value
Object Type	VAR
Data Type	FLOAT32

Entry Description

Sub-Index	0h
Access	RO
PDO Mapping	Yes
Value Range	-32768 to 32767
Default Value	No

3.4.13. Object 4000h: TC Low Temperature Warning Threshold

This object sets the low threshold of the normal operating temperature range for each thermocouple's input field value (Object 6100h: TC Input Field Value). Any FV value below this limit flags a low warning in the corresponding status byte (Object 6150h: TC Input Status), as well as setting an EMCY code in the predefined error field (Object 1003h: Predefined Error Field). Threshold value is interpreted with a resolution of 0.1°C/bit.

Object Description

Index	4000h
Name	TC Low Temperature Warning Threshold
Object Type	ARRAY
Data Type	INTEGER16

Entry Description

Sub-Index	0h
Description	Largest sub-index supported
Access	RO
PDO Mapping	No
Value Range	6

Default Value	6
---------------	---

Sub-Index	1h to 6h (X = 1 to 6)
Description	TC X Low Warning Threshold
Access	RW
PDO Mapping	No
Value Range	-2730 to TC X High Warning Temp -100
Default Value	-200 [-20°C]

3.4.14. Object 4010h: TC High Temperature Warning Threshold

This object sets the high threshold of the normal operating temperature range for each thermocouple's input field value (Object 6100h: TC Input Field Value). Any FV value below this limit flags a high warning in the corresponding status byte (Object 6150h: TC Input Status), as well as setting an EMCY code in the predefined error field (Object 1003h: Predefined Error Field). Threshold value is interpreted with a resolution of 0.1°C/bit.

Object Description

Index	4010h
Name	TC High Temperature Warning Threshold
Object Type	ARRAY
Data Type	INTEGER16

Entry Description

Sub-Index	0h
Description	Largest sub-index supported
Access	RO
PDO Mapping	No
Value Range	6
Default Value	6

Sub-Index	1h to 6h (X = 1 to 6)
Description	TC X High Warning Threshold
Access	RW
PDO Mapping	No
Value Range	TC X Low Warning Temp + 100 to TC X High Shutdown Temp -100
Default Value	1250 [125°C]

3.4.15. Object 4020h: TC High Temperature Shutdown Threshold

This object sets the high threshold of the shutdown operating temperature range for each thermocouple's input field value (Object 6100h: TC Input Field Value). Any FV value below this limit flags a high shutdown in the corresponding status byte (Object 6150h: TC Input Status), as well as setting an EMCY code in the predefined error field (Object 1003h: Predefined Error Field). Threshold value is interpreted with a resolution of 0.1°C/bit.

Object Description

Index	4020h
Name	TC High Temperature Shutdown Threshold
Object Type	ARRAY
Data Type	INTEGER16

Entry Description

Sub-Index	0h
Description	Largest sub-index supported
Access	RO
PDO Mapping	No
Value Range	6
Default Value	6

Sub-Index	1h to 6h (X = 1 to 6)
Description	TC X High Shutdown Threshold
Access	RW
PDO Mapping	No
Value Range	TC X High Warning Temp + 100 to 17350
Default Value	2500 [250°C]

3.4.16. Object 4030h: TC Error React Delay

This object defines how long detected fault must be active before error reaction is triggered. If the temperature returns within defined limit during this period, the fault will not be flagged in the status byte (Object 6150h: TC Input Status), nor will an EMCY code be generated in the predefined error field (Object 1003h: Predefined Error Field).

Object Description

Index	4030h
Name	TC Error React Delay
Object Type	ARRAY
Data Type	UNSIGNED16

Entry Description

Sub-Index	0h
Description	Largest sub-index supported
Access	RO
PDO Mapping	No
Value Range	6
Default Value	6

Sub-Index	1h to 6h (X = 1 to 6)
Description	TC X Error React Delay
Access	RW
PDO Mapping	No
Value Range	0ms to 60000ms
Default Value	5000ms

3.4.17. Object 5040h: FD Field Value

This read-only object is available for diagnostic feedback purposes. It reflects the measured voltage powering the controller as well as the internal microcontroller temperature. Sub-index 1 is microcontroller temperature value, which is used for FD1 over temperature detection, Sub-index 2 is power supply voltage, which is used in FD2 power over voltage fault detection and FD3 power under voltage detection. The values are directional and suitable only for monitoring that measured quantities stay roughly within normal operation. The physical unit for this object is volts and °C, respectively.

Object Description

Index	5040h
Name	FD Field Value
Object Type	VARIABLE
Data Type	FLOAT32

Entry Description

Sub-Index	0h
Access	RO
PDO Mapping	Yes
Value Range	2
Default Value	2

Sub-Index	1h
Description	Microcontroller Temperature (FD1)
Access	RO
PDO Mapping	Yes
Value Range	0 to 1250 [°C x 10]
Default Value	0

Sub-Index	2h
Description	Power Supply Voltage (FD2 and FD3)
Access	RO
PDO Mapping	Yes
Value Range	0 to 500 [V x 10]
Default Value	0

3.4.18. Object 5041h: FD Set Threshold

This object sets the value that will flag a fault detection error in the TC6-ST-CO if the measured field value (5040h) goes above (FD 1 and FD 2) or below (FD 3) this limit. If error checking on the fault is enabled by object 5050h, then the module will flag an appropriate error on that channel. This value must be in the same units as the field value for the fault, as determined by the sub-index.

Object Description

Index	5041h
Name	FD Set Threshold
Object Type	ARRAY
Data Type	UNSIGNED16

Entry Description

Sub-index	0h
Description	Number of entries
Access	RO
PDO Mapping	No
Value Range	3
Default Value	3

Sub-index	1h
Description	FD1 Microcontroller temperature high limit
Access	RW
PDO Mapping	No
Value Range	5042h at sub-index 1 to 1250 [°C x 10]
Default Value	1100 (110.0°C)

Sub-index	2h
Description	FD2 Power supply voltage high limit
Access	RW
PDO Mapping	No
Value Range	5042h at sub-index 2 to 1000 [V x 10]
Default Value	500 (50.0V)

Sub-index	3h
Description	FD3 Power supply voltage low limit
Access	RW
PDO Mapping	No
Value Range	80 to 5042h at sub-index 3 [V x 10]
Default Value	90 (9.0V)

3.4.19. Object 5042h: FD Clear Threshold

This object sets the value that will clear a fault detection error in the TC6-ST-CO if the measured field value (5040h) goes below (FD 1 and FD 2) or above (FD 3) this threshold. This value must be in the same units as the field value for the fault, as determined by the sub-index.

Object Description

Index	5042h
Name	FD Clear Threshold
Object Type	ARRAY
Data Type	UNSIGNED16

Entry Description

Sub-index	0h
Description	Number of entries
Access	RO
PDO Mapping	No
Value Range	3
Default Value	3
Sub-index	1h

Description	FD1 Clear Threshold
Access	RW
PDO Mapping	No
Value Range	500 to 5041h at sub-index 1 [°C x 10]
Default Value	850 (85.0°C)

Sub-index	2h
Description	FD2 Clear Threshold
Access	RW
PDO Mapping	No
Value Range	5042h at sub-index 3 to 5041h at sub-index 2 [V x 10]
Default Value	480 (48.0V)

Sub-index	3h
Description	FD3 Clear Threshold
Access	RW
PDO Mapping	No
Value Range	5041h at sub-index 3 to 5042h at sub-index 2 [V x 10]
Default Value	120 (12.0V)

3.4.20. Object 5050h: FD Enable Fault Detection

This object enables or disables the fault detection error-checking feature for each fault detectable by the TC6-ST-CO.

Object Description

Index	5050h
Name	FD Enable Fault Detection
Object Type	ARRAY
Data Type	UNSIGNED8

Entry Description

Sub-index	0h
Description	Number of entries
Access	RO
PDO Mapping	No
Value Range	2
Default Value	2

Sub-index	1h
Description	Enable fault detection for microcontroller temperature (FD1)
Access	RW
PDO Mapping	No
Value Range	0 or 1
Default Value	1 (TRUE)

Sub-index	2h
-----------	----

Description	Enable fault detection for power supply voltage (both FD2 and FD3)
Access	RW
PDO Mapping	No
Value Range	0 or 1
Default Value	1 (TRUE)

3.4.21. Object 5051h: FD Error Response Delay

This object defines how long detected fault must be active before error reaction is triggered. If the FD field value returns within defined limit during this period, the fault will not be flagged, nor will an EMCY code be generated in the predefined error field (Object 1003h: Predefined Error Field).

Object Description

Index	5051h
Name	FD Error Response Delay
Object Type	ARRAY
Data Type	UNSIGNED16

Entry Description

Sub-index	0h
Description	Number of entries
Access	RO
PDO Mapping	No
Value Range	2
Default Value	2

Sub-index	1h
Description	FD1 Error Response Delay
Access	RW
PDO Mapping	No
Value Range	0 to 10000 [ms]
Default Value	5000 [ms]

Sub-index	2h
Description	FD2 and FD3 Error Response Delay
Access	RW
PDO Mapping	No
Value Range	0 to 10000 [ms]
Default Value	5000 [ms]

3.4.22. Object 5555h: Start in Operational Mode

This object allows the unit to start in Operational mode without requiring the presence of a CANopen® Master on the network. It is intended to be used only when running the TC6-ST-CO controller as a stand-alone module or in network solely comprising of slave modules. This should always be set to 0 – “No action” whenever the controller is connected to a standard master/slave network.

Object Description

Index	5555h
Name	Start in Operational Mode
Object Type	VAR
Data Type	UNSIGNED8

Entry Description

Sub-Index	0h
Access	RW
PDO Mapping	No
Value Range	See Table 3
Default Value	0 [No action]

3.4.23. Object 5556h: Start in Operational NMT Delay

This object defines delay in milliseconds before sending the NMT message, if object 5555h is set to 2 – “Start in operational mode and send NMT for starting other devices”.

Object Description

Index	5556h
Name	Start in Operational NMT Delay
Object Type	VAR
Data Type	UNSIGNED16

Entry Description

Sub-Index	0h
Access	RW
PDO Mapping	No
Value Range	0ms to 65000ms
Default Value	1000ms

APPENDIX A - TECHNICAL SPECIFICATION

Technical Specifications:

Specifications are indicative and subject to change. Actual performance will vary depending on the application and operating conditions. Users should satisfy themselves that the product is suitable for use in the intended application. All our products carry a limited warranty against defects in material and workmanship. Please refer to our Warranty, Application Approvals/Limitations and Return Materials Process as described on <https://www.axiomatic.com/service/>.

Inputs

Power Supply Input	12 or 24Vdc nominal (9...36Vdc power supply range) NB. The maximum total power consumption is <1.5 Watts.
Protection	Surge and reverse polarity protection are provided.
Isolation	Full isolation of each channel from the CAN line, other inputs and power supply. Isolation voltage is 1500 Vac (rms) or 2550V for 1 sec. for all channels to power and 50V (rms) for all channels to CAN interface.
All Inputs	In P/N: AX186001, the following Thermocouple (TC) types are supported. 6 Type J, K, B, E, N, R, S or T The device reads mV signals from the supported Thermocouples. B = 0 to 13.82 mV E = -9.835 to 76.373 mV J = -8.095 to 69.553 mV K = -6.458 to 54.886 mV N = -4.345 to 47.513 mV R = -0.226 to 21.101 mV S = -0.236 to 18.693 mV T = -6.258 to 20.872 mV (Other TC types are available on request.)
Resolution	Temperature data is measured with a resolution of 0.1 °C. When sending data to the J1939 bus, one-byte parameters have a resolution of 1°C/ bit, an offset of -40°C and a range of -40 °C to 210 °C. Two-byte parameters have resolution of 0.03125 °C / bit and a range of -273 °C to 1735 °C
Drift	Overall drift with temperature is 50ppm/°C of span (maximum).
Accuracy	+/-1 °C throughout the entire range of the thermocouple input
Input Functionality	All input channels are completely independent of each other and can read the thermocouple temperatures at the same time. Temperature is measured in °C with a 0.1°C resolution. By default, the Thermocouple Scanner transmits the process value (object \$7130) according to the device profile in CiA Standard DS-404
Measurement Rate	The measurement rate is 6 scans/Sec. All channels are measured simultaneously. The update rate is 165 mSec.
Common Mode	Common mode rejection is >110 db@ 5V p-p (programmable for either 50 or 60 Hz). Common mode input range is +/- 4 V minimum.

Shield	Four shield connections are provided.
Ground	Four analog ground connections are provided.

General Specifications

Operating Conditions	-40 to 85°C (-40 to 185°F)
Weight	0.55 lb. (0.25 kg)
Protection	IP67; Unit is conformal coated within the housing.
Vibration	MIL-STD-202G, Test 204D and 214A (Sine and Random) 10 g peak (Sine) 7.68 Grms peak (Random)
Shock	MIL-STD-202G, Test 213B 50 g
Microprocessor	STM32F405RG, 32-bit, 1MByte flash memory
Control Logic	Standard embedded software is provided. User programmable functionality using SDO object ac DS-301. <i>Refer to the user manual for details.</i> (Application-specific control logic is available on request.)
User Interface	.EDS provided to interface to standard CANopen® tools
CAN Interface	1 CAN 2.0Bport, protocol CiA CANopen® By default, the Thermocouple Scanner transmits the process value (object \$7130) according to the device profile in CiA Standard DS-404
Termination	It is necessary to terminate the network with external termination resistors. The resistors are 120 Ohm, 0.25W minimum, metal film or similar type. They could be placed between CAN_H and CAN_L terminals at both ends of the network.
Electrical Connections	<p>Refer to Table 2.0.</p> <div style="text-align: center;">  <p>Key Arrangement B (black)</p> <p>Key Arrangement A (grey)</p> <p>FRONT VIEW 24 PIN RECEPTACLE</p> </div> <p>24-pin receptacle (equivalent TE Deutsch P/N: DTM13-12PA-12PB-R008)</p> <p>Mating plugs kits are available on request and include Deutsch DTM06-12SA and DTM06-12SB with 2 wedgelocks (WM12S) and 24 contacts (0462-201-20141).</p> <p>20 AWG wire is recommended for use with contacts 0462-201-20141.</p>

Table 2.0 - Typical Connections, AX186000

Grey Connector		Black Connector	
Pin #	Function	Pin #	Function
1	TC IN5+	1	TC IN1+
2	TC IN5-	2	TC IN1-
3	TC 5_Shield	3	TC1_Shield
4	TC IN6+	4	TC IN2+
5	Frame GND	5	TC IN2-
6	Battery -	6	TC2_Shield
7	Battery +	7	TC3_Shield
8	TC 6_Shield	8	TC IN3-
9	TC IN6-	9	TC IN3+
10	CAN_L	10	TC4_Shield
11	CAN_H	11	TC IN4-
12	CAN_Shield	12	TC IN4+

Enclosure and Dimensions

High Temperature Nylon PCB Enclosure – (Equivalent TE Deutsch P/N: EEC-325X4B)
 4.677 x 5.254 x 1.417 inches 118.80 x 133.45 x 35.99 mm (W x L x H excluding mating plug)
 Refer to the Dimensional Drawing, Figure 1.0.

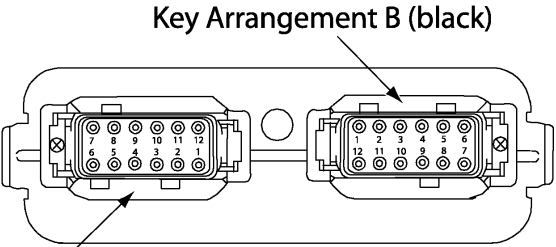
OUR PRODUCTS

AC/DC Power Supplies
Actuator Controls/Interfaces
Automotive Ethernet Interfaces
Battery Chargers
CAN Controls, Routers, Repeaters
CAN/WiFi, CAN/Bluetooth, Routers
Current/Voltage/PWM Converters
DC/DC Power Converters
Engine Temperature Scanners
Ethernet/CAN Converters,
Gateways, Switches
Fan Drive Controllers
Gateways, CAN/Modbus, RS-232
Gyroscopes, Inclinometers
Hydraulic Valve Controllers
Inclinometers, Triaxial
I/O Controls
LVDT Signal Converters
Machine Controls
Modbus, RS-422, RS-485 Controls
Motor Controls, Inverters
Power Supplies, DC/DC, AC/DC
PWM Signal Converters/Isolators
Resolver Signal Conditioners
Service Tools
Signal Conditioners, Converters
Strain Gauge CAN Controls
Surge Suppressors

OUR COMPANY

Axiomatic provides electronic machine control components to the off-highway, commercial vehicle, electric vehicle, power generator set, material handling, renewable energy and industrial OEM markets. ***We innovate with engineered and off-the-shelf machine controls that add value for our customers.***

QUALITY DESIGN AND MANUFACTURING

We have an ISO9001:2015 registered design/manufacturing facility in Canada.

WARRANTY, APPLICATION APPROVALS/LIMITATIONS

Axiomatic Technologies Corporation reserves the right to make corrections, modifications, enhancements, improvements, and other changes to its products and services at any time and to discontinue any product or service without notice. Customers should obtain the latest relevant information before placing orders and should verify that such information is current and complete. Users should satisfy themselves that the product is suitable for use in the intended application. All our products carry a limited warranty against defects in material and workmanship. Please refer to our Warranty, Application Approvals/Limitations and Return Materials Process at <https://www.axiomatic.com/service/>.

COMPLIANCE

Product compliance details can be found in the product literature and/or on axiomatic.com. Any inquiries should be sent to sales@axiomatic.com.

SAFE USE

All products should be serviced by Axiomatic. Do not open the product and perform the service yourself.



This product can expose you to chemicals which are known in the State of California, USA to cause cancer and reproductive harm. For more information go to www.P65Warnings.ca.gov.

SERVICE

All products to be returned to Axiomatic require a Return Materials Authorization Number (RMA#) from sales@axiomatic.com. Please provide the following information when requesting an RMA number:

- Serial number, part number
- Runtime hours, description of problem
- Wiring set up diagram, application and other comments as needed

DISPOSAL

Axiomatic products are electronic waste. Please follow your local environmental waste and recycling laws, regulations and policies for safe disposal or recycling of electronic waste.

CONTACTS

Axiomatic Technologies Corporation
1445 Courtneypark Drive E.
Mississauga, ON
CANADA L5T 2E3
TEL: +1 905 602 9270
FAX: +1 905 602 9279
www.axiomatic.com
sales@axiomatic.com

Axiomatic Technologies Oy
Höytämöntie 6
33880 Lempäälä
FINLAND
TEL: +358 103 375 750
www.axiomatic.com
salesfinland@axiomatic.com