



**USER MANUAL UMAX184200**

# **20 PT1000 RTD SCANNER, WITH CAN SAE J1939**

## **USER MANUAL**

**P/N: AX184200**

## VERSION HISTORY

<b>Version</b>	<b>Date</b>	<b>Author</b>	<b>Modification</b>
1.00	March 10, 2020	Ilona Korpelainen	Initial Draft
1.00A	June 1, 2023	Ilona Korpelainen	Updated to match firmware V1.00 - Removed LVDTs - Added auto baud rate
-	June 14, 2023	M Ejaz	Marketing review
-	June 15, 2023	M Ejaz	Removed preliminary tag
1.01	August 9, 2023	M Ejaz	Added pinout for Pin# 40
1.02	August 29, 2023	Kiril Mojsov	Performed Legacy Updates

## ACRONYMS

ACK	Positive Acknowledgement (from SAE J1939 standard)
BATT +/-	Battery positive (a.k.a. Vps) or Battery Negative (a.k.a. GND)
DM	Diagnostic Message (from SAE J1939 standard)
DTC	Diagnostic Trouble Code (from SAE J1939 standard)
EA	Axiomatic Electronic Assistant (A Service Tool for Axiomatic ECUs)
ECU	Electronic Control Unit (from SAE J1939 standard)
GND	Ground reference (a.k.a. BATT-)
I/O	Inputs and Outputs
MAP	Memory Access Protocol
NAK	Negative Acknowledgement (from SAE J1939 standard)
PDU1	A format for messages that are to be sent to a destination address, either specific or global (from SAE J1939 standard)
PDU2	A format used to send information that has been labeled using the Group Extension technique, and does not contain a destination address.
PGN	Parameter Group Number (from SAE J1939 standard)
PropA	Message that uses the Proprietary A PGN for peer-to-peer communication
PropB	Message that uses a Proprietary B PGN for broadcast communication
PWM	Pulse Width Modulation
RPM	Rotations per Minute
RTD	Resistance Temperature Detector
SPN	Suspect Parameter Number (from SAE J1939 standard)
TP	Transport Protocol
Vps	Voltage Power Supply (a.k.a. BATT+)

# TABLE OF CONTENTS

<b>1. OVERVIEW OF CONTROLLER</b> .....	<b>8</b>
1.1. RTD Input Function Blocks .....	9
1.2. Averaging.....	16
1.3. Diagnostic Function Blocks .....	17
1.4. CAN Transmit Message Function Block.....	20
1.4.1. CAN Transmit Message Setpoints .....	21
1.4.2. CAN Transmit Signal Setpoints .....	21
1.5. CAN Receive Function Block .....	22
1.6. Available Control Sources .....	22
<b>2. INSTALLATION INSTRUCTIONS</b> .....	<b>24</b>
2.1. Dimensions and Pinout.....	24
<b>3. OVERVIEW OF J1939 FEATURES</b> .....	<b>26</b>
3.1. Introduction to Supported Messages .....	26
3.2. NAME, Address and Software ID .....	27
<b>4. ECU SETPOINTS ACCESSED WITH AXIOMATIC ELECTRONIC ASSISTANT</b> .....	<b>30</b>
4.1. J1939 Network Parameters .....	30
4.2. RTD Input Setpoints .....	31
4.3. Averaging Setpoints.....	32
4.4. CAN Transmit Setpoints .....	33
4.5. CAN Receive Setpoints .....	36
4.6. General Diagnostics Options .....	37
4.7. Diagnostics Blocks.....	38
<b>5. REFLASHING OVER CAN WITH EA BOOTLOADER</b> .....	<b>41</b>
<b>APPENDIX A - TECHNICAL SPECIFICATION</b> .....	<b>A-1</b>

Table 1 – RTD Coefficient Options.....	9
Table 2 – Predefined Callendar Van Dusen Constants .....	9
Table 3 – Supported Suspect Parameter Numbers .....	15
Table 4 – Lamp Set by Event in DM1 Options .....	19
Table 5 – FMI for Event Options.....	19
Table 6 – Low Fault FMIs and corresponding High Fault FMIs .....	20
Table 7 – CAN Transmit Data Type Options.....	21
Table 8 – Available Control Sources and Numbers .....	23
Table 9 – AX184200 DT12-12PA Connector Pinout.....	24
Table 10 – AX184200 DRC13-40PB Connector Pinout.....	25
Table 11 – J1939 Network Setpoints.....	30
Table 12 – RTD Input Setpoints .....	31
Table 13 – Averaging Setpoints .....	32
Table 14 – CAN Transmit Message Setpoints .....	35
Table 15 – CAN Receive Setpoints.....	36
Table 16 – General Diagnostics Options Setpoints.....	37
Table 17 – Diagnostic Block Setpoints .....	40

Figure 1 – AX18400 Block Diagram ..... 8

Figure 2 – Double Minimum and Maximum Error Thresholds..... 18

Figure 3 – Analog source to Digital input ..... 23

Figure 4 – AX184200 Dimensional Drawing ..... 24

Figure 5 – AX184200 DRC13-40PA Connector ..... 25

Figure 6 – AX184200 2-wire..... 25

Figure 7 – Screen Capture of J1939 Setpoints ..... 30

Figure 8 – Screen Capture of RTD Input Setpoints..... 31

Figure 9 – Screen Capture of Averaging Setpoints..... 32

Figure 10 – Screen Capture of CAN Transmit Message Setpoints..... 34

Figure 11 – Screen Capture of CAN Receive Message Setpoints..... 36

Figure 12 – Screen Capture of General Diagnostics Options Setpoints ..... 37

Figure 13 – Screen Capture of Diagnostic Block Setpoints ..... 38

## REFERENCES

J1939	Recommended Practice for a Serial Control and Communications Vehicle Network, SAE, April 2011
J1939/21	Data Link Layer, SAE, December 2010
J1939/71	Vehicle Application Layer, SAE, March 2011
J1939/73	Application Layer-Diagnostics, SAE, February 2010
J1939/81	Network Management, SAE, May 2003
TDAX184200	Technical Datasheet, 20 Pt1000 RTD Scanner, Axiomatic Technologies 2020
UMAX07050x	User Manual V5.13.85, Axiomatic Electronic Assistant and USB-CAN, Axiomatic Technologies, December 2023

***This document assumes the reader is familiar with the SAE J1939 standard. Terminology from the standard is used, but not described in this document.***



NOTE: This product is supported by Axiomatic Electronic Assistant **VX.XX.XX** and higher.

# 1. OVERVIEW OF CONTROLLER

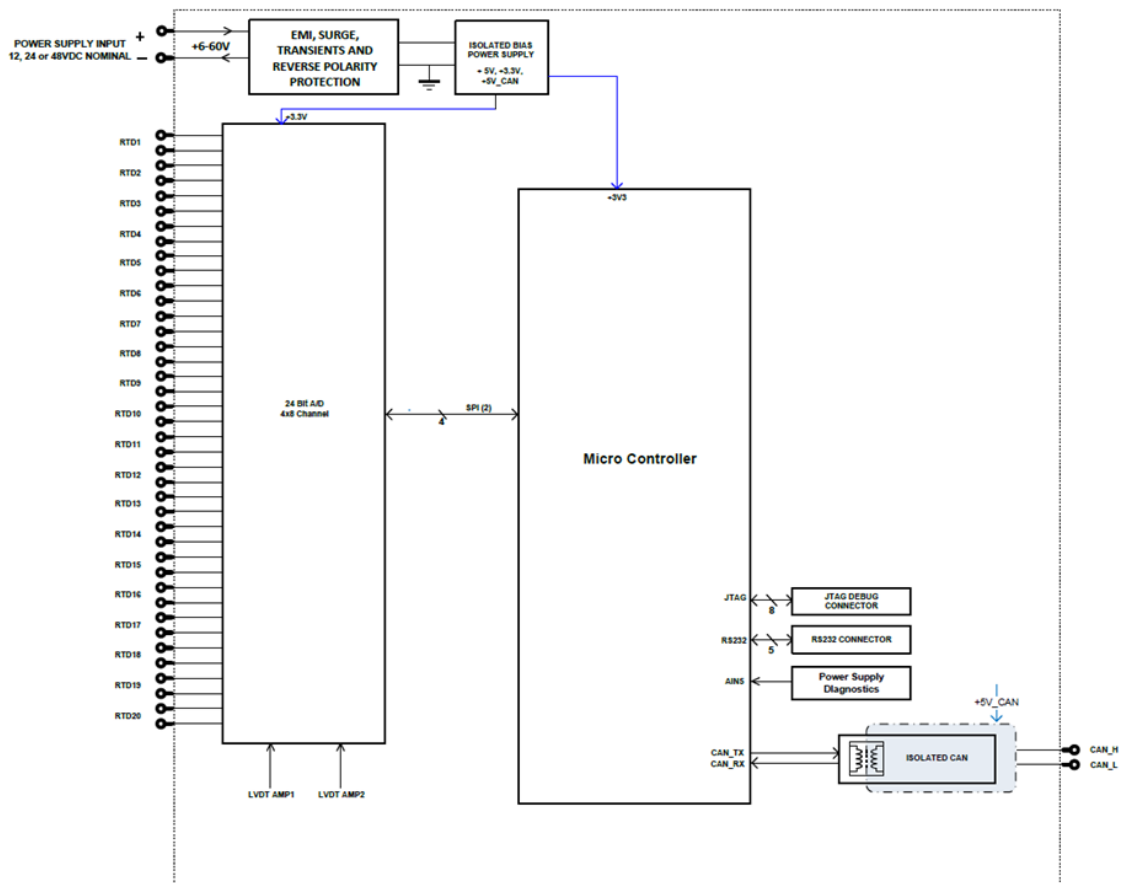

Figure 1 – AX18400 Block Diagram

The 20 Pt1000 RTD Scanner monitors twenty 2-wire RTD inputs and provides the temperature information over a SAE J1939 CAN bus. All channels of temperature data are automatically sent over the CAN bus when power is applied with no additional programming or configuration needed.

Passive baud rate detection is used to determine the CAN bus baud rate. Supported baud rate options are 250kbit/s, 500kbit/s, and 1Mbit/s. Successfully detected baud rate is saved on flash and used as initial baud rate on next startup. Passive baud rate detection requires there to be valid CAN frames on the bus. If there are no other CAN devices connected to the bus, the desired baud rate should be detected in advance. For example, by performing configuration using the chosen baud rate.

A *Windows*-based Axiomatic Electronic Assistant (EA) is used to configure the controller via an USB-CAN (AX070501) device. Configurable properties, EA setpoints, are outlined in chapter 4. Setpoint configuration can be saved in a file which can be used to easily program the same configuration into another 20 Pt1000 RTD Scanner. Throughout this document EA setpoint names are referred to with bolded text in double-quotes and the setpoint option is referred to with italicized text in single-quotes. For example, “**RTD Coefficient**” setpoint set to option ‘*IEC 0.00385*’.

In this document, the configurable properties of the ECU are divided into function blocks, namely RTD Input Function Block, Averaging, Diagnostic Function Block, CAN Transmit Message Function



Block and CAN Receive Message Function Block. These function blocks are presented in detail in the next subchapters.

## 1.1. RTD Input Function Blocks

There are twenty RTD channels on the AX184200, each with two pins at the connector for 2-wire connections. Resistance of the RTD is determined with dedicated onboard ADCs.

The resistance measurement is implemented by deriving both reference voltage, for the ADC, and measurement excitation voltage from the same source, thus errors common to both voltages, such as temperature drift and noise, cancel out each other.

Temperature value of the RDT channel is calculated from the measured resistance by using Callendar Van Dusen equation. According to IEC751, the non-linearity of the platinum thermometer can be expressed as:

$$R_t = R_0[1 + At + Bt^2 + C(t - 100)t^3] \quad \text{in which C is only applicable when } t < 0 \text{ } ^\circ\text{C}.$$

The coefficients A, B and C for the standard sensor are stated at IEC751.

The AX184200 has five predefined Callendar Van Dusen Coefficient sets. Predefined coefficient set is selected with “**RTD Coefficient**” setpoint. “**RTD Coefficient**” setpoint options are listed in Table 1 and associated Callendar Van Dusen Constants are listed in Table 2. The ‘User Defined’ option allows Callendar Van Dusen constants to be manually set to whatever is defined for the connected sensor.

0	<i>IEC 0.00385</i>
1	<i>JIS 0.003916</i>
2	<i>US 0.003902</i>
3	<i>Legacy 0.003920</i>
4	<i>SAMA 0.003923</i>
5	<i>User Defined</i>

**Table 1 – RTD Coefficient Options**

	<b>Constant A (E-03)</b>	<b>Constant B (E-07)</b>	<b>Constant C (E-012)</b>
<b>0</b>	<i>3.90830</i>	<i>-5.77500</i>	<i>-4.18301</i>
<b>1</b>	<i>3.974673</i>	<i>-5.89730</i>	<i>-4.35300</i>
<b>2</b>	<i>3.96</i>	<i>-5.93</i>	<i>-4.30</i>
<b>3</b>	<i>3.9848</i>	<i>-5.870</i>	<i>-4.000</i>
<b>4</b>	<i>3.981531</i>	<i>-5.853116</i>	<i>-4.354530</i>
<b>5</b>	<i>User Defined</i>	<i>User Defined</i>	<i>User Defined</i>

**Table 2 – Predefined Callendar Van Dusen Constants**

Temperature SPN for the RTD channel can be selected with “Temperature Suspect Parameter Number” setpoint. The SPN drop list includes all temperature SPNs from the J1939-71 standard published up to January of 2009. List of supported SPNs and associated size, PGN, transmit rate, index and priority are listed in Table 3.

Each SPN that is supported by the 20 Pt1000 RTD Scanner has a predefined size (1 or 2 bytes) and consequently resolution and offset, associated with it.

One-byte parameters have a resolution of 1°C/bit and an offset of -40°C, resulting in a measurable range of -40°C to 210°C. Temperatures outside of that range are sent as either the minimum or maximum value allowable.

Two-byte parameters have a resolution of 0.03125°C/bit and an offset of -273°C, resulting in a measurable range of -273°C to 1735°C. Temperatures outside of that range are sent as either the minimum or maximum value allowable.

When RTD Input block is associated with CAN Transmit (Chapter 1.4) or Diagnostic block (Chapter 1.3), parameters from the SPN list are loaded as default values for the block in question, therefore it is recommended to select SPNs for the RTD channels prior to adjusting Diagnostic and CAN Transmit message setpoints. If an SPN is not supported by the drop list, the user can select a zero SPN, which then allows them to define the SPN and PGN per application requirements.

“RTD Offset” setpoint allows user to define small calibration offset. Offset is defined in Ohms and added to the measured RTD resistance before conversion to Temperature.

In addition to Diagnostic Blocks (Chapter 1.3), which when associated to RTD input allow double over or under temperature detection, there is open circuit detection associated with each RTD channel. Full scale reading from an ADC channel is interpreted as an open circuit. If diagnostic message generation is enabled, by setting “**Open Circuit, Generate Diagnostic Message**” as ‘True’, diagnostic message is sent after delay time defined with “**Open Circuit Delay**” setpoint. In case channel the channel in question is associated with a CAN Transmit error indicator (0xFE, 0xFEFF, 0xFEFFFF) is used instead of measurement data. Open Circuit fault is associated with ‘*FMI 5 – Current Below Normal or Open Circuit*’ and ‘*Amber Warning Lamp*’.

The 20 Pt1000 RTD Scanner keeps a log of the last 10 scans of raw ADC measurement data. If the raw data has not changed after 10 scans, the scanner will stop broadcasting the ‘frozen’ data, and start sending the error indicator (0xFE, 0xFEFF, 0xFEFFFF) instead. No DTC is associated with this condition, so the DM11 will not be changed should this happen on one or more channels. This is a redundant safety feature, and should never occur.

ADC sample rate is 500ms per channel and total sweep time 3000ms.

SPN	Description	Size (Bytes)	PGN	Rate	Index	Priority
0	User Defined	0	0	0	0	0
52	Engine Intercooler Temperature	1	65262	1000	7	6

75	Steering Axle Temperature	1	65273	1000	1	6
79	Road Surface Temperature	2	65269	1000	7	6
90	Power Takeoff Oil Temperature	1	65264	100	1	6
105	Engine Intake Manifold 1 Temperature	1	65270	500	3	6
110	Engine Coolant Temperature	1	65262	1000	1	6
120	Hydraulic Retarded Oil Temperature	1	65275	1000	2	6
169	Cargo Ambient Temperature	2	65276	1000	5	6
170	Cab Interior Temperature	2	65269	1000	2	6
171	Ambient Air Temperature	2	65269	10000	4	6
172	Engine Air Inlet Temperature	1	65269	1000	6	6
173	Engine Exhaust Gas Temperature	2	65270	500	6	6
174	Engine Fuel Temperature 1	1	65262	1000	2	6
175	Engine Oil Temperature 1	2	65262	1000	3	6
176	Engine Turbocharger Oil Temperature	2	65262	1000	5	6
177	Transmission Oil Temperature	2	65272	1000	5	6
242	Tire Temperature	2	65268	10000	3	6
412	Engine Exhaust Gas Recirculation 1 Temperature	2	65188	1000	7	6
441	Auxiliary Temperature 1	1	65164	0	1	7
442	Auxiliary Temperature 2	1	65164	0	2	7
578	Drive Axle Temperature	1	65273	1000	3	6
1122	Engine Alternator Bearing 1 Temperature	1	65191	1000	1	7
1123	Engine Alternator Bearing 2 Temperature	1	65191	1000	2	7
1124	Engine Alternator Winding 1 Temperature	1	65191	1000	3	7
1125	Engine Alternator Winding 2 Temperature	1	65191	1000	4	7
1126	Engine Alternator Winding 3 Temperature	1	65191	1000	5	7
1131	Engine Intake Manifold 2 Temperature	1	65189	500	1	6
1132	Engine Intake Manifold 3 Temperature	1	65189	500	2	6
1133	Engine Intake Manifold 4 Temperature	1	65189	500	3	6
1135	Engine Oil Temperature 2	2	65188	1000	1	6
1136	Engine ECU Temperature	2	65188	1000	3	6
1137	Engine Exhaust Gas Port 1 Temperature	2	65187	1000	1	6
1138	Engine Exhaust Gas Port 2 Temperature	2	65187	1000	3	6
1139	Engine Exhaust Gas Port 3 Temperature	2	65187	1000	5	6
1140	Engine Exhaust Gas Port 4 Temperature	2	65187	1000	7	6
1141	Engine Exhaust Gas Port 5 Temperature	2	65186	1000	1	6
1142	Engine Exhaust Gas Port 6 Temperature	2	65186	1000	3	6
1143	Engine Exhaust Gas Port 7 Temperature	2	65186	1000	5	6
1144	Engine Exhaust Gas Port 8 Temperature	2	65186	1000	7	6
1145	Engine Exhaust Gas Port 9 Temperature	2	65185	1000	1	6
1146	Engine Exhaust Gas Port 10 Temperature	2	65185	1000	3	6
1147	Engine Exhaust Gas Port 11 Temperature	2	65185	1000	5	6
1148	Engine Exhaust Gas Port 12 Temperature	2	65185	1000	7	6
1149	Engine Exhaust Gas Port 13 Temperature	2	65184	1000	1	6
1150	Engine Exhaust Gas Port 14 Temperature	2	65184	1000	3	6
1151	Engine Exhaust Gas Port 15 Temperature	2	65184	1000	5	6
1152	Engine Exhaust Gas Port 16 Temperature	2	65184	1000	7	6
1153	Engine Exhaust Gas Port 17 Temperature	2	65183	1000	1	6

1154	Engine Exhaust Gas Port 18 Temperature	2	65183	1000	3	6
1155	Engine Exhaust Gas Port 19 Temperature	2	65183	1000	5	6
1156	Engine Exhaust Gas Port 20 Temperature	2	65183	1000	7	6
1157	Engine Main Bearing 1 Temperature	2	65182	1000	1	6
1158	Engine Main Bearing 2 Temperature	2	65182	1000	3	6
1159	Engine Main Bearing 3 Temperature	2	65182	1000	5	6
1160	Engine Main Bearing 4 Temperature	2	65182	1000	7	6
1161	Engine Main Bearing 5 Temperature	2	65181	1000	1	6
1162	Engine Main Bearing 6 Temperature	2	65181	1000	3	6
1163	Engine Main Bearing 7 Temperature	2	65181	1000	5	6
1164	Engine Main Bearing 8 Temperature	2	65181	1000	7	6
1165	Engine Main Bearing 9 Temperature	2	65180	1000	1	6
1166	Engine Main Bearing 10 Temperature	2	65180	1000	3	6
1167	Engine Main Bearing 11 Temperature	2	65180	1000	5	6
1172	Engine Turbocharger 1 Compressor Inlet Temperature	2	65178	1000	7	6
1173	Engine Turbocharger 2 Compressor Inlet Temperature	2	65178	1000	1	6
1174	Engine Turbocharger 3 Compressor Inlet Temperature	2	65178	1000	3	6
1175	Engine Turbocharger 4 Compressor Inlet Temperature	2	65178	1000	5	6
1180	Engine Turbocharger 1 Turbine Inlet Temperature	2	65176	1000	1	6
1181	Engine Turbocharger 2 Turbine Inlet Temperature	2	65176	1000	3	6
1182	Engine Turbocharger 3 Turbine Inlet Temperature	2	65176	1000	5	6
1183	Engine Turbocharger 4 Turbine Inlet Temperature	2	65176	1000	7	6
1184	Engine Turbocharger 1 Turbine Outlet Temperature	2	65175	1000	1	6
1185	Engine Turbocharger 2 Turbine Outlet Temperature	2	65175	1000	3	6
1186	Engine Turbocharger 3 Turbine Outlet Temperature	2	65175	1000	5	6
1187	Engine Turbocharger 4 Turbine Outlet Temperature	2	65175	1000	7	6
1212	Engine Auxiliary Coolant Temperature	1	65172	500	2	6
1636	Engine Intake Manifold 1 Air Temperature (High Resolution)	2	65129	1000	1	6
1637	Engine Coolant Temperature (High Resolution)	2	65129	1000	3	6
1638	Hydraulic Temperature	1	65128	1000	1	6
1687	Auxiliary Heater Outlet Coolant Temperature	1	65133	1000	1	6
1688	Auxiliary Heater Input Air Temperature	1	65133	1000	2	6
1800	Battery 1 Temperature	1	65104	1000	1	6
1801	Battery 1 Temperature	1	65104	1000	2	6
1802	Engine Intake Manifold 5 Temperature	1	65189	1000	4	6

1803	Engine Intake Manifold 6 Temperature	1	65189	500	5	6
2433	Engine Exhaust Gas Temperature - Right Manifold	2	65031	500	1	6
2434	Engine Exhaust Gas Temperature - Left Manifold	2	65031	500	3	6
2629	Engine Turbocharger 1 Compressor Outlet Temperature	2	64979	500	1	6
2630	Engine Charge Air Cooler 1 Outlet Temperature	2	65129	1000	7	6
2799	Engine Turbocharger 2 Compressor Outlet Temperature	2	64979	1000	3	6
2800	Engine Turbocharger 3 Compressor Outlet Temperature	2	64979	1000	5	6
2801	Engine Turbocharger 4 Compressor Outlet Temperature	2	64979	1000	7	6
2986	Engine Intake Valve Actuation System Oil Temperature	2	65129	1000	5	6
3031	Aftertreatment 1 SCR Catalyst Tank Temperature	1	65110	1000	2	6
3241	Aftertreatment 1 Exhaust Gas Temperature 1	2	64948	500	1	6
3242	Aftertreatment 1 Diesel Particulate Filter Intake Gas Temperature		64948	500	3	6
3245	Aftertreatment 1 Exhaust Gas Temperature 3	2	64947	500	1	6
3246	Aftertreatment 1 Diesel Particulate Filter Outlet Gas Temperature	2	64947	500	3	6
3249	Aftertreatment 1 Exhaust Gas Temperature 2	2	64946	500	1	6
3250	Aftertreatment 1 Diesel Particulate Filter Intermediate Gas Temperature	2	64946	500	3	6
3275	Aftertreatment 2 Exhaust Gas Temperature 1	2	64945	500	1	6
3276	Aftertreatment 2 Diesel Particulate Filter Intake Gas Temperature	2	64945	500	3	6
3279	Aftertreatment 2 Exhaust Gas Temperature 3	2	64944	500	1	6
3280	Aftertreatment 2 Diesel Particulate Filter Outlet Gas Temperature	2	64944	500	3	6
3283	Aftertreatment 2 Exhaust Gas Temperature 2	2	64943	500	1	6
3284	Aftertreatment 2 Diesel Particulate Filter Intermediate Gas Temperature	2	64943	500	3	6
3468	Engine Fuel Temperature 2	1	64930	500	5	4
3515	Aftertreatment 1 SCR Catalyst Reagent Temperature 2	1	64923	1000	1	6
3823	Transmission Torque Converter Oil Outlet Temperature	2	64917	1000	2	6
3831	Aftertreatment 1 Secondary Air Temperature	2	64877	500	3	6
3834	Aftertreatment 2 Secondary Air Temperature	2	64876	500	3	6
4076	Engine Coolant Temperature 2	1	64870	1000	1	6
4151	Engine Exhaust Gas Temperature Average	2	64851	500	1	5
4152	Engine Exhaust Gas Temperature Average - Bank 2	2	64851	500	3	5

4153	Engine Exhaust Gas Temperature Average - Bank 1	2	64851	500	5	5
4193	Engine Coolant Pump Outlet Temperature	1	64870	1000	2	6
4288	Engine Exhaust Valve Actuation System Oil Temperature	2	64870	1000	4	6
4289	Aftertreatment 1 Three Way Catalytic Converter Intake Gas Temperature	2	64838	500	1	6
4290	Aftertreatment 1 Three Way Catalytic Converter Outlet Gas Temperature	2	64838	500	3	6
4295	Aftertreatment 2 Three Way Catalytic Converter Intake Gas Temperature	2	64837	500	1	6
4296	Aftertreatment 2 Three Way Catalytic Converter Outlet Gas Temperature	2	64837	500	3	6
4337	Aftertreatment 1 SCR Dosing Reagent Temperature	1	64833	500	3	6
4360	Aftertreatment 1 SCR Catalyst Intake Gas Temperature	2	64830	500	1	6
4363	Aftertreatment 1 SCR Catalyst Outlet Gas Temperature	2	64830	500	4	6
4368	Aftertreatment 1 SCR Catalyst Reagent Tank 2 Temperature	1	64829	1000	2	6
4390	Aftertreatment 2 SCR Dosing Reagent Temperature	1	64827	500	3	6
4413	Aftertreatment 2 SCR Catalyst Intake Gas Temperature	2	64824	500	1	6
4415	Aftertreatment 2 SCR Catalyst Outlet Gas Temperature	2	64824	500	4	6
4420	Aftertreatment 2 SCR Catalyst Reagent Temperature 2	1	64822	1000	1	6
4427	Aftertreatment 2 SCR Catalyst Tank Temperature	1	64821	1000	2	6
4434	Aftertreatment 2 SCR Catalyst Reagent Tank 2 Temperature	1	64820	1000	2	6
4750	Engine Exhaust Gas Recirculation 1 (EGR1) Cooler Intake Temperature	2	64879	0	3	6
4753	Aftertreatment 1 Gas Oxidation Catalyst Intake Gas Temperature	2	64802	500	1	6
4754	Aftertreatment 1 Gas Oxidation Catalyst Outlet Gas Temperature	2	64802	500	3	6
4759	Aftertreatment 2 Gas Oxidation Catalyst Intake Gas Temperature	2	64801	500	1	6
4760	Aftertreatment 2 Gas Oxidation Catalyst Outlet Gas Temperature	2	64801	500	3	6
4765	Aftertreatment 1 Diesel Oxidation Catalyst Intake Gas Temperature	2	64800	500	1	6
4766	Aftertreatment 1 Diesel Oxidation Catalyst Outlet Gas Temperature	2	64800	500	3	6
4771	Aftertreatment 2 Diesel Oxidation Catalyst Intake Gas Temperature	2	64799	500	1	6

4772	Aftertreatment 2 Diesel Oxidation Catalyst Outlet Gas Temperature	2	64799	500	3	6
4809	Aftertreatment 1 Warm Up Diesel Oxidation Catalyst Intake Temperature	2	64794	500	1	6
4810	Aftertreatment 1 Warm Up Diesel Oxidation Catalyst Outlet Temperature	2	64794	500	3	6
5020	Engine Exhaust Gas Recirculation 1 (EGR1) Mixer Intake Temperature	2	64870	1000	6	6
5148	Low Voltage Disconnect Temperature	1	64769	1000	4	6
5255	Engine Exhaust Gas Recirculation 2 (EGR2) Temperature	2	64767	1000	1	6
5256	Engine Exhaust Gas Recirculation 2 (EGR2) Mixer Intake Temperature	2	64767	0	3	6
5258	Engine Exhaust Gas Recirculation 2 (EGR2) Cooler Intake Temperature	2	64766	1000	1	6
5280	Engine Charge Air Cooler 1 Precooler Intake Temperature	2	64759	1000	1	6
5281	Engine Charge Air Cooler 1 Precooler Outlet Temperature	2	64759	1000	3	6
5283	Engine Charge Air Cooler 1 Intake Temperature	2	64758	1000	1	6
5284	Engine Charge Air Cooler 1 Ambient Air Temperature	2	64758	1000	3	6
5286	Engine Charge Air Cooler 2 Precooler Intake Temperature	2	64757	1000	1	6
5287	Engine Charge Air Cooler 2 Precooler Outlet Temperature	2	64757	1000	3	6
5289	Engine Charge Air Cooler 2 Intake Temperature	2	64756	1000	1	6
5290	Engine Charge Air Cooler 2 Outlet Temperature	2	64756	1000	3	6
5291	Engine Charge Air Cooler 2 Ambient Air Temperature	2	64756	1000	5	6
5315	Aftertreatment 2 Warm Up Diesel Oxidation Catalyst Intake Temperature	2	64749	500	1	6
5316	Aftertreatment 2 Warm Up Diesel Oxidation Catalyst Outlet Temperature	2	64749	500	3	6
5456	Aftertreatment 1 Hydrocarbon Doser Intake Fuel Temperature	1	64869	500	6	6

**Table 3 – Supported Suspect Parameter Numbers**

## 1.2. Averaging

Averaging block calculates average temperature of the selected RTD channels and can be used for example to produce data for Engine Average Information message. There are three Averaging blocks with twelve selectable “**Averaging Value**” ’s, which can be selected to be any of the twelve RTD channels. When, “**Averaging Value**” is set to ‘Disabled’, the value is omitted from average calculation. New average value is calculated every 100ms. By default, Averaging 1 is set to produce average temperature of all twenty RTD channels, Averaging 2 is set to produce average temperature of RTD channels 1 to 10 and Averaging 2 is set to produce average temperature of RTD channels 11 to 20. Outputs of the Averaging blocks are associated with CAN Transmit 21 to produce PGN 64851 Engine Average Information per J1939-71, January 2009.



### 1.3. Diagnostic Function Blocks

The 20 Pt1000 RTD Scanner supports diagnostic messaging. DM1 message is a message, containing Active Diagnostic Trouble Codes (DTC) that is sent to the J1939 network in case a fault has been detected. A Diagnostic Trouble Code is defined by the J1939 standard as a four-byte value.

In addition to supporting the DM1 message, the following are supported:

SPN	Suspect Parameter Number	(user defined)
FMI	Failure Mode Identifier	(see Table 5 and Table 6)
CM	Conversion Method	(always set to 0)
OC	Occurrence Count	(number of times the fault has happened)
DM2	Previously Active Diagnostic Trouble Codes	Sent only on request
DM3	Diagnostic Data Clear/Reset of Previously Active DTCs	Done only on request
DM11	Diagnostic Data Clear/Reset for Active DTCs	Done only on request

Fault detection and reaction is a standalone functionality that can be configured to monitor and report diagnostics of various controller parameters. The 20 Pt1000 RTD Scanner supports 23 Diagnostics Definitions, each freely configurable by the user.

By default, the monitoring of operating voltage, CPU temperature and receive message timeouts is configured to diagnostics blocks 1, 2 and 3. Diagnostic blocks 4 to 23 are set to monitor RTD inputs 1 to 20 temperature, by default. In case any of these diagnostics blocks are needed for some other use, the default settings can be adjusted by the user to suit the application.

When, an RTD channel is associated with a Diagnostic Block with “Function Type to Monitor” and “Function Parameter to Monitor” setpoints, all the SPNs of the Diagnostic Block in question are initialized with the SPN of the selected SPN channel. Thus “Function Type to Monitor” and “Function Parameter to Monitor” setpoints should be set before adjusting SPNs.

There are 4 fault types that can be used, “**Minimum and maximum error**”, “**Absolute value error**”, “**State error**” and “**Double minimum and maximum error**”.

**Minimum and maximum error** has two thresholds, “MIN Shutdown” and “MAX Shutdown” that have configurable, independent diagnostics parameters (SPN, FMI, Generate DTCs, delay before flagging status). In case the parameter to monitor stays between these two thresholds, the diagnostic is not flagged.

**Absolute value error** has one configurable threshold with configurable parameters. In case the parameter to monitor stays below this threshold, the diagnostic is not flagged.

**State error** is similar to the Absolute value error, the only difference is that State error does not allow the user to specify specific threshold values; thresholds ‘1’ and ‘0’ are used instead. This is ideal for monitoring state information, such as received message timeouts.

**Double minimum and maximum error** lets user to specify four thresholds, each with independent diagnostic parameters. The diagnostic status and threshold values is determined and expected as show in Figure 2 below.

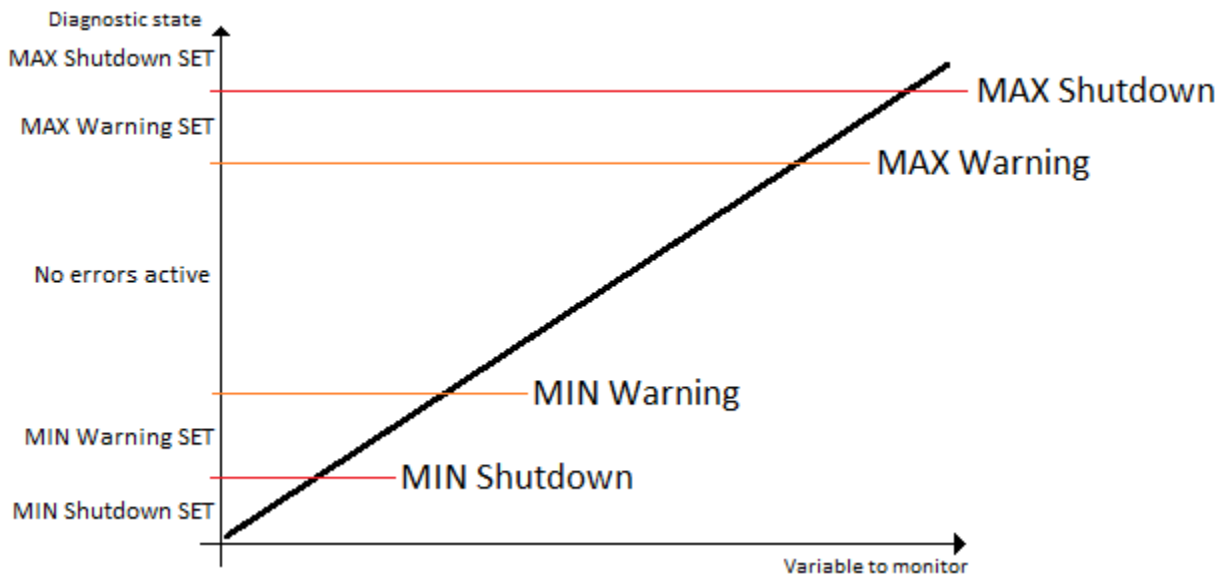

**Figure 2 – Double Minimum and Maximum Error Thresholds**

While there are no active DTCs, the 20 Pt1000 RTD Scanner will send “No Active Faults” message. If a previously inactive DTC becomes active, a DM1 will be sent immediately to reflect this. As soon as the last active DTC goes inactive, a DM1 indicating that there are no more active DTCs will be sent.

If there is more than one active DTC at any given time, the regular DM1 message will be sent using a multipacket message to the Requester Address using the Transport Protocol (TP).



At power up, the DM1 message will not be broadcasted until after 5 second delay. This is done to prevent any power up or initialization conditions from being flagged as an active error on the network.

When the fault is linked to a DTC, a non-volatile log of the occurrence count (OC) is kept. As soon as the controller detects a new (previously inactive) fault, it will start decrementing the “**Delay before Event is flagged**” timer for that Diagnostic function block. If the fault has remained present during the delay time, then the controller will set the DTC to active, and will increment the OC in the log. A DM1 will immediately be generated that includes the new DTC. The timer is provided so that intermittent faults do not overwhelm the network as the fault comes and goes, since a DM1 message would be sent every time the fault shows up or goes away.

By default, the fault flag is cleared when error condition that has caused it goes away. The DTC is made Previously Active and is it is no longer included in the DM1 message. To identify a fault having happened, even if the condition that has caused is one away, the “**Event Cleared only by DM11**” setpoint can be set to ‘True’. This configuration enables DTC to stay Active, even after the

fault flag has been cleared, and be included in DM1 message until a Diagnostic Data Clear/Reset for Active DTCs (DM11) has been requested.

As defined by J1939 Standard the first byte of the DM1 message reflects the Lamp status. **“Lamp Set by Event”** setpoint determines the lamp type set in this byte of DTC. **“Lamp Set by Event”** setpoint options are listed in Table 4. By default, the *‘Amber, Warning’* lamp is typically the one set be any active fault.

0	<i>Protect</i>
1	<i>Amber Warning</i>
2	<i>Red Stop</i>
3	<i>Malfunction</i>

**Table 4 – Lamp Set by Event in DM1 Options**

**“SPN for Event”** defines suspect parameter number used as part of DTC. The default value zero is not allowed by the standard, thus no DM will be sent unless **“SPN for Event”** in is configured to be different from zero. **It is user’s responsibility to select SPN that will not violate J1939 standard.** When the **“SPN for Event”** is changed, the OC of the associated error log is automatically reset to zero.

0	<i>Data Valid But Above Normal Operational Range - Most Severe Level</i>
1	<i>Data Valid But Below Normal Operational Range - Most Severe Level</i>
2	<i>Data Intermittent</i>
3	<i>Voltage Above Normal, Or Shorted To High Source</i>
4	<i>Voltage Below Normal, Or Shorted To Low Source</i>
5	<i>Current Below Normal Or Open Circuit</i>
6	<i>Current Above Normal Or Grounded Circuit</i>
7	<i>Mechanical Error</i>
8	<i>Abnormal Frequency Or Pulse Width Or Period</i>
9	<i>Abnormal Update Rate</i>
10	<i>Abnormal Rate Of Change</i>
11	<i>Root Cause Not Known</i>
12	<i>Bad Component</i>
13	<i>Out Of Calibration</i>
14	<i>Special Instructions</i>
15	<i>Data Valid But Above Normal Operating Range – Least Severe Level</i>
16	<i>Data Valid But Above Normal Operating Range – Moderately Severe Level</i>
17	<i>Data Valid But Below Normal Operating Range – Least Severe Level</i>
18	<i>Data Valid But Below Normal Operating Range – Moderately Severe Level</i>
19	<i>Network Error</i>
20	<i>Data Drifted High</i>
21	<i>Data Drifted Low</i>
31	<i>Condition Exists</i>

**Table 5 – FMI for Event Options**

Every fault has associated a default FMI with them. The used FMI can be configured with **“FMI for Event”** setpoint, presented in Table 5. When an FMI is selected from Low Fault FMIs in Table 6 for

a fault that can be flagged either high or low occurrence, it is recommended that the user would select the high occurrence FMI from the right column of Table 6. There is no automatic setting of High and Low FMIs in the firmware, the user can configure these freely.

Low Fault FMIs	High Fault FMIs
<i>FMI=1, Data Valid But Below Normal Operation Range – Most Severe Level</i>	<i>FMI=0, Data Valid But Above Normal Operational Range – Most Severe Level</i>
<i>FMI=4, Voltage Below Normal, Or Shorted to Low Source</i>	<i>FMI=3, Voltage Above Normal, Or Shorted To High Source</i>
<i>FMI=5, Current Below Normal Or Open Circuit</i>	<i>FMI=6, Current Above Normal Or Grounded Circuit</i>
<i>FMI=17, Data Valid But Below Normal Operating Range – Least Severe Level</i>	<i>FMI=15, Data Valid But Above Normal Operating Range – Least Severe Level</i>
<i>FMI=18, Data Valid But Below Normal Operating Level – Moderately Severe Level</i>	<i>FMI=16, Data Valid But Above Normal Operating Range – Moderately Severe Level</i>
<i>FMI=21, Data Drifted Low</i>	<i>FMI=20, Data Drifted High</i>

**Table 6 – Low Fault FMIs and corresponding High Fault FMIs**

#### 1.4. CAN Transmit Message Function Block

The CAN Transmit function block is used to send any output from another function block (i.e. RTD input, Averaging, CAN receive) to the J1939 network. The AX184200 ECU has twenty one CAN Transmit Messages and each message has four completely user defined signals. By default, CAN Transmit Messages 1 to 20 are associated with RTD inputs 1 to 20. And CAN Transmit Message 21 is set to produce PGN 64851 Engine Average message.

When, an RTD channel is associated with a CAN transmit message as Signal 1 Source with “**Control Source**” and “**Control Number**” setpoints, if SPN of the RTD channel is selected from the list of supported suspect parameter numbers Table 3, Signals 2 to 4 Source is set to 0 and CAN Transmit Message setpoints are initialized with associated parameters. Thus “**Control Source**” and “**Control Number**” setpoints should be set, before adjusting other CAN Transmit message setpoints.

Transmit Message “**Transmit PGN**”, “**Repetition Rate**”, “**Transmit Message Priority**”, “**Transmit Data Size**” and “**Transmit Message Priority**” are loaded from Table 3. Signal “**Transmit Data Resolution**”, “**Transmit Data Offset**”, “**Transmit Data Minimum**” and “**Transmit Data Maximum**” are set per “**Transmit Data Size**”: One-byte parameters have a resolution of 1°C/bit and an offset of -40°C, resulting in a measurable range of -40°C to 210°C and two-byte parameters have a resolution of 0.03125°C/bit and an offset of -273°C, resulting in a measurable range of -273°C to 1735°C.

If a fault is flagged for a CAN Transmit message source error indicator (0xFE, 0xFEFF, 0xFEFFFF) is send instead of the source data.

### 1.4.1. CAN Transmit Message Setpoints

Each CAN Transmit Message setpoint group includes setpoints that effect the whole message and are thus mutual for all signals of the message. These setpoints are presented in this section. The setpoints that configure an individual signal are presented in next section.

The “**Transmit PGN**” setpoint sets PGN used with the message. **User should be familiar with the SAE J1939 standard and select values for PGN/SPN combinations as appropriate from section J1939/71.**

“**Repetition Rate**” setpoint defines the interval used to send the message to the J1939 network. If the “**Repetition Rate**” is set to zero, the message is disabled unless it shares its PGN with another message. In case of a shared PGN repetition rate of the LOWEST numbered message are used to send the message ‘bundle’.



At power up, transmitted message will not be broadcasted until after a 5 second delay. This is done to prevent any power up or initialization conditions from creating problems on the network.

By default, all messages are sent on Proprietary B PGNs as broadcast messages. Thus “**Transmit Message Priority**” is always initialized to 6 (low priority) and the “**Destination Address**” setpoint is not used. This setpoint is only valid when a PDU1 PGN has been selected, and it can be set either to the Global Address (0xFF) for broadcasts or sent to a specific address as setup by the user.

### 1.4.2. CAN Transmit Signal Setpoints

Each CAN transmit message has four associated signals, which define data inside the Transmit message. “**Control Source**” setpoint together with “**Control Number**” setpoint define the signal source of the message. “**Control Source**” and “**Control Number**” options are listed in Table 8. Setting “**Control Source**” to ‘*Control Not Used*’ disables the signal.

“**Transmit Data Type**” setpoint options are listed in Table 7. By default, ‘*CAN signal continuous*’ is selected and signal data is presented continuous form. If ‘*CAN signal discrete*’ the signal data is considered as digital and is interpreted as 0 below “**CAN Transmit Data Maximum**”. When ‘*CAN signal undefined*’ signal data is considered undefined and all signal bits are set to 1.

0	<i>CAN signal undefined</i>
1	<i>CAN signal discrete</i>
2	<i>CAN signal continuous</i>

**Table 7 – CAN Transmit Data Type Options**

“**Transmit Data Width**” setpoint determines how many bits signal reserves from the message. “**Transmit Data Index in Array**” determines in which of 8 bytes of the CAN message LSB of the signal is located. Similarly, “**Transmit Bit Index in Byte**” determines in which of 8 bits of a byte the LSB is located. These setpoints are freely configurable, thus **it is the User’s responsibility to ensure that signals do not overlap and mask each other.**

“**Transmit Data Resolution**” setpoint determines the scaling done on the signal data before it is sent to the bus. “**Transmit Data Offset**” setpoint determines the value that is subtracted from the signal data before it is scaled. Offset and Resolution are interpreted in units of the selected source signal.

## 1.5. CAN Receive Function Block

The CAN Receive function block is designed to take any SPN from the J1939 network and use it as an input to another function block (i.e. Outputs).

The “**Receive Message Enabled**” is the most important setpoint associated with this function block and it should be selected first. Changing it will result in other setpoints being enabled/disabled as appropriate. By default, ALL receive messages are disabled.

Once a message has been enabled, a Lost Communication fault will be flagged if that message is not received off the bus within the “**Receive Message Timeout**” period. This could trigger a Lost Communication event as described in section 1.3. In order to avoid timeouts on a heavily saturated network, it is recommended to set the period at least three times longer than the expected update rate. To disable the timeout feature, simply set this value to zero, in which case the received message will never trigger a Lost Communication fault.

By default, all control messages are expected to be sent to the 20 Pt1000 RTD Scanner on Proprietary B PGNs. However, should a PDU1 message be selected, the 20 Pt1000 RTD Scanner can be setup to receive it from any ECU by setting the “**Specific Address that sends the PGN**” to the Global Address (0xFF). If a specific address is selected instead, then any other ECU data on the PGN will be ignored.

The “**Receive Data Type**”, “**Receive Data Width**”, “**Receive Data Index in Array (LSB)**”, “**Receive Bit Index in Byte (LSB)**”, “**Receive Resolution**” and “**Receive Offset**” can all be used to map any SPN supported by the J1939 standard to the output data of the Received function block.

As mentioned earlier, a CAN receive function clock can be selected as the source of the control input for the output function blocks. When this is the case, the “**Received Data Min (Off Threshold)**” and “**Received Data Max (On Threshold)**” setpoints determine the minimum and maximum values of the control signal. As the names imply, they are also used as the On/Off thresholds for digital output types. These values are in whatever units the data is AFTER the resolution and offset is applied to CAN receive signal.

20 Pt1000 RTD Scanner supports up to four unique CAN Receive Messages. Defaults setpoint values are listed in section 4.

## 1.6. Available Control Sources

Many of the Function Blocks have selectable input signals, which are determined with “[**Name**] **Source**” and “[**Name**] **Number**” setpoints. Together, these setpoints uniquely select how the I/O of the various function blocks are linked together. “[**Name**] **Source**” setpoint determines the type of the source and “[**Name**] **Number**” selects the actual source if there is more than one of the same type. Available “[**Name**] **Source**” options and associated “[**Name**] **Number**” ranges are listed in

Table 8. All sources, except “CAN message reception timeout”, are available for all blocks, including output control blocks and CAN Transmit messages. Thought input Sources are freely selectable, not all options would make sense for any particular input, and it is up to the user to program the controller in a logical and functional manner.

Sources	Number Range	Notes
0: Control Not Used	N/A	When this is selected, it disables all other setpoints associated with the signal in question.
1: Received CAN Message	1 to 4	User must enable the function block, as it is disabled by default.
2: RTD Input Measured Temperature	1 to 40	1-20 measured value in °C 21-40 measured value in °F
3: RTD Input Measured Resistance	1 to 20	Measured RTD resistance in Ohms
4: Not Available	1 to 2	
5: Averaging	1 to 3	
6: Power Supply Measured	1 (1 to 255)	1 - Measured power supply value in Volts. (Can be used to define ON limit for Diagnostic Enable Source)
7: Processor Temperature Measured	1 (1 to 255)	1 - Measured processor temperature in °C. (Can be used to define ON limit for Diagnostic Enable Source)
8: CAN Reception Timeout	1	1 - Measured power supply value in Volts. (Can be used to define ON limit for Diagnostic Enable Source)

**Table 8 – Available Control Sources and Numbers**

If a non-digital signal is selected to drive a digital input, the signal is interpreted to be OFF at or below the minimum of selected source and ON at or above the maximum of the selected source, and it will not change in between those points. Thus, analog to digital interpretation has a built-in hysteresis defined by minimum and maximum of the selected source, as shown in Figure 3.

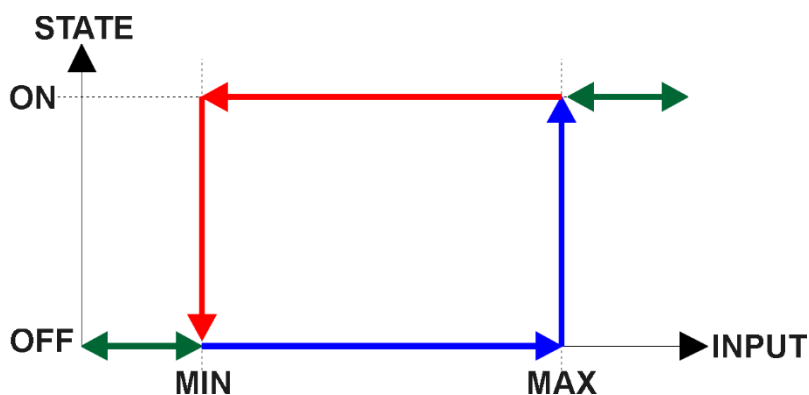

**Figure 3 – Analog source to Digital input**

## 2. INSTALLATION INSTRUCTIONS

### 2.1. Dimensions and Pinout

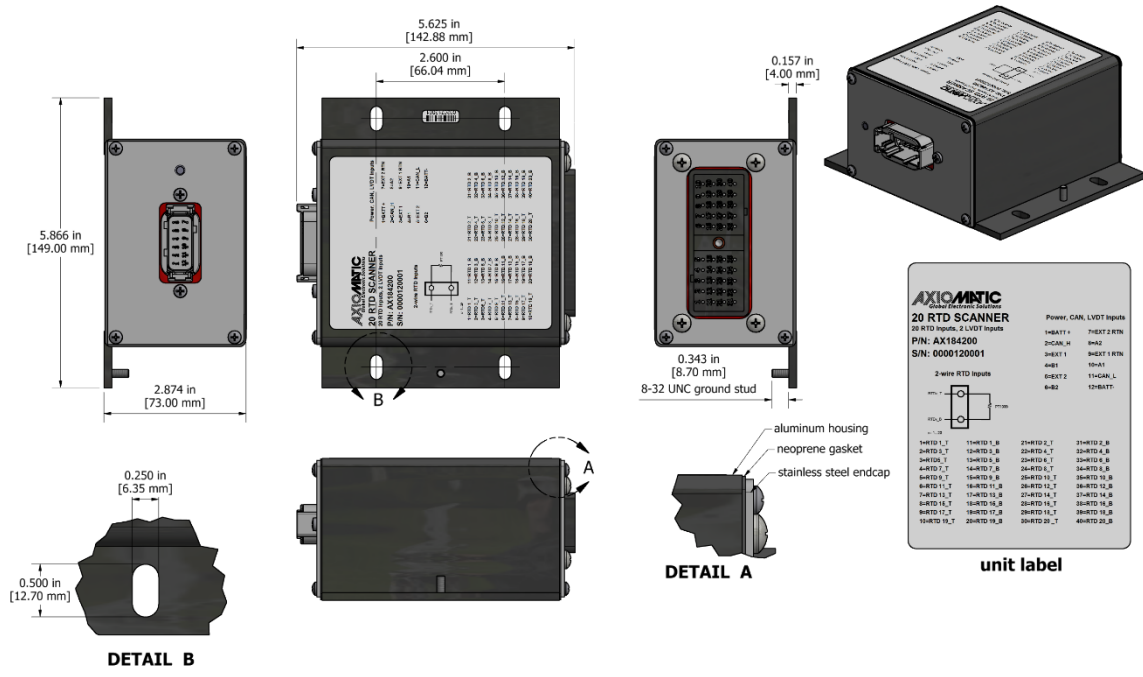
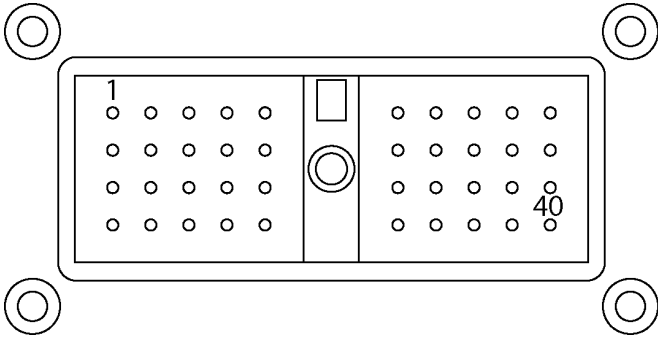

Figure 4 – AX184200 Dimensional Drawing

PIN#	Description
1	BATT +
2	CAN_H
3	Not Used
4	Not Used
5	Not Used
6	Not Used
7	Not Used
8	Not Used
9	Not Used
10	Not Used
11	CAN_L
12	BATT -

Table 9 – AX184200 DT12-12PA Connector Pinout





**Figure 5 – AX184200 DRC13-40PA Connector**

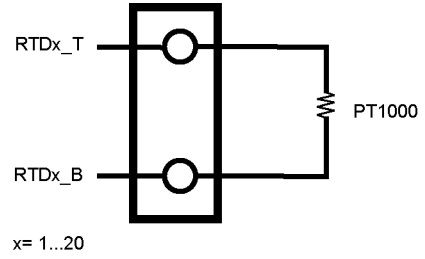

**Figure 6 – AX184200 2-wire RTD Input Wiring**

PIN#	1	2	3	4	5
Description	RTD 1 T	RTD 3 T	RTD 5 T	RTD 7 T	RTD 9 T
PIN#	11	12	13	14	15
Description	RTD 1 B	RTD 3 B	RTD 5 B	RTD 7 B	RTD 9 B
PIN#	21	22	23	24	25
Description	RTD 2 T	RTD 4 T	RTD 6 T	RTD 8 T	RTD 10 T
PIN#	31	32	33	34	35
Description	RTD 2 B	RTD 4 B	RTD 6 B	RTD 8 B	RTD 10 B

PIN#	6	7	8	9	10
Description	RTD 11 T	RTD 13 T	RTD 15 T	RTD 17 T	RTD 19 T
PIN#	16	17	18	19	20
Description	RTD 11 B	RTD 13 B	RTD 15 B	RTD 17 B	RTD 19 B
PIN#	26	27	28	29	30
Description	RTD 12 T	RTD 14 T	RTD 16 T	RTD 18 T	RTD 20 T
PIN#	36	37	38	39	40
Description	RTD 12 B	RTD 14 B	RTD 16 B	RTD 18 B	RTD 20 B

**Table 10 – AX184200 DRC13-40PB Connector Pinout**

### 3. OVERVIEW OF J1939 FEATURES

---

The software was designed to provide flexibility to the user with respect to messages sent from the ECU by providing:

- Configurable ECU Instance in the NAME (to allow multiple ECUs on the same network)
- Configurable Input Parameters
- Configurable PGN and Data Parameters
- Configurable Diagnostic Messaging Parameters, as required
- Diagnostic Log, maintained in non-volatile memory

#### 3.1. Introduction to Supported Messages

The ECU is compliant with the standard SAE J1939, and supports following PGNs from the standard.

##### From J1939-21 – Data Link Layer

- Request 59904 0x00EA00
- Acknowledgement 59392 0x00E800
- Transport Protocol – Connection Management 60416 0x00EC00
- Transport Protocol – Data Transfer Message 60160 0x00EB00
- Proprietary B from 65280 0x00FF00  
to 65535 0x00FFFF

##### From J1939-73 – Diagnostics

- DM1 – Active Diagnostic Trouble Codes 65226 0x00FECA
- DM2 – Previously Active Diagnostic Trouble Codes 65227 0x00FECB
- DM3 – Diagnostic Data Clear/Reset for Previously Active DTCs 65228 0x00FECC
- DM11 – Diagnostic Data Clear/Reset for Active DTCs 65235 0x00FED3
- DM14 – Memory Access Request 55552 0x00D900
- DM15 – Memory Access Response 55296 0x00D800
- DM16 – Binary Data Transfer 55040 0x00D700

##### From J1939-81 – Network Management

- Address Claimed/Cannot Claim 60928 0x00EE00
- Commanded Address 65240 0x00FED8

##### From J1939-71 – Vehicle Application Layer

- ECU Identification Information 64965 0x00FDC5
- Software Identification 65242 0x00FEDA
- Component Identification 65259 0x00FEEB
- All of the temperature SPNs from this section, and their corresponding PGNs

ECU Identification Information, Software Identification and Component Identification PGNs are not supported as part of the default configurations, but they can be selected as desired for transmit function blocks.

Setpoints are accessed using standard Memory Access Protocol (MAP) with proprietary addresses. The Axiomatic Electronic Assistant (EA) allows for quick and easy configuration of the unit over CAN network.

### 3.2. NAME, Address and Software ID

The 20 Pt1000 RTD Scanner ECU has the following default for the J1939 NAME. The user should refer to the SAE J1939/81 standard for more information on these parameters and their ranges.

Arbitrary Address Capable	Yes
Industry Group	5, Industrial Process Control, Stationary (Gen-Sets)
Vehicle System Instance	0
Vehicle System	0, Non-specific system
Function	128, Supplemental Engine Control Sensing
Function Instance	14, Axiomatic AX184200
ECU Instance	0, First Instance
Manufacture Code	162, Axiomatic Technologies
Identity Number	Variable, uniquely assigned during factory programming for each ECU

The ECU Instance is a configurable setpoint associated with the NAME. Changing this value will allow multiple ECUs of this type to be distinguishable from one another when they are connected on the same network.

The default value of the “ECU Address” setpoint is 235 (0xEB), Supplemental Sensor Processing Unit#1 as set by the SAE in J1939 tables B3 and B7. The EA will allow the selection of any address between 0 and 253. ***It is user’s responsibility to select an address that complies with the standard.*** The user must also be aware that since the unit is arbitrary address capable, if another ECU with a higher priority NAME contends for the selected address, The 20 Pt1000 RTD Scanner will continue select the next highest address until it finds one that it can claim. See J1939/81 for more details about address claiming.

### ECU Identification Information

PGN 64965	ECU Identification Information		-ECUID
Transmission Repetition Rate:	On request		
Data Length:	Variable		
Extended Data Page:	0		
Data Page:	0		
PDU Format:	253		
PDU Specific:	197 PGN Supporting Information:		
Default Priority:	6		
Parameter Group Number:	64965 (0x00FDC5)		
Start Position	Length	Parameter Name	SPN

a	Variable	ECU Part Number, Delimiter (ASCII "**")	2901
b	Variable	ECU Serial Number, Delimiter (ASCII "**")	2902
c	Variable	ECU Location, Delimiter (ASCII "**")	2903
d	Variable	ECU Type, Delimiter (ASCII "**")	2904
e	Variable	ECU Manufacturer Name, Delimiter (ASCII "**")	4304
(a)*(b)*(c)*(d)*(e)*			

## Software Identifier

PGN 65242		Software Identification	- SOFT
Transmission Repetition Rate:		On request	
Data Length:		Variable	
Extended Data Page:		0	
Data Page:		0	
PDU Format:		254	
PDU Specific:		218 PGN Supporting Information:	
Default Priority:		6	
Parameter Group Number:		65242 (0xFEDA)	
Start Position	Length	Parameter Name	SPN
1	1 Byte	Number of software identification fields	965
2-n	Variable	Software identification(s), Delimiter (ASCII "**")	234

Byte 1 is set to 5, and the identification fields are as follows.

**(Part Number)\*(Version)\*(Date)\*(Owner)\*(Description)**

The EA shows all this information in “General ECU Information”, as shown below.

*Note: The information provided in the Software ID is available for any J1939 service tool which supports the PGN -SOFT.*

### Component Identification

PGN 65259		Component Identification	-CI
Transmission Repetition Rate:		On request	
Data Length:		Variable	
Extended Data Page:		0	
Data Page:		0	
PDU Format:		254	
PDU Specific:		235 PGN Supporting Information:	
Default Priority:		6	
Parameter Group Number:		65259 (0x00FEED)	
Start Position	Length	Parameter Name	SPN
a	1-5 Byte	Make, Delimiter (ASCII “**”)	586
b	Variable	Model, Delimiter (ASCII “**”)	587
c	Variable	Serial Number, Delimiter (ASCII “**”)	588
d	Variable	Unit Number (Power Unit), Delimiter (ASCII “**”)	233
(a)*(b)*(c)*(d)*(e)*			

## 4. ECU SETPOINTS ACCESSED WITH AXIOMATIC ELECTRONIC ASSISTANT

This section describes in detail each setpoint, and their default and ranges. Default values presented in tables are values used when setpoint in question is active. Many of the setpoints are dependent on other setpoints and they may not be active by default. Associated Figures show screen capture of initial operation, however some of the setpoints are not in default condition as they are set differently to activate more setpoints for the image. The setpoints are divided into setpoint groups as they are shown in EA. For more information on how each setpoint is used by 20 Pt1000 RTD Scanner, refer to the relevant section in this user manual.

### 4.1. J1939 Network Parameters

“ECU Instance Number” and “ECU Address” setpoints and their effect are defined in Section 3.2.

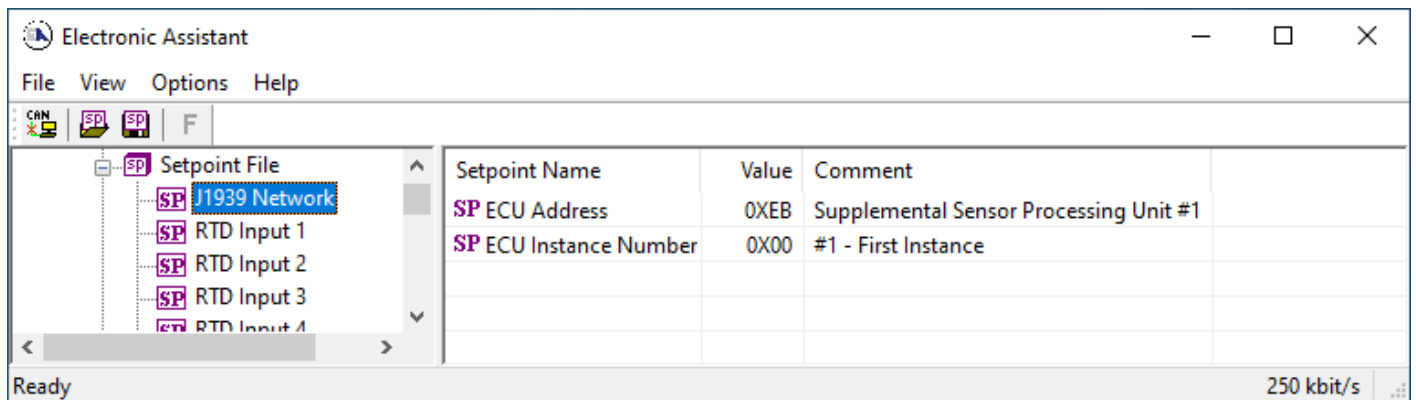

Figure 7 – Screen Capture of J1939 Setpoints

Name	Range	Default	Notes
ECU Address	0-253	0xEB	Preferred address for a self-configurable ECU
ECU Instance	0x00	0-7	Per J1939-81

Table 11 – J1939 Network Setpoints

If non-default values for the “ECU Instance Number” or “ECU Address” are used, they will be mirrored during a setpoint file flashing, and will only take effect once the entire file has been downloaded to the unit. After the setpoint flashing is complete, the unit will claim the new address and/or re-claim the address with the new NAME. If these setpoints are changing, it is recommended to close and re-open the CAN connection on EA after the file is loaded so that only the new NAME and address are showing in the J1939 CAN Network ECU list.

## 4.2. RTD Input Setpoints

The RTD Inputs are defined in Section 1.1. Please refer there for detailed information how these setpoints are used.

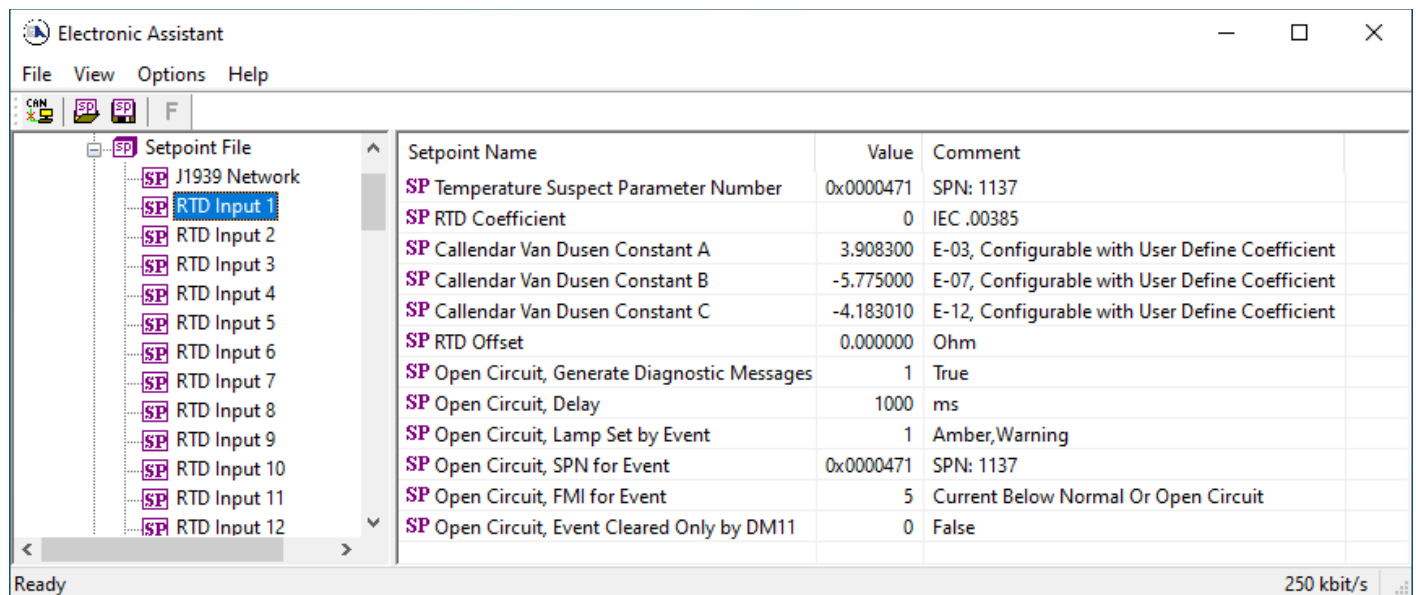

**Figure 8 – Screen Capture of RTD Input Setpoints**

Name	Range	Default	Notes
Temperature Suspect Parameter Number	Drop List	Different for each	See Table 3
RTD Coefficient	Drop List	IEC 0.00385	See Table 1
Callendar Van Dusen Constant A	-10.000000 to 10.000000 E-03	3.908300 E-03	See Table 2
Callendar Van Dusen Constant B	-10.000000 to 10.000000 E-07	-5.77500 E-07	See Table 2
Callendar Van Dusen Constant C	-10.000000 to 10.000000 E-012	-4.183010 E-012	See Table 2
RTD Offset	-10.000000 to 10.000000	0.000000 Ohm	See Section 1.1
Open Circuit, Generate Diagnostic messages	False, True	True	See Section 1.1
Open Circuit Delay	0...60000 ms	1000ms	See Section 1.1
Open Circuit, Lamp Set by Event	Drop List	Amber Warning	See Table 4
Open Circuit, SPN for Event	0...524287	Different for each	It is the user's responsibility to select an SPN that will not violate the J1939 standard.
Open Circuit, FMI for Event	Drop List	5, Current Below Normal Or Open Circuit	See Table 5
Open Circuit, Event Cleared Only by DM11	False, True	False	

**Table 12 – RTD Input Setpoints**

### 4.3. Averaging Setpoints

The Averaging function blocks are defined in Section 1.2. Please refer there for detailed information how these setpoints are used.

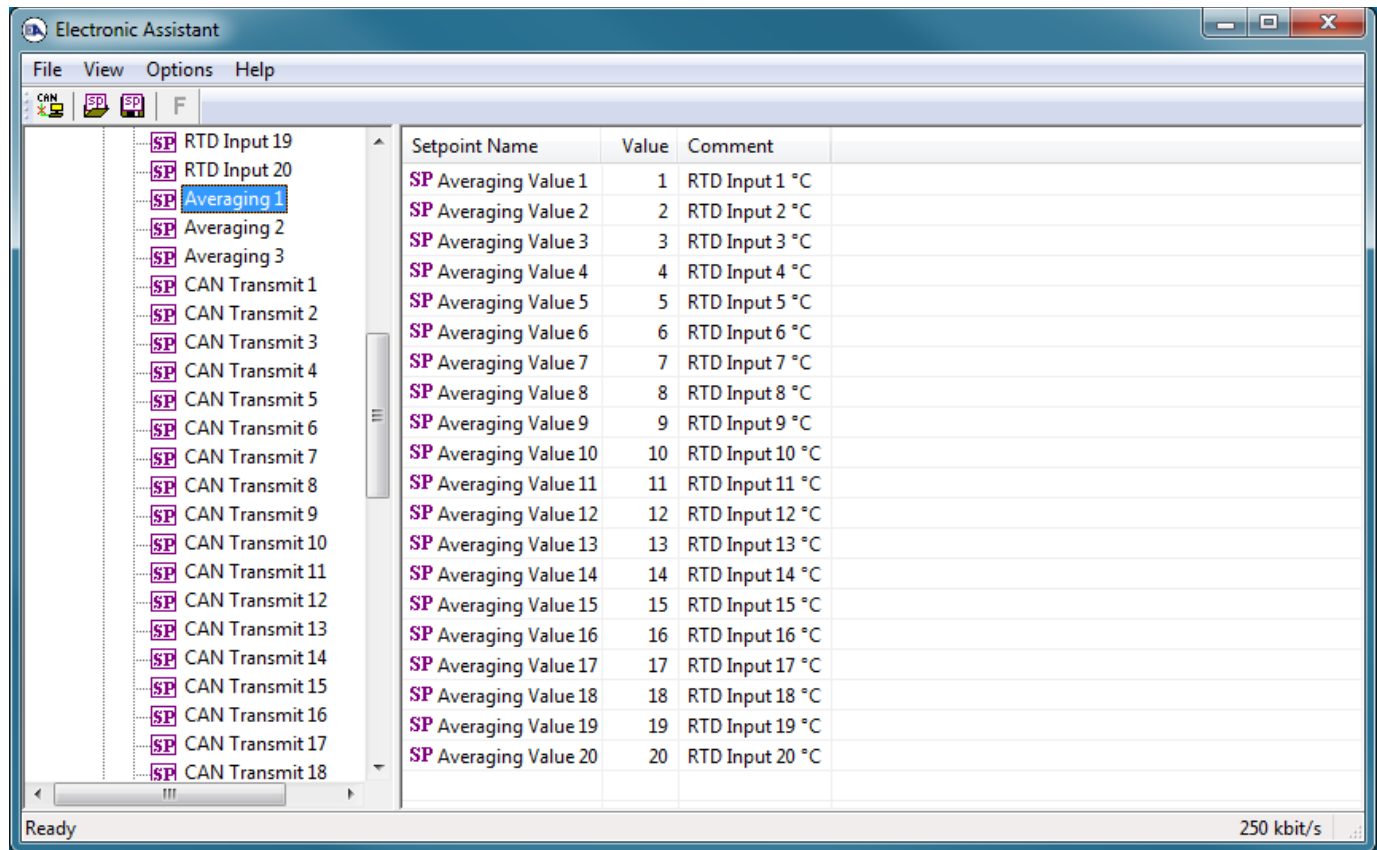

Figure 9 – Screen Capture of Averaging Setpoints

Name	Range	Default	Notes
Averaging Value 1	Drop List	RTD Input 1	
Averaging Value 2	Drop List	RTD Input 2	
Averaging Value 3	Drop List	RTD Input 3	
Averaging Value 4	Drop List	RTD Input 4	
Averaging Value 5	Drop List	RTD Input 5	
Averaging Value 6	Drop List	RTD Input 6	
Averaging Value 7	Drop List	RTD Input 7	
Averaging Value 8	Drop List	RTD Input 8	
Averaging Value 9	Drop List	RTD Input 9	
Averaging Value 10	Drop List	RTD Input 10	
Averaging Value 11	Drop List	RTD Input 11	
Averaging Value 12	Drop List	RTD Input 12	
Averaging Value 13	Drop List	RTD Input 13	
Averaging Value 14	Drop List	RTD Input 14	
Averaging Value 15	Drop List	RTD Input 15	
Averaging Value 16	Drop List	RTD Input 16	
Averaging Value 17	Drop List	RTD Input 17	
Averaging Value 18	Drop List	RTD Input 18	
Averaging Value 19	Drop List	RTD Input 19	
Averaging Value 20	Drop List	RTD Input 12	

Table 13 – Averaging Setpoints



#### **4.4. CAN Transmit Setpoints**

CAN Transmit Message Function Block is presented in Section 1.4. Please refer there for detailed information how these setpoints are used. By default, CAN Transmit Messages 1 to 20 are associated with RTD inputs 1 to 20. And CAN Transmit Message 21 is set to produce PGN 64851 Engine Average message.

Electronic Assistant

File View Options Help

CAN SP SP F

Setpoint Name	Value	Comment
SP Transmit PGN	0xFE A3	Transmit PGN: 65187
SP Transmit Repetition Rate	1000	ms
SP Transmit Message Priority	6	
SP Destination Address (PDU1)	255	Destination ECU Address: 0xFF
SP Signal 1 Data Source	2	RTD Input Measured Temperature
SP Signal 1 Data Number	1	RTD Input Measured Temperature #1 in °C
SP Signal 1 Transmit Data Type	2	CAN signal continuous
SP Signal 1 Transmit Data Width	16	
SP Signal 1 Transmit Data Index in Array (LSB)	0	1st Byte Position
SP Signal 1 Transmit Bit Index in Byte (LSB)	0	1st Bit Position
SP Signal 1 Transmit Data Resolution	0.0312500	
SP Signal 1 Transmit Data Offset	-273.0000000	
SP Signal 1 Transmit Data Minimum	-273.0000000	
SP Signal 1 Transmit Data Maximum	1735.0000000	
SP Signal 2 Data Source	0	Control Not Used
SP Signal 2 Data Number		Parameter not used with current Data Source
SP Signal 2 Transmit Data Type		Parameter not used with current Data Source
SP Signal 2 Transmit Data Width		Parameter not used with current Data Source
SP Signal 2 Transmit Data Index in Array (LSB)		Parameter not used with current Data Source
SP Signal 2 Transmit Bit Index in Byte (LSB)		Parameter not used with current Data Source
SP Signal 2 Transmit Data Resolution		Parameter not used with current Data Source
SP Signal 2 Transmit Data Offset		Parameter not used with current Data Source
SP Signal 2 Transmit Data Minimum		Parameter not used with current Data Source
SP Signal 2 Transmit Data Maximum		Parameter not used with current Data Source
SP Signal 3 Data Source	0	Control Not Used
SP Signal 3 Data Number		Parameter not used with current Data Source
SP Signal 3 Transmit Data Type		Parameter not used with current Data Source
SP Signal 3 Transmit Data Width		Parameter not used with current Data Source
SP Signal 3 Transmit Data Index in Array (LSB)		Parameter not used with current Data Source
SP Signal 3 Transmit Bit Index in Byte (LSB)		Parameter not used with current Data Source
SP Signal 3 Transmit Data Resolution		Parameter not used with current Data Source
SP Signal 3 Transmit Data Offset		Parameter not used with current Data Source
SP Signal 3 Transmit Data Minimum		Parameter not used with current Data Source
SP Signal 3 Transmit Data Maximum		Parameter not used with current Data Source
SP Signal 4 Data Source	0	Control Not Used
SP Signal 4 Data Number		Parameter not used with current Data Source
SP Signal 4 Transmit Data Type		Parameter not used with current Data Source
SP Signal 4 Transmit Data Width		Parameter not used with current Data Source
SP Signal 4 Transmit Data Index in Array (LSB)		Parameter not used with current Data Source
SP Signal 4 Transmit Bit Index in Byte (LSB)		Parameter not used with current Data Source
SP Signal 4 Transmit Data Resolution		Parameter not used with current Data Source
SP Signal 4 Transmit Data Offset		Parameter not used with current Data Source
SP Signal 4 Transmit Data Minimum		Parameter not used with current Data Source
SP Signal 4 Transmit Data Maximum		Parameter not used with current Data Source

Ready 250 kbit/s

Figure 10 – Screen Capture of CAN Transmit Message Setpoints

Name	Range	Default	Notes
Transmit PGN	0xff00 ... 0xffff	Different for each	See Section 1.4.1
Transmit Repetition Rate	0 ... 65000 ms	1000ms	0ms disables transmit
Transmit Message Priority	0...7	6	Proprietary B Priority
Destination Address	0...255	255	Not used by default
Signal 1 Control Source	Drop List	RTD Input measured	See Table 8
Signal 1 Control Number	Drop List	Different for Each	See 1.4.2
Signal 1 Transmit Data Type	Drop List	CAN signal continuous	See Table 7
Signal 1 Transmit Data Width	0-64	16	
Signal 1 Transmit Data Index in Array	0-7	Different for Each	
Signal 1 Transmit Bit Index In Byte	0-7	Different for Each	
Signal 1 Transmit Data Resolution	-100000.0 to 100000	0.03125	
Signal 1 Transmit Data Offset	-10000 to 10000	-273	
Signal 1 Transmit Data Minimum	-1000000 to Max	-273	
Signal 1 Transmit Data Maximum	Min to 100000	1735	
Signal 2 Control Source	Drop List	Signal undefined	See Table 8
Signal 2 Control Number	Drop List	Signal undefined	See 1.4.2
Signal 2 Transmit Data Type	Drop List	CAN signal continuous	See Table 7
Signal 2 Transmit Data Width	0-64	4	
Signal 2 Transmit Data Index in Array	0-7	1	
Signal 2 Transmit Bit Index In Byte	0-7	0	
Signal 2 Transmit Data Resolution	-100000.0 to 100000	0.001	
Signal 2 Transmit Data Offset	-10000 to 10000	0.0	
Signal 2 Transmit Data Minimum	-1000000 to Max	0.0	
Signal 2 Transmit Data Maximum	Min to 100000	2.5	
Signal 3 Control Source	Drop List	Signal undefined	See Table 8
Signal 3 Control Number	Drop List	Signal undefined	See 1.4.2
Signal 3 Transmit Data Type	Drop List	CAN signal continuous	See Table 7
Signal 3 Transmit Data Width	0-64	4	
Signal 3 Transmit Data Index in Array	0-7	2	
Signal 3 Transmit Bit Index In Byte	0-7	0	
Signal 3 Transmit Data Resolution	-100000.0 to 100000	0.001	
Signal 3 Transmit Data Offset	-10000 to 10000	0.0	
Signal 3 Transmit Data Minimum	-1000000 to Max	0.0	
Signal 3 Transmit Data Maximum	Min to 100000	2.5	
Signal 4 Control Source	Drop List	Signal undefined	See Table 8
Signal 4 Control Number	Drop List	Signal undefined	See 1.4.2
Signal 4 Transmit Data Type	Drop List	CAN signal continuous	See Table 7
Signal 4 Transmit Data Width	0-64	4	
Signal 4 Transmit Data Index in Array	0-7	3	
Signal 4 Transmit Bit Index In Byte	0-7	0	
Signal 4 Transmit Data Resolution	-100000.0 to 100000	0.001	
Signal 4 Transmit Data Offset	-10000 to 10000	0.0	
Signal 4 Transmit Data Minimum	-1000000 to Max	0.0	
Signal 4 Transmit Data Maximum	Min to 100000	2.5	

**Table 14 – CAN Transmit Message Setpoints**

## 4.5. CAN Receive Setpoints

The Math Function Block is defined in Section 1.5. Please refer there for detailed information about how these setpoints are used. **“Receive Message Timeout”** is set to 0ms by default. To enable Receive message set **“Receive Message Timeout”** that differs from zero.

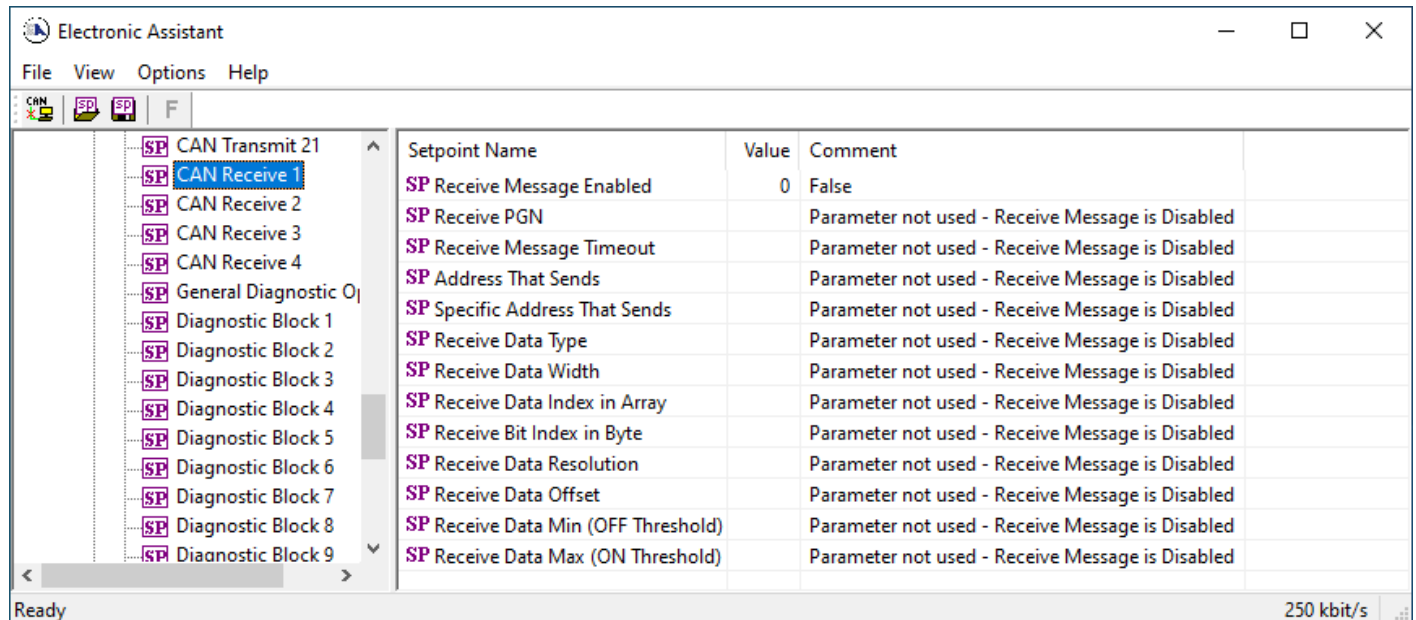

**Figure 11 – Screen Capture of CAN Receive Message Setpoints**

Name	Range	Default	Notes
Received Message Enabled	Drop List	False	
Received PGN	0 to 65536	Different for each	
Received Message Timeout	0 to 60 000 ms	0ms	
Address That Sends	Drop List	False	
Specific Address That Sends	0 to 255	0x00	
Receive Data Type	Drop List	CAN signal continuous	See Table 7
Receive Data Width	0-8	8	
Receive Data Index in Array	0-7	0	
Receive Bit Index In Byte	0-7	0	
Receive Data Resolution	-100000.0 to 100000	0.01	
Receive Data Offset	-10000 to 10000	0.0	
Receive Data Min (OFF Threshold)	-1000000 to Max	0.0	
Receive Data Max (ON Threshold)	-100000 to 100000	2.5	

**Table 15 – CAN Receive Setpoints**

## 4.6. General Diagnostics Options

Refer to section 1.3 for more info.

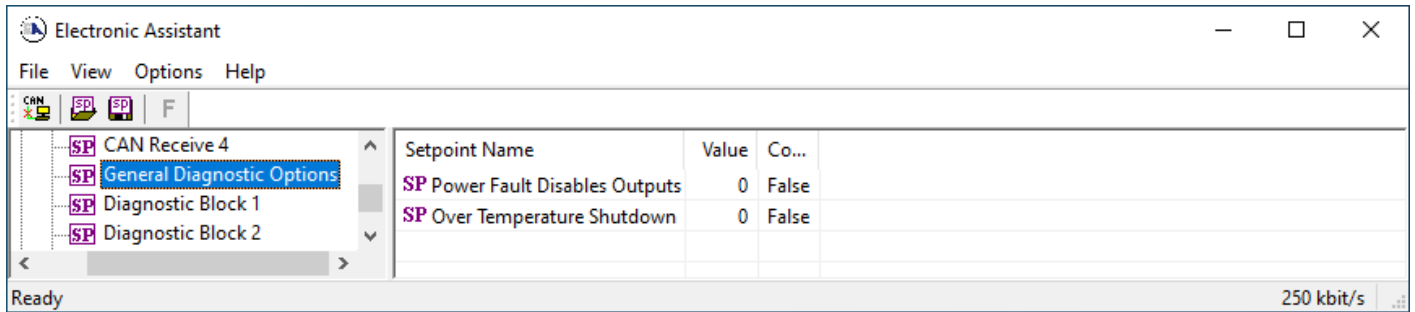

**Figure 12 – Screen Capture of General Diagnostics Options Setpoints**

Name	Range	Default	Notes
Power Fault Disables Outputs	Drop List	0	
Over Temperature Shutdown	Drop List	0	

**Table 16 – General Diagnostics Options Setpoints**

## 4.7. Diagnostics Blocks

There are 19 Diagnostics blocks that can be configured to monitor various parameters of the Controller. By default, the monitoring of operating voltage, CPU temperature and receive message timeouts is configured to diagnostics blocks 1, 2 and 3. Diagnostic blocks 4 to 15 are configured to monitor RTD inputs 1 to 12. The Diagnostic Function Block is defined in section 1.3. Please refer there for detailed information how these setpoints are used.

Setpoint Name	Value	Comment
SP Fault Detection is Enabled	1	True
SP Function Type to Monitor	2	RTD Input Measured Temperature
SP Function Parameter to Monitor	1	RTD Input Measured Temperature # #1 °C
SP Enable Source	0	Control Not Used
SP Enable Number		Parameter not used with current Enable Source selected
SP Enable Response		Parameter not used with current Enable Source selected
SP Fault Detection Type	4	Double Threshold Min and Max Error
SP Maximum Value for Diagnostic Data	2000.00	
SP Minimum Value for Diagnostic Data	-300.00	
SP Use Hysteresis When Defining Thresholds	0	False
SP Hysteresis		Parameter not used - Hysteresis not used when defining thresholds
SP Event Cleared Only by DM11	0	False
SP Set Limit for MAXIMUM SHUTDOWN	250.00	
SP Clear Limit for MAXIMUM SHUTDOWN	249.00	
SP Set Limit for MAXIMUM WARNING	125.00	
SP Clear Limit for MAXIMUM WARNING	124.00	
SP Clear Limit for MINIMUM WARNING	-19.00	
SP Set Limit for MINIMUM WARNING	-20.00	
SP Clear Limit for MINIMUM SHUTDOWN	-299.00	
SP Set Limit for MINIMUM SHUTDOWN	-300.00	
SP MAXIMUM SHUTDOWN, Event Generates a DTC in DM1	1	True
SP MAXIMUM SHUTDOWN, Lamp Set by Event	2	Red,Stop
SP MAXIMUM SHUTDOWN, SPN for Event	0x0000471	SPN: 1137
SP MAXIMUM SHUTDOWN, FMI for Event	0	Data Valid But Above Normal Operational Range - Most Severe Level
SP MAXIMUM SHUTDOWN, Delay Before Event is Flagged	5000	ms
SP MAXIMUM WARNING, Event Generates a DTC in DM1	1	True
SP MAXIMUM WARNING, Lamp Set by Event	1	Amber,Warning
SP MAXIMUM WARNING, SPN for Event	0x0000471	SPN: 1137
SP MAXIMUM WARNING, FMI for Event	15	Data Valid But Above Normal Operating Range - Least Severe Level
SP MAXIMUM WARNING, Delay Before Event is Flagged	5000	ms
SP MINIMUM WARNING, Event Generates a DTC in DM1	1	True
SP MINIMUM WARNING, Lamp Set by Event	1	Amber,Warning
SP MINIMUM WARNING, SPN for Event	0x0000471	SPN: 1137
SP MINIMUM WARNING, FMI for Event	17	Data Valid But Below Normal Operating Range - Least Severe Level
SP MINIMUM WARNING, Delay Before Event is Flagged	5000	ms
SP MINIMUM SHUTDOWN, Event Generates a DTC in DM1	0	False
SP MINIMUM SHUTDOWN, Lamp Set by Event	1	Amber,Warning
SP MINIMUM SHUTDOWN, SPN for Event	0x0000471	SPN: 1137
SP MINIMUM SHUTDOWN, FMI for Event	5	Current Below Normal Or Open Circuit
SP MINIMUM SHUTDOWN, Delay Before Event is Flagged	1000	ms

Figure 13 – Screen Capture of Diagnostic Block Setpoints

Name	Range	Default	Notes
Fault Detection is Enabled	Drop List	TRUE	
Function Type to Monitor	Drop List	2 – RTD Input Measured	See Table 8
Function parameter to Monitor	Drop List	Different for each	See Table 8
Enable Source	Drop List	0 – Control Not Used	
Enable Number	Drop List		
Enable Response	Drop List		
Fault Detection Type	Drop List	4 – Double Min and Max Error	See section 1.3
Maximum Value for Diagnostic Data	Minimum Value for Diagnostic Data ... 4.28e <sup>9</sup>	2000	
Minimum Value for Diagnostic Data	0.0 ... Maximum Value for Diagnostic Data	-3000	
Use Hysteresis When Defining Thresholds	Drop List	False	
Hysteresis	0.0 ... Maximum Value for Diagnostic Data	0.0	
Event Cleared only by DM11	Drop List	False	
Set Limit for MAXIMUM SHUTDOWN	Minimum Value for Diagnostic Data ... Maximum Value for Diagnostics Data	250	
Clear Limit for MAXIMUM SHUTDOWN	Minimum Value for Diagnostic Data ... Maximum Value for Diagnostics Data	249	
Set Limit for MAXIMUM WARNING	Minimum Value for Diagnostic Data ... Maximum Value for Diagnostics Data	125	
Clear Limit for MAXIMUM WARNING	Minimum Value for Diagnostic Data ... Maximum Value for Diagnostics Data	124	
Clear Limit for MINIMUM WARNING	Minimum Value for Diagnostic Data ... Maximum Value for Diagnostics Data	-19	
Set Limit for MINIMUM WARNING	Minimum Value for Diagnostic Data ... Maximum Value for Diagnostics Data	-20	
Clear Limit for MINIMUM SHUTDOWN	Minimum Value for Diagnostic Data ... Maximum Value for Diagnostics Data	-299	
Set Limit for MINIMUM SHUTDOWN	Minimum Value for Diagnostic Data ... Maximum Value for Diagnostics Data	-300	
MAXIMUM SHUTDOWN, Event Generates a DTC in DM1	Drop List	True	
MAXIMUM SHUTDOWN, Lamp Set by Event	Drop List	2 – Red Stop	See Table 4

MAXIMUM SHUTDOWN, SPN for Event	0...524287	Different for each 1137 (\$471)	It is the user's responsibility to select an SPN that will not violate the J1939 standard.
MAXIMUM SHUTDOWN, FMI for Event	Drop List	0 – Data Valid But Above Normal operational Range (Most Severe Level)	See Table 5
MAXIMUM SHUTDOWN, Delay Before Event is Flagged	0...60000ms	5000ms	
MAXIMUM WARNING, Event Generates a DTC in DM1	Drop List	True	
MAXIMUM WARNING, Lamp Set by Event	Drop List	1 – Amber Warning	See Table 4
MAXIMUM WARNING, SPN for Event	0...524287	Different for each 1137 (\$471)	It is the user's responsibility to select an SPN that will not violate the J1939 standard.
MAXIMUM WARNING, FMI for Event	Drop List	15 - Data Valid But Above Normal operational Range (Least Severe Level)	See Table 5
MAXIMUM WARNING, Delay Before Event is Flagged	0...60000ms	5000ms	
MINIMUM WARNING, Event Generates a DTC in DM1	Drop List	True	
MINIMUM WARNING, Lamp Set by Event	Drop List	1 – Amber Warning	See Table 4
MAXIMUM WARNING, SPN for Event	0...524287	Different for each 1137 (\$471)	It is the user's responsibility to select an SPN that will not violate the J1939 standard.
MINIMUM WARNING, FMI for Event	Drop List	17 – Data Valid But below Normal Operating Range (Least Severe Level)	See Table 5
MINIMUM WARNING, Delay Before Event is Flagged	0...60000ms	5000ms	
MINIMUM SHUTDOWN, Event Generates a DTC in DM1	Drop List	False	
MINIMUM SHUTDOWN, Lamp Set by Event	Drop List	1 - Amber Warning	See Table 4
MINIMUM SHUTDOWN, SPN for Event	0...524287	Different for each 1137 (\$471)	It is the user's responsibility to select an SPN that will not violate the J1939 standard.
MINIMUM SHUTDOWN, FMI for Event	Drop List	5, Current Below Normal Or Open Circuit	See Table 5
MINIMUM SHUTDOWN, Delay Before Event is Flagged	0...60000ms	1000ms	

**Table 17 – Diagnostic Block Setpoints**



## 5. REFLASHING OVER CAN WITH EA BOOTLOADER

The AX184200 can be upgraded with new application firmware using the **Bootloader Information** section. This section details the simple step-by-step instructions to upload new firmware provided by Axiomatic onto the unit via CAN, without requiring it to be disconnected from the J1939 network.

*Note: To upgrade the firmware use Axiomatic Electronic Assistant VX.X.XX.X or higher.*

1. When EA first connects to the ECU, the **Bootloader Information** section will display the following information.

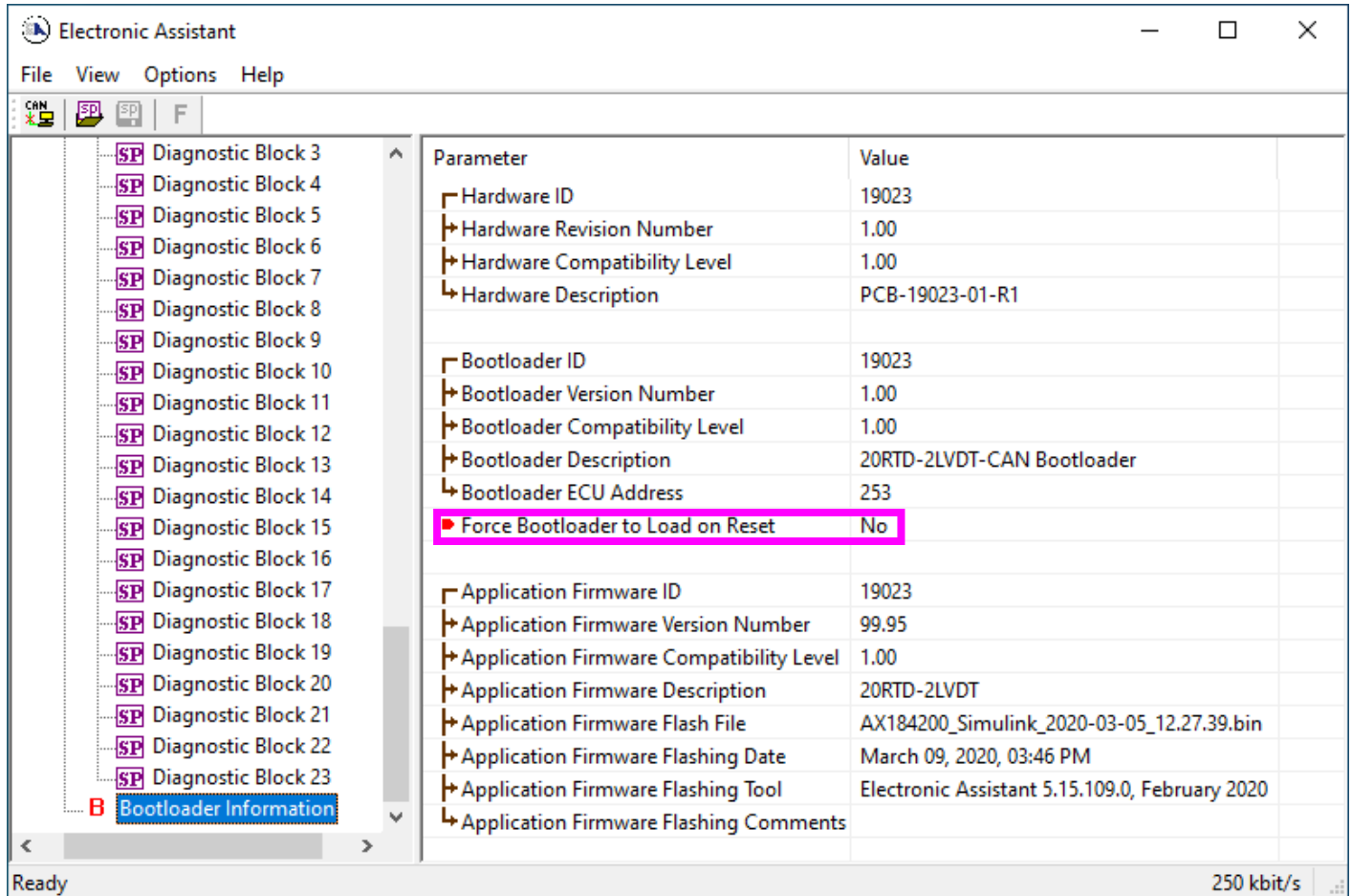

The screenshot shows the Electronic Assistant software interface. The left sidebar lists Diagnostic Blocks 3 through 23, with 'Bootloader Information' selected and highlighted in blue. The main window displays a table of parameters and their values:

Parameter	Value
Hardware ID	19023
Hardware Revision Number	1.00
Hardware Compatibility Level	1.00
Hardware Description	PCB-19023-01-R1
Bootloader ID	19023
Bootloader Version Number	1.00
Bootloader Compatibility Level	1.00
Bootloader Description	20RTD-2LVDT-CAN Bootloader
Bootloader ECU Address	253
<b>Force Bootloader to Load on Reset</b>	<b>No</b>
Application Firmware ID	19023
Application Firmware Version Number	99.95
Application Firmware Compatibility Level	1.00
Application Firmware Description	20RTD-2LVDT
Application Firmware Flash File	AX184200_Simulink_2020-03-05_12.27.39.bin
Application Firmware Flashing Date	March 09, 2020, 03:46 PM
Application Firmware Flashing Tool	Electronic Assistant 5.15.109.0, February 2020
Application Firmware Flashing Comments	

The status bar at the bottom shows 'Ready' and a data rate of '250 kbit/s'.

2. To use the bootloader to upgrade the firmware running on the ECU, change the variable “**Force Bootloader To Load on Reset**” to Yes.

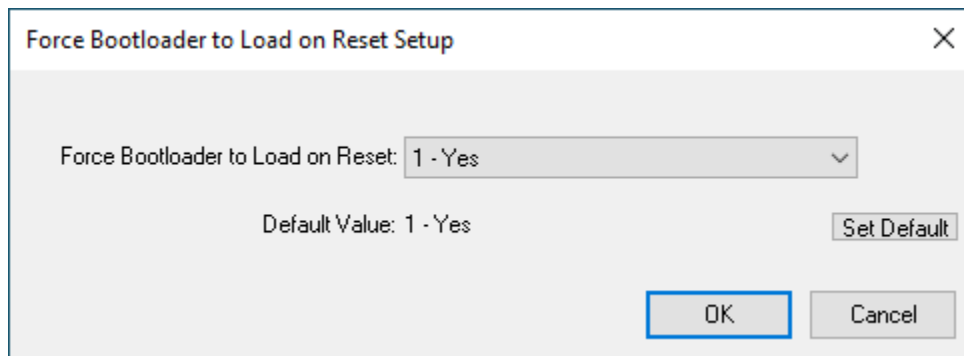

The dialog box titled 'Force Bootloader to Load on Reset Setup' contains a dropdown menu for 'Force Bootloader to Load on Reset' set to '1 - Yes'. Below the dropdown, it shows 'Default Value: 1 - Yes' and a 'Set Default' button. At the bottom, there are 'OK' and 'Cancel' buttons.

3. When the prompt box asks if you want to reset the ECU, select Yes.

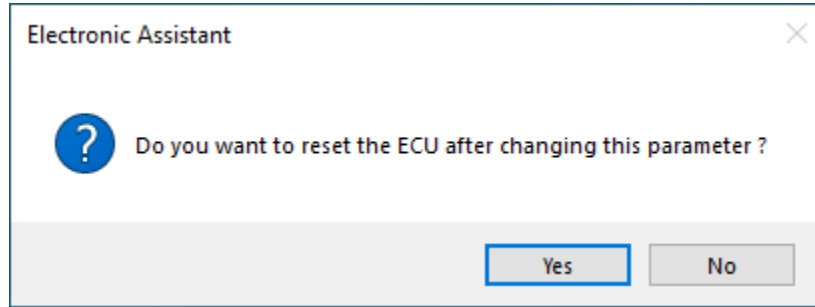

4. Upon reset, the ECU will no longer show up on the J1939 network as an AX184200 but rather as **J1939 Bootloader #1**.

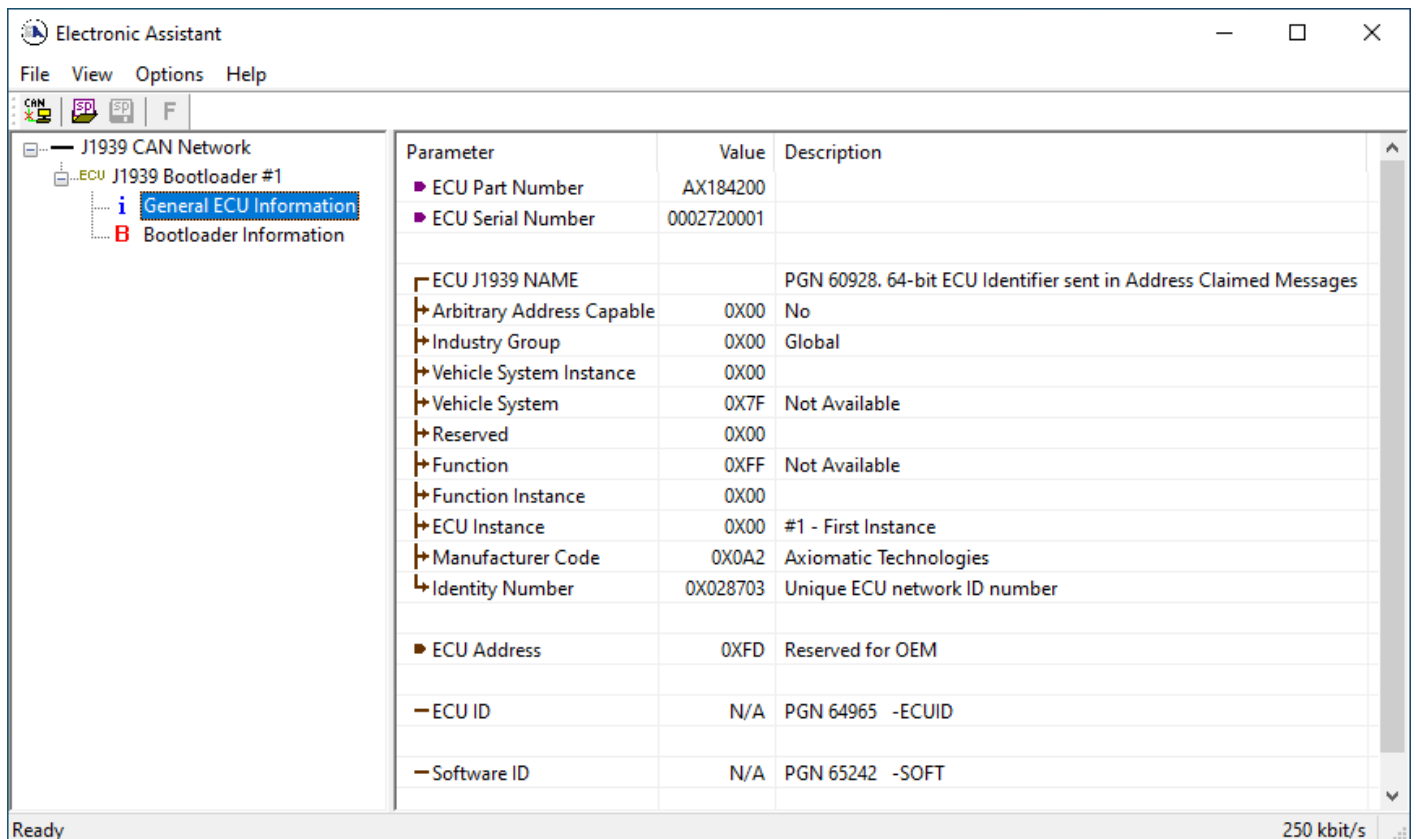
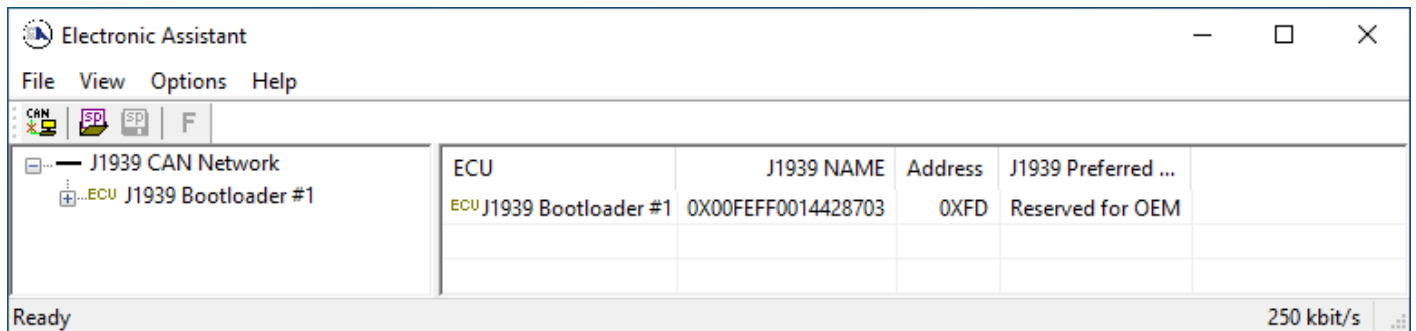

*Note that the bootloader is NOT Arbitrary Address Capable. This means that if you want to have multiple bootloaders running simultaneously (not recommended) you would have to manually*

change the address for each one before activating the next, or there will be address conflicts. And only one ECU would show up as the bootloader. Once the 'active' bootloader returns to regular functionality, the other ECU(s) would have to be power cycled to re-activate the bootloader feature.

- When the **Bootloader Information** section is selected, the same information is shown as when it was running the AX184200 firmware, but in this case the **Flashing** feature has been enabled.

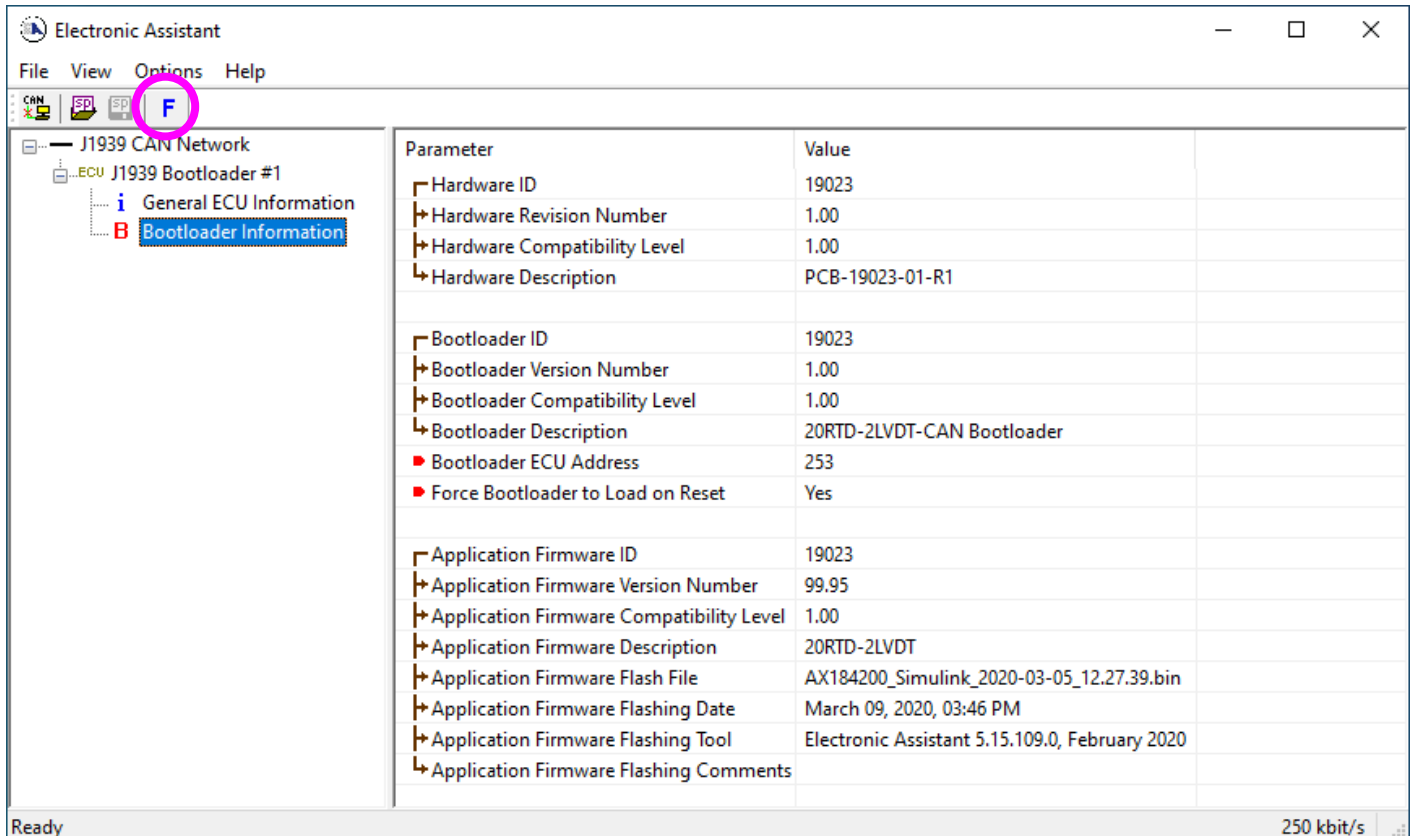

- Select the **Flashing** button and navigate to where you had saved the **AX184200\_Simulink.bin** file sent from Axiomatic. (Note: only binary (.bin) files can be flashed using the EA tool.)
- Once the Flash Application Firmware window opens, you can enter comments such as "Firmware upgraded by [Name]" if you so desire. This is not required, and you can leave the field blank if you do not want to use it.

Note: You do not have to date/time-stamp the file, as this is done automatically by the EA tool when you upload the new firmware.

Flash Application Firmware

Flash File Name: AX184200\_Simulink.bin

Flashing Comments: Firmware uploaded by Ilona Korpelainen  
Press CTRL+ENTER to add a new string

Erase All ECU Flash Memory

Flashing Status  
Idle

Flash ECU

Cancel Flashing

Exit



**WARNING:** Do not check the “Erase All ECU Flash Memory” box unless instructed to do so by your Axiomatic contact. Selecting this will erase ALL data stored in non-volatile flash including the calibration from Axiomatic factory testing. It will also erase any configuration of the setpoints that might have been done to the ECU and reset all setpoints to their factory defaults. By leaving this box unchecked, none of the setpoints will be changed when the new firmware is uploaded.

A progress bar will show how much of the firmware has been sent as the upload progresses. The more traffic there is on the J1939 network, the longer the upload process will take.

Flash Application Firmware

Flash File Name: AX184200\_Simulink.bin

Flashing Comments: Firmware uploaded by Ilona Korpelainen  
Press CTRL+ENTER to add a new string

Erase All ECU Flash Memory

Flashing Status  
Flashing Memory...

Flash ECU

Cancel Flashing

Exit

Once the firmware has finished uploading, a message will pop up indicating the successful operation. If you select to reset the ECU, the new version of the AX184200 application will start

running, and the ECU will be identified as such by EA. Otherwise, the next time the ECU is power-cycled, the AX184200 application will run rather than the bootloader function.

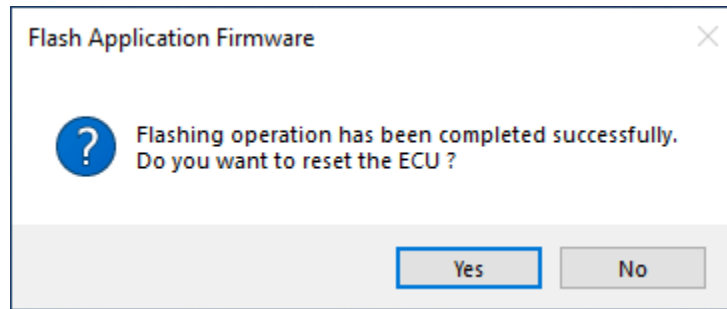

Note: If at any time during the upload the process is interrupted, the data is corrupted (bad checksum) or for any other reason the new firmware is not correct, i.e. bootloader detects that the file loaded was not designed to run on the hardware platform, the bad or corrupted application will not run. Rather, when the ECU is reset or power-cycled the **J1939 Bootloader** will continue to be the default application until valid firmware has been successfully uploaded into the unit.

## APPENDIX A - TECHNICAL SPECIFICATION

### Technical Specifications

Specifications are indicative and subject to change. Actual performance will vary depending on the application and operating conditions. Users should satisfy themselves that the product is suitable for use in the intended application. All our products carry a limited warranty against defects in material and workmanship. Please refer to our Warranty, Application Approvals/ Limitations and Return Materials Process as described on <https://www.axiomatic.com/service/>.

### Power and Protections

Power Supply Input	12/24/48 VDC nominal (8 to 65 VDC power supply range) 50 or 60 Hz is user selectable.
Quiescent Current	70 mA @ 12 VDC; 35 mA @ 24 VDC typical Inrush does not exceed 500 mA.
Protection	Reverse polarity protection is provided. Power supply input section protects against transients, surges (up to 175 V) and short circuits and is isolated from RTD inputs

### RTD Inputs

RTD Types	Up to 20 channels, independently configurable for 2-wire RTDs. Each channel operates independently.
RTD Inputs	The device accepts inputs within the following range of 200 to 4000 $\Omega$ . Accuracy: $\pm 1^{\circ}\text{C}$ with offset calibration performed at $R = 1000 \Omega$ (typical at ambient temperature) Resolution: 0.001 $^{\circ}\text{C}$ Isolation voltage is 400V.
Shield	To connect a Shield, use the grounding stud provided on the base plate.
Scan Rate	500ms per channel Total Sweep Time: 3000ms (for RTD 1-10) and 2500ms (for RTD 11-20)
Common Mode Readings	Input range 0 to $\pm 2$ VDC maximum Rejection is 115 db at 5 Vp-p (50 to 60 Hz)
Thermal Drift	40 ppm/ $^{\circ}\text{C}$ of span (maximum)
Isolation	Digital isolation is 400 VDC from input to ground. Three-way isolation is provided for the CAN line, inputs, and power supply.

### Communications

CAN	1 CAN 2.0B port, protocol SAE J1939 Passive auto-baud-rate detection. Supported options are 250 kbit/s, 500 kbit/s, and 1 Mbit/s. Digital isolation is provided for the CAN line.
Network Termination	According to the CAN standard, it is necessary to terminate the network with external termination resistors. The resistors are 120 Ohm, 0.25W minimum, metal film or similar type. They should be placed between CAN_H and CAN_L terminals at both ends of the network.

### General Specifications

Microcontroller	STM32F405RG 12-bit, 1 MB Flash Memory
Control Logic	User programmable functionality with the Axiomatic Electronic Assistant. Refer to the User Manual.
SAE J1939 Profile	For J1939 compliance (SAE, Recommended Practice for a Serial Control and Communications Vehicle Network, October 2007) all modules comply with the applicable portions of the following: SAE J1939-21, December 2006, Data Link Layer SAE J1939-71, January 2009, Vehicle Application Layer SAE J1939-73, September 2006, Application Layer – Diagnostics SAE J1939-81, May 2003, Network Management <i>Customer specific proprietary extensions can also be included in the SAE J1939 profile on request.</i>
User Interface	Axiomatic Electronic Assistant (EA) Updates for the EA are found on <a href="http://www.axiomatic.com">www.axiomatic.com</a> under the log-in tab.
Vibration	MIL-STD-202G Test 204D and 214A (Sine and Random), 10 g peak (Sine), 7.86 Grms peak (Random)
Shock	MIL-STD-202G, Test 213B, 50 g
Operating Temperature	-40 $^{\circ}\text{C}$ to 85 $^{\circ}\text{C}$ (-40 $^{\circ}\text{F}$ to 185 $^{\circ}\text{F}$ )
Storage Temperature	-50 $^{\circ}\text{C}$ to 120 $^{\circ}\text{C}$ (-58 $^{\circ}\text{F}$ to 248 $^{\circ}\text{F}$ )
Humidity	Protected against 95% humidity non-condensing, 30 $^{\circ}\text{C}$ to 60 $^{\circ}\text{C}$
Protection	IP67
Weight	2.15 lb. (0.98 kg)
Enclosure	Rugged aluminum housing, stainless steel end plates, neoprene gaskets 142.88 x 149.00 x 73.00 mm (5.63 x 5.86 x 2.87") L x W x H Connectors, Equivalent TE Deutsch P/N: 1 12-pin DTM13-12PA, 1 40-pin DRC13-40PA Can be mounted directly on the power generator set or remotely Suitable for moist, high shock, vibrating and non-hazardous environments

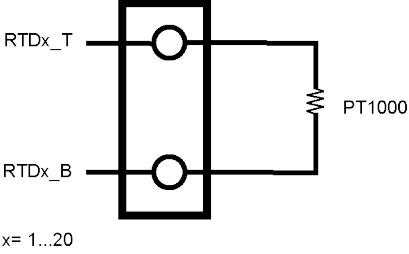
Mating Connectors	<p>Axiomatic P/N: <b>AX070210</b>  The 40 pin connector mates with TE Deutsch DRC16-40S (1) connector and 0462-201-16141 (40) SOLID CONTACT SOCKET, Nickel, SIZE 16 for 16-20 AWG wire, 13A maximum current rating. These are available by ordering AX070210.</p> <p>Axiomatic P/N: <b>PL-DTM06-12S</b>  The 12 pin connector mates with TE Deutsch DTM06-12SA (1), WM-12S (1) and 0462-201-20141 (12) SOLID CONTACT SOCKET, Nickel, SIZE 20 for 20 AWG WIRE, 7.5A maximum current rating. These are available by ordering PL-DTM06- 12S.</p>																										
Electrical Pin Out – Power, CAN	<p>1 TE Deutsch equivalent P/N: <b>DTM13-12PA</b></p> <table border="1" data-bbox="688 386 1172 793"> <thead> <tr> <th>PIN#</th> <th>Description</th> </tr> </thead> <tbody> <tr><td>1</td><td>BATT +</td></tr> <tr><td>2</td><td>CAN_H</td></tr> <tr><td>3</td><td>Not Used</td></tr> <tr><td>4</td><td>Not Used</td></tr> <tr><td>5</td><td>Not Used</td></tr> <tr><td>6</td><td>Not Used</td></tr> <tr><td>7</td><td>Not Used</td></tr> <tr><td>8</td><td>Not Used</td></tr> <tr><td>9</td><td>Not Used</td></tr> <tr><td>10</td><td>Not Used</td></tr> <tr><td>11</td><td>CAN_L</td></tr> <tr><td>12</td><td>BATT -</td></tr> </tbody> </table>	PIN#	Description	1	BATT +	2	CAN_H	3	Not Used	4	Not Used	5	Not Used	6	Not Used	7	Not Used	8	Not Used	9	Not Used	10	Not Used	11	CAN_L	12	BATT -
PIN#	Description																										
1	BATT +																										
2	CAN_H																										
3	Not Used																										
4	Not Used																										
5	Not Used																										
6	Not Used																										
7	Not Used																										
8	Not Used																										
9	Not Used																										
10	Not Used																										
11	CAN_L																										
12	BATT -																										
RTD Input Wiring	<p>2-wire RTD Input:</p>  <p>x= 1...20</p>																										

Electrical Pin Out –  
20 RTD Inputs

1 TE Deutsch Equivalent P/N: **DRC13-40PA**

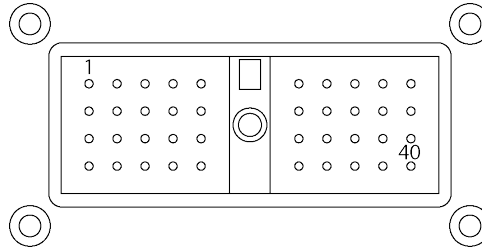

PIN#	Description
1	RTD 1 _T
2	RTD 3 _T
3	RTD 5 _T
4	RTD 7 _T
5	RTD 9 _T
6	RTD 11 _T
7	RTD 13 _T
8	RTD 15 _T
9	RTD 17 _T
10	RTD 19 _T
11	RTD 1 _B
12	RTD 3 _B
13	RTD 5 _B
14	RTD 7 _B
15	RTD 9 _B
16	RTD 11 _B
17	RTD 13 _B
18	RTD 15 _B
19	RTD 17 _B
20	RTD 19 _B
21	RTD 2 _T
22	RTD 4 _T
23	RTD 6 _T
24	RTD 8 _T
25	RTD 10 _T
26	RTD 12 _T
27	RTD 14 _T
28	RTD 16 _T
29	RTD 18 _T
30	RTD 20 _T
31	RTD 2 _B
32	RTD 4 _B
33	RTD 6 _B
34	RTD 8 _B
35	RTD 10 _B
36	RTD 12 _B
37	RTD 14 _B
38	RTD 16 _B
39	RTD 18 _B
40	RTD 20 _B



## OUR PRODUCTS

AC/DC Power Supplies  
Actuator Controls/Interfaces  
Automotive Ethernet Interfaces  
Battery Chargers  
CAN Controls, Routers, Repeaters  
CAN/WiFi, CAN/Bluetooth, Routers  
Current/Voltage/PWM Converters  
DC/DC Power Converters  
Engine Temperature Scanners  
Ethernet/CAN Converters,  
Gateways, Switches  
Fan Drive Controllers  
Gateways, CAN/Modbus, RS-232  
Gyroscopes, Inclinometers  
Hydraulic Valve Controllers  
Inclinometers, Triaxial  
I/O Controls  
LVDT Signal Converters  
Machine Controls  
Modbus, RS-422, RS-485 Controls  
Motor Controls, Inverters  
Power Supplies, DC/DC, AC/DC  
PWM Signal Converters/Isolators  
Resolver Signal Conditioners  
Service Tools  
Signal Conditioners, Converters  
Strain Gauge CAN Controls  
Surge Suppressors

## OUR COMPANY

Axiomatic provides electronic machine control components to the off-highway, commercial vehicle, electric vehicle, power generator set, material handling, renewable energy and industrial OEM markets. ***We innovate with engineered and off-the-shelf machine controls that add value for our customers.***

## QUALITY DESIGN AND MANUFACTURING

We have an ISO9001:2015 registered design/manufacturing facility in Canada.

## WARRANTY, APPLICATION APPROVALS/LIMITATIONS

Axiomatic Technologies Corporation reserves the right to make corrections, modifications, enhancements, improvements, and other changes to its products and services at any time and to discontinue any product or service without notice. Customers should obtain the latest relevant information before placing orders and should verify that such information is current and complete. Users should satisfy themselves that the product is suitable for use in the intended application. All our products carry a limited warranty against defects in material and workmanship. Please refer to our Warranty, Application Approvals/Limitations and Return Materials Process at <https://www.axiomatic.com/service/>.

## COMPLIANCE

Product compliance details can be found in the product literature and/or on [axiomatic.com](http://axiomatic.com). Any inquiries should be sent to [sales@axiomatic.com](mailto:sales@axiomatic.com).

## SAFE USE

All products should be serviced by Axiomatic. Do not open the product and perform the service yourself.



This product can expose you to chemicals which are known in the State of California, USA to cause cancer and reproductive harm. For more information go to [www.P65Warnings.ca.gov](http://www.P65Warnings.ca.gov).

## SERVICE

All products to be returned to Axiomatic require a Return Materials Authorization Number (RMA#) from [sales@axiomatic.com](mailto:sales@axiomatic.com). Please provide the following information when requesting an RMA number:

- Serial number, part number
- Runtime hours, description of problem
- Wiring set up diagram, application and other comments as needed

## DISPOSAL

Axiomatic products are electronic waste. Please follow your local environmental waste and recycling laws, regulations and policies for safe disposal or recycling of electronic waste.

## CONTACTS

**Axiomatic Technologies Corporation**  
1445 Courtneypark Drive E.  
Mississauga, ON  
CANADA L5T 2E3  
TEL: +1 905 602 9270  
FAX: +1 905 602 9279  
[www.axiomatic.com](http://www.axiomatic.com)  
[sales@axiomatic.com](mailto:sales@axiomatic.com)

**Axiomatic Technologies Oy**  
Höytämöntie 6  
33880 Lempäälä  
FINLAND  
TEL: +358 103 375 750  
[www.axiomatic.com](http://www.axiomatic.com)  
[salesfinland@axiomatic.com](mailto:salesfinland@axiomatic.com)