



USER MANUAL UMAX141121
Version 1.2

1 Universal Input, CAN RTC Controller with Dual CANopen[®]

USER MANUAL

P/N: AX141121

VERSION HISTORY

Version	Date	Author	Modification
1	November 12, 2021	Jordan Wilbur	Initial draft
1.1	July 2, 2022	Sabrina Tang	Updated dimensional drawing
1.2	January 1, 2023	M Ejaz Sue Thomas	Marketing review, legacy updates, new address Updated technical specifications

ACRONYMS

BATT +/-	Battery positive (a.k.a. Vps) or Battery Negative (a.k.a. GND)
CAN	Controller Area Network
CANopen®	CANopen® is a registered trademark of CAN in Automation e.V.
CJ	Cold Junction
COB	Communication Object
DIN	Digital Input used to measure active high or low signals
EMCY	Diagnostic Message (from CANopen® standard)
EA	Axiomatic Electronic Assistant (A Service Tool for Axiomatic ECUs)
ECU	Electronic Control Unit (from SAE J1939 standard)
GND	Ground reference (a.k.a. BATT-)
I/O	Inputs and Outputs
PWM	Pulse Width Modulation
RPM	Rotations per Minute
UIN	Universal input used to measure voltage, current, frequency or digital inputs
Vps	Voltage Power Supply (a.k.a. BATT+)
%dc	Percent Duty Cycle (Measured from a PWM input)

TABLE OF CONTENTS

1. OVERVIEW OF CONTROLLER	10
1.1. Input Function Blocks	10
1.1.1. Digital Input Modes	10
1.1.2. Analog Input Modes	14
1.2. Math Function Block	17
1.3. Programmable Logic Function Block	19
1.4. Lookup Table Function Block	23
1.4.1. X-Axis, Input Data Response	23
1.4.2. Y-Axis, Lookup Table Output	24
1.4.3. Point to Point Response	24
1.4.4. Point to Point Response	25
1.5. Miscellaneous Function Block	26
1.6. LED Control Function Block	27
1.7. Real Time Clock Function Block	28
1.7.1. RTC Actual Time and Date	28
1.7.2. RTC CANopen® TIME_OF_DAY	29
1.7.3. RTC Time Zone	29
1.7.4. RTC Time Adjust	30
1.8. Conditional Logic Function Block	30
1.9. Set-Reset Latch Function Block	31
1.10. Available Control Sources	32
2. DIMENSIONAL DRAWING	36
2.1. Dimensions and Pinout	36
3. INSTALLATION INSTRUCTIONS	37
3.1. Node ID and Baudrate	37
3.1.1. LSS Protocol to Update	37
3.1.1.1. Setting Node-ID	37
3.1.1.2. Setting Baudrate	38
3.2. Communication Objects (DS-301)	41
3.2.1. 1000h Device Type	42
3.2.2. 1001h Error Register	42
3.2.3. 1002h Manufacturer Status Object	42
3.2.4. 1003h Pre-Defined Error Field	42
3.2.5. 1010h Store Parameters	43
3.2.6. 1011h Restore Parameters	44
3.2.7. 1016h Consumer Heartbeat Time	44
3.2.8. 1017h Producer Heartbeat Time	44
3.2.9. 1018h Identity Object	44

3.2.10.	1020h Verify Configuration	44
3.2.11.	1029h Error Behavior.....	45
3.2.12.	1400h RPDO 1 Communication Parameters	45
3.2.13.	1401h RPDO 2 Communication Parameters	45
3.2.14.	1402h RPDO 3 Communication Parameters	45
3.2.15.	1403h RPDO 4 Communication Parameters	46
3.2.16.	1600h RPDO 1 Mapping Parameters.....	46
3.2.17.	1601h RPDO 2 Mapping Parameters.....	46
3.2.18.	1602h RPDO 3 Mapping Parameters.....	46
3.2.19.	1603h RPDO 4 Mapping Parameters.....	46
3.2.20.	1800h TPDO 1 Communication Parameters.....	47
3.2.21.	1801h TPDO 2 Communication Parameters.....	47
3.2.22.	1802h TPDO 3 Communication Parameters.....	47
3.2.23.	1803h TPDO 4 Communication Parameters.....	47
3.2.24.	1A00h TPDO 1 Mapping Parameters.....	47
3.2.25.	1A01h TPDO 2 Mapping Parameters.....	48
3.2.26.	1A02h TPDO 3 Mapping Parameters.....	48
3.2.27.	1A03h TPDO 4 Mapping Parameters.....	48
3.3.	Application Objects (DS-404 Inputs)	48
3.3.1.	6000h DI Read State 8 Input Lines	49
3.3.2.	6002h DI Polarity 8 Input Lines	49
3.3.3.	6110h AI Sensor Type.....	49
3.3.4.	6112h AI Operating Mode.....	49
3.3.5.	6132h AI Decimal Digits PV	49
3.3.6.	61A0h AI Filter Type	49
3.3.7.	61A1h AI Filter Constant.....	50
3.3.8.	7100h AI Input Field Value	50
3.3.9.	7120h AI Input Scaling 1 FV.....	50
3.3.10.	7121h AI Input Scaling 2 FV.....	50
3.3.11.	7122h AI Input Scaling 1 PV.....	50
3.3.12.	7123h AI Input Scaling 2 PV.....	50
3.3.13.	7130h AI Input Process Value	51
3.4.	Manufacturer Objects	51
3.4.1.	2100h AI Input Range.....	53
3.4.2.	2101h AI Number of Pulses per Revolution	53
3.4.3.	2102h AI Decimal Digits FV.....	53
3.4.4.	2103h AI Analog Filter	53
3.4.5.	2110h AI Error Detect Enable.....	53
3.4.6.	2111h AI Error Clear Hysteresis.....	53
3.4.7.	2112h AI Error Reaction Delay.....	54

3.4.8.	2020h DI Pull Up Down Mode 1 Input Line	54
3.4.9.	2030h DI Debounce Filter	54
3.4.10.	2040h DI Debouncing Time	54
3.4.11.	2060h DI Latched Enable	54
3.4.12.	2500h EC Extra Received PV	55
3.4.13.	2502h EC Decimal Digits PV	55
3.4.14.	2520h EC Scaling 1 PV	55
3.4.15.	2522h EC Scaling 2 PV	56
3.4.16.	2A00h LED Control Source	56
3.4.17.	2A01h LED Control Number	56
3.4.18.	2A02h LED Response	56
3.4.19.	2A03h LED Type	57
3.4.20.	2A04h LED Blink Rate	57
3.4.21.	2B01h RTC Time Zone	57
3.4.22.	2B02h RTC Time Adjust	57
3.4.23.	2B03h RTC Time Adjust Enable	57
3.4.24.	2B10h RTC Output PV	58
3.4.25.	2B11h RTC Output FV (CANopen® TIME_OF_DAY)	58
3.4.26.	3300h Programmable Logic Enable	58
3.4.27.	3310h Programmable Logic Selected Table	58
3.4.28.	3320h Programmable Logic Output Process Value	58
3.4.29.	3401h Prog Logic 1 Lookup Table Numbers	59
3.4.30.	3501h Prog Logic 2 Lookup Table Numbers	59
3.4.31.	3601h Prog Logic 3 Lookup Table Numbers	59
3.4.32.	3x02h Prog Logic [x-3] Function Logical Operator	59
3.4.33.	3x11h Prog Logic Block [x-3] Table 1 Condition 1	59
3.4.34.	3x12h Prog Logic Block [x-3] Table 1 Condition 2	59
3.4.35.	3x13h Prog Logic Block [x-3] Table 1 Condition 3	59
3.4.36.	3x21h Prog Logic Block [x-3] Table 2 Condition 1	59
3.4.37.	3x22h Prog Logic Block [x-3] Table 2 Condition 2	59
3.4.38.	3x23h Prog Logic Block [x-3] Table 2 Condition 3	59
3.4.39.	3x31h Prog Logic Block [x-3] Table 3 Condition 1	60
3.4.40.	3x32h Prog Logic Block [x-3] Table 3 Condition 2	60
3.4.41.	3x33h Prog Logic Block [x-3] Table 3 Condition 3	60
3.4.42.	3yz0h Lookup Table [yz] Input X-Axis Source	60
3.4.43.	3yz1h Lookup Table [yz] Input X-Axis Number	60
3.4.44.	3yz2h Lookup Table [yz] Auto Repeat	60
3.4.45.	3yz3h Lookup Table [yz] X-Axis Decimal Digits PV	61
3.4.46.	3yz4h Lookup Table [yz] Y-Axis Decimal Digits PV	61
3.4.47.	3yz5h Lookup Table [yz] Point Response	61

3.4.48.	3yz6h Lookup Table [yz] Point X-Axis PV	61
3.4.49.	3yz7h Lookup Table [yz] Point Y-Axis PV	62
3.4.50.	3yz8h Lookup Table [yz] Output Y-Axis PV.....	62
3.4.51.	4000h Math Block Enabled.....	62
3.4.52.	4021h Math Scaling 1 PV (Output Limit Min)	62
3.4.53.	4023h Math Scaling 2 PV (Output Limit Max)	63
3.4.54.	4030h Math Output PV	63
3.4.55.	4032h Math Decimal Digits PV	63
3.4.56.	4x00h Math [x] Input Source.....	63
3.4.57.	4x01h Math [x] Input Number	64
3.4.58.	4x03h Math [x] Decimal Digits FV	64
3.4.59.	4x20h Math [x] Scaling 1 FV.....	64
3.4.60.	4x22h Math [x] Scaling 2 FV.....	64
3.4.61.	4x40h Math [x] Input Gain.....	64
3.4.62.	4x50h Math [x] Operator	65
3.4.63.	4B00h Conditional Logic Block Enable.....	65
3.4.64.	4B01h Conditional Logic Block Result Operator	65
3.4.65.	4B10h Conditional Logic Block Output Process Value.....	65
3.4.66.	4Bxyh Conditional Logic Block [x] Condition [y] Parameters.....	66
3.4.67.	3900h Set-Reset Latch Enable.....	66
3.4.68.	3910h Set-Reset Latch Output PV	66
3.4.69.	39x1h SR Latch [X] Reset Signal Source	66
3.4.70.	39x2h SR Latch [X] Reset Signal Number	66
3.4.71.	39x3h SR Latch [X] Reset Signal OFF Threshold	67
3.4.72.	39x4h SR Latch [X] Reset Signal ON Threshold.....	67
3.4.73.	39x5h SR Latch [X] Set Signal Source.....	67
3.4.74.	39x6h SR Latch [X] Set Signal Number	67
3.4.75.	39x7h SR Latch [X] Set Signal OFF Threshold	67
3.4.76.	39x8h SR Latch [X] Set Signal ON Threshold.....	68
3.4.77.	5010h Constant Field Value	68
3.4.78.	5020h Power Supply FV	68
3.4.79.	5030h CPU Temperature FV	68
3.4.80.	5500h SPP Command.....	69
3.4.81.	5510h SPP Response	69
3.4.82.	5550h Enable Auto Updates.....	69
3.4.83.	5555h Start In Operational Mode	69
3.4.84.	55AAh Start Bootloader	69
3.4.85.	5B50h Change Baud Rate.....	70
3.4.86.	5B51h Change Node ID.....	70

APPENDIX A - TECHNICAL SPECIFICATION.....A-1

Table 1 – DI Pullup/Down Options	11
Table 2 – Object 6002h DI Polarity 8 Input Lines Options	11
Table 3 – Object 2060h DI Latched Logic Enabled	12
Table 4 – Digital Input Logic Combinations	12
Table 5 – Object 6112h - AI Operating Mode Options	14
Table 6 – Object 6110h AI Sensor Type Options	14
Table 7 – AI Input Range Options Depending on Sensor Type	15
Table 8 – Object 2103h – Analog Input Filter	15
Table 9 – Object 2030h – PWM Debounce Filter	16
Table 10 – Object 61A0h - AI Filter Type Options.....	16
Table 11 – Math Function Options	17
Table 12 – Logic Block [x-3] Condition Structure Definition	22
Table 13 – Object 3xyzh Operator Options	22
Table 14 – Object 3[x]02h Logic Block [x-3] Logical Operator Options.....	23
Table 15 – Object 3yz5 Subindex 1: X-Axis Type Options	23
Table 16 – Object 3yz5 Subindex 2 through 11: Response	25
Table 17 – Object 5010h Constant Value Defaults	27
Table 18 – Object 2A02 LED Response	28
Table 19 – Object 2A01 LED Types	28
Table 20 – Object 2B11 Output FV	29
Table 21 – Object 2B01 RTC Time Zones	30
Table 22 – Input Operator Options	31
Table 23 – Condition Operator Options.....	31
Table 24 – Set-Reset Function Block Operation	32
Table 25 – Available Control Sources and Numbers	33
Table 26 – Control Source Objects Depending on Source Selected	34
Table 27 – Scaling Limits per Control Source	35
Table 28 – AX141121 Connector Pinout.....	36
Table 29 – LSS Baudrate Indices.....	39
Table 30 – Pre-Defined Error Field Codes	43

Figure 1 – AX141121 Block Diagram 10

Figure 2 – Digital Input Objects 11

Figure 3 – Discrete Input Hysteresis 11

Figure 4 – Digital Input Debounce Time 13

Figure 5 – Analog Input Reads as Digital 13

Figure 6 – Analog Input Objects 14

Figure 7 – Control Logic block diagram 17

Figure 8 – Programmable Logic Block Objects 19

Figure 9 – Logic Block Flow Chart 21

Figure 10 – Lookup Table Default Ramp and Step Responses 25

Figure 11 – Miscellaneous Objects 26

Figure 12 – Conditional Block Diagram 31

Figure 13 – AX141121 Dimensional Drawing 36

1. OVERVIEW OF CONTROLLER

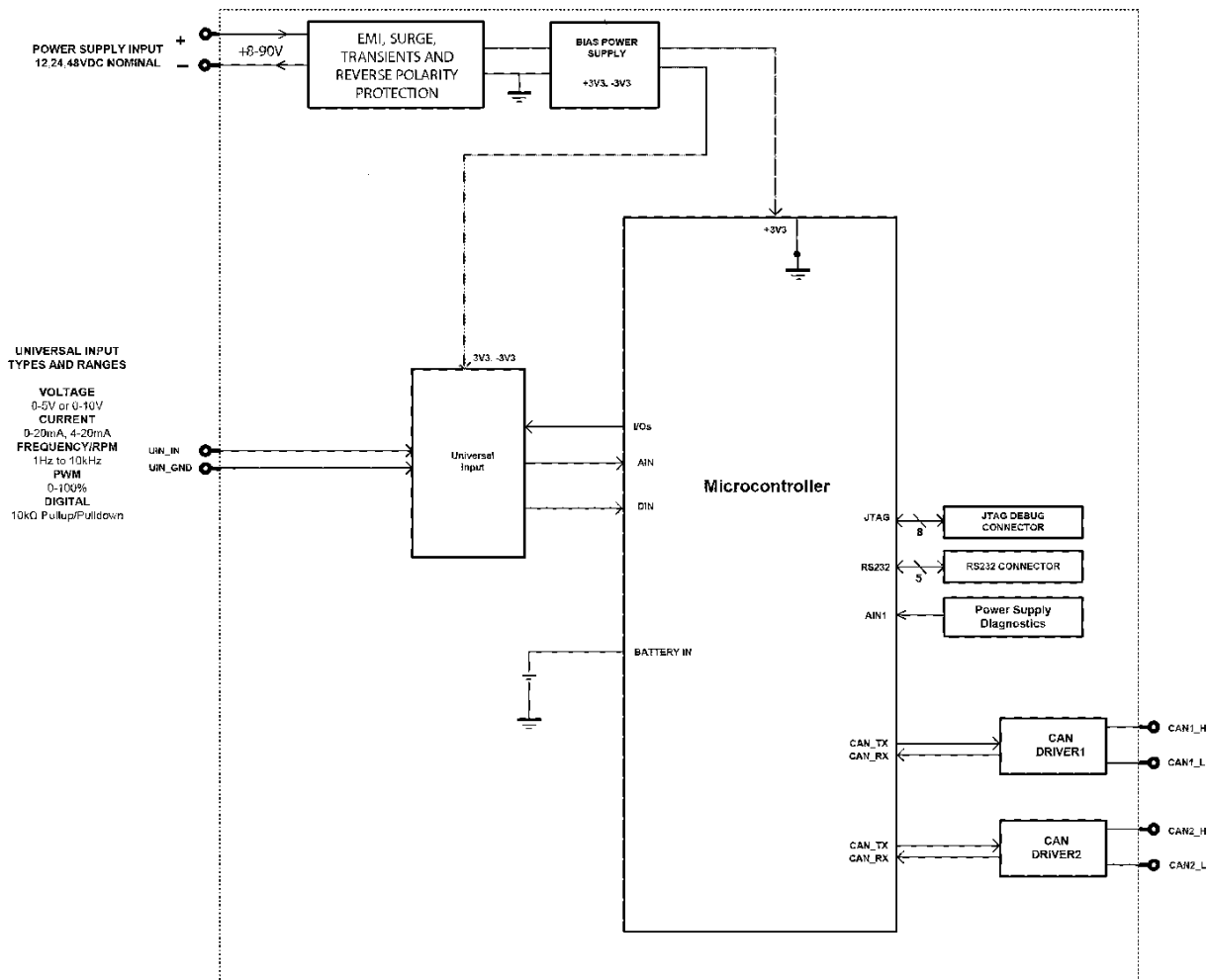

Proj 20018

Block Diagram

Sep 16, 2020

1 of 1

Drawn by T.M.

Figure 1 – AX141121 Block Diagram

The 1TC-2UIN-CO electronic control unit (ECU) is designed to provide a simple interface for Real Time Clock and 1 Universal Input over a dual CANopen® Network, to be used in an industrial environment. The hardware supports 1 Real Time Clock, and 1 Universal Input. The universal input accepts voltage, current, frequency, PWM duty cycle, and discrete voltage levels.

All CANopen® objects supported by the AX141121 are user configurable using standard commercially available tools that can interact with a CANopen® Object Dictionary via an .EDS file.

1.1. Input Function Blocks

1.1.1. Digital Input Modes

The digital input (DI) function block only becomes applicable on the input when object 6112h **AI Operation**, is set to a digital input response.

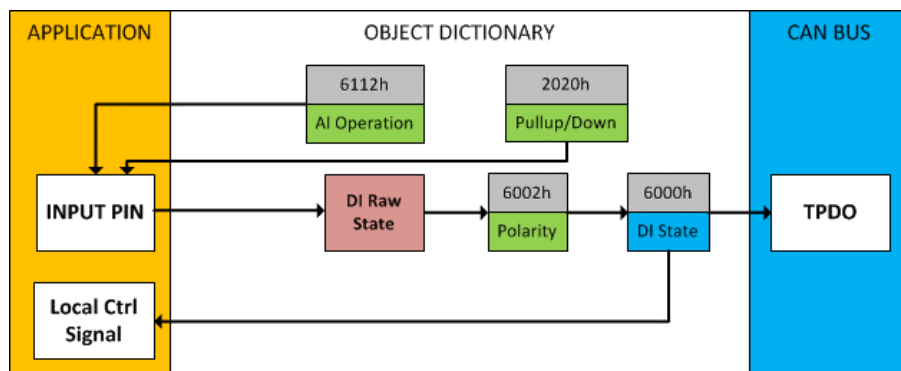

Figure 2 – Digital Input Objects

When object 6112h is set to 10 = *Digital Input*, object 2020h **DI Pull-up/Pull-down Mode** will determine the configuration of the internal Pull-up/Pull-down resistors. The options for object 2020h are shown in Table 1, with the default bolded.

Value	Meaning
0	Pullup/Down Disabled (high impedance input)
1	10kΩ Pullup Resistor Enabled
2	10kΩ Pulldown Resistor Enabled

Table 1 – DI Pullup/Down Options

Figure 3 shows the hysteresis on the input when switching a discrete signal. A digital input can be switched up to +Vcc.

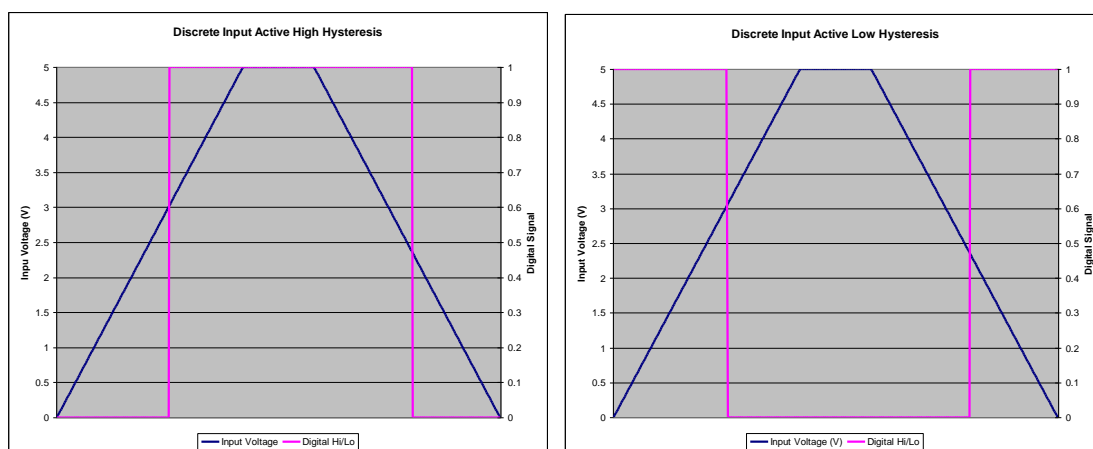

Figure 3 – Discrete Input Hysteresis

Once the raw state has been evaluated, the logical state of the input is determined by object 6002h **DI_Polarity_8_Input_Lines**. The options for object 6002h are shown in Table 2. The state of the DI will be written to read-only object 6000h **DI_Read_state_8_Input_Lines**. By default, normal on/off logic is used.

Value	Meaning
0	Normal On/Off
1	Inverse On/Off

Table 2 – Object 6002h DI Polarity 8 Input Lines Options

The format to write to object 6002h is as follows:

Sub-index 1 will determine the following inputs polarities.

Bit 7	Bit 6	Bit 5	Bit 4	Bit 3	Bit 2	Bit 1	Bit 0
-	-	-	-	UI4	UI3	UI2	UI1

The rest of the bits in sub-index 1 will be ignored.

As per the format of object 6002h, the bits in object 6000h **DI_Read_state_8_Input_Lines** will be written to represent the same inputs' states.

In addition to Object 6002h determining the Polarity, the manufacturer object 2060h determines if the Digital Input is configured for Latched Logic. The options for object 2060h are shown in Table 3. By default, the input is configured for normal logic.

Value	Meaning
0	Normal Logic
1	Latched Logic

Table 3 – Object 2060h DI Latched Logic Enabled

Using Objects 6002h and 2060h, there are four possible combinations:

6002h Value	2060h Value	Meaning
0	0	Normal Logic
1	0	Inverse Logic
0	1	Latched Logic
1	1	Inverse Latched Logic

Table 4 – Digital Input Logic Combinations

In *Normal Logic* mode, the input state is 1 when the input signal is interpreted as ON. The input state turns 0 if the input signal is interpreted as OFF.

For the *Inverse Logic* type, the opposite behavior applies. If the input signal is ON, the state turns 0 and if the input signal is OFF, the state turns 1.

Setting the Input to *Latched Logic*, the input state is toggled between 1 and 0 every time the input signal of the respective digital input changes from OFF to ON.

In *Inverse Latched Logic* mode, the opposite behavior applies. The input state toggles between 1 and 0 every time the input signal changes from ON to OFF.

The input states are sampled every 1ms. If debouncing is required, it is set by the *Discrete Input Debounce Time* configuration object 2040h. If the *Discrete Input Debounce Time* is zero, the discrete voltage level input is not debounced. By default, the *Discrete Input Debounce Time* for each input is set to 10 milliseconds.

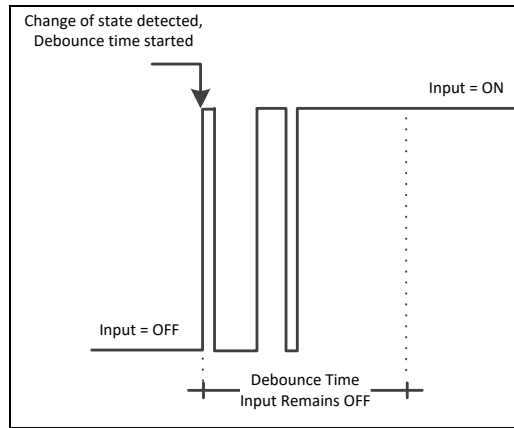

Figure 4 – Digital Input Debounce Time

There is another type of ‘digital’ input that can be selected when 6112h is set to 20 = Analog On/Off. However, in this case, the input is still configured as an analog input, and therefore the objects from the Analog Input (AI) block are applied instead of those discussed above. Here, objects 2020h, 2030h and 6030h are ignored, and 6000h is written as per the logic shown in Figure 5. In this case, the MIN parameter is set by object 7120h **AI Scaling 1 FV**, and the MAX is set by 7122h **AI Scaling 2 FV**. For all other operating modes, object 6000h will always be zero.

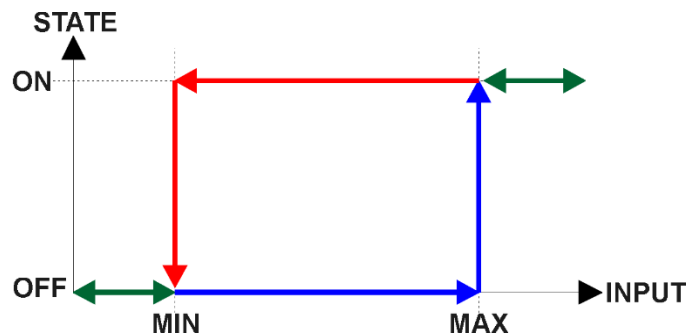

Figure 5 – Analog Input Reads as Digital

Universal Inputs can accept discrete voltage levels. The user should specify the input polarity using object 6002h **DI Polarity Bitmap** and define whether the pull-up/pull-down resistor is necessary on the input (Object 2020h **DI Pull Up Down Mode**).

When the “10kOhm Pull-Up” is selected, the pull-up resistor is connected to the internal power supply.

1.1.2. Analog Input Modes

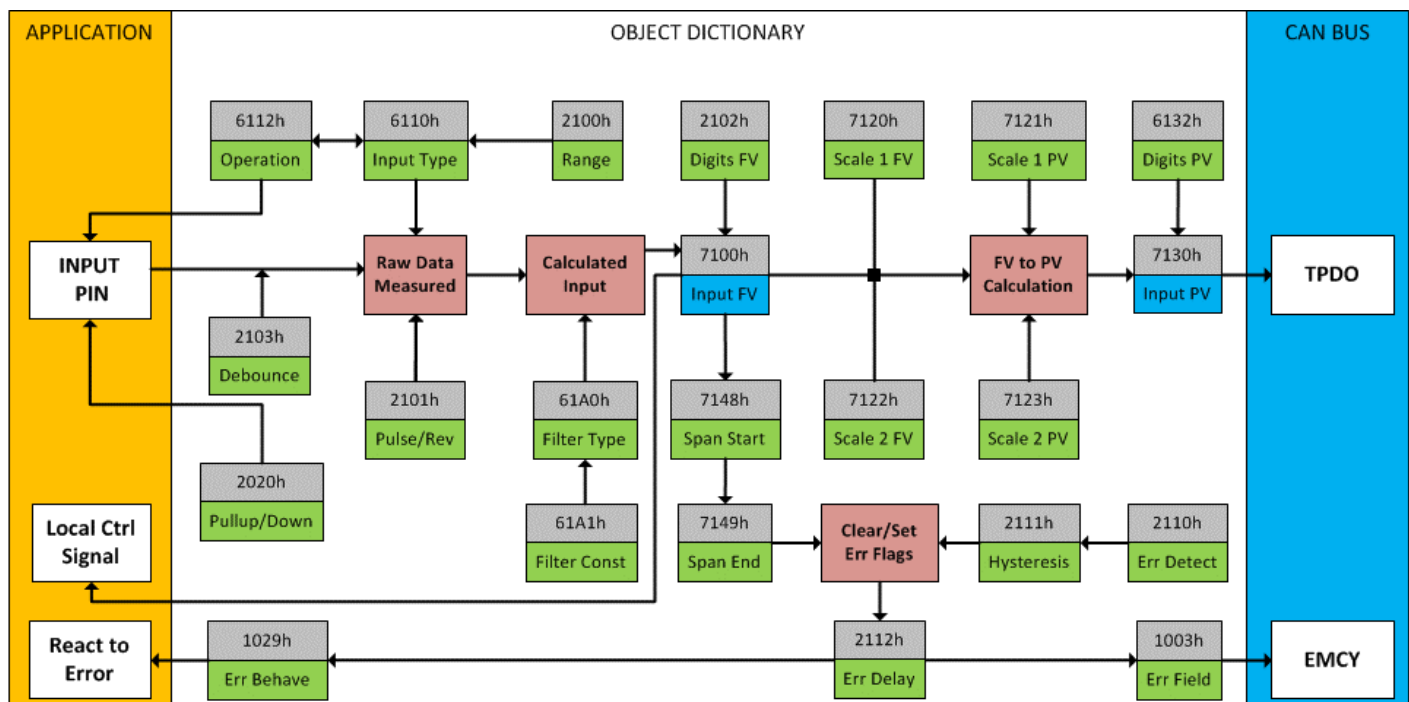

Figure 6 – Analog Input Objects

Object 6112h **AI Operating Mode** determines whether the AI or DI block is associated with an input. The options for object 6112h are shown in Table 5. No values other than what are shown here will be accepted.

Value	Meaning
0	Channel Off
1	Normal Operation (analog)
10	Digital Input (on/off)
20	Analog and On/Off

Table 5 – Object 6112h - AI Operating Mode Options

The most important object associated with the AI function block is object 6110h **AI Sensor Type**. By changing this value, and associated with its object 2100h **AI Input Range**, other objects will be automatically updated by the controller. The options for object 6110h are shown in Table 6, and no values other than what are shown here will be accepted.

Value	Meaning
40	Voltage Input
50	Current Input
60	Frequency Input (or RPM)
10000	PWM Input

Table 6 – Object 6110h AI Sensor Type Options

The allowable ranges will depend on the input sensor type selected. Table 7 shows the relationship between the sensor type, and the associated range options. The default value for each range is bolded, and object 2100h **AI Range** will automatically be updated with this value when 6110h is

changed. The grayed cells mean that the associate value is not allowed for the range object when that sensor type has been selected.

Value	Voltage	Current	Frequency	PWM
0	0 to 5V	0 to 20mA	1Hz to 10kHz	1Hz to 25kHz 0 – 100% Duty Cycle
1	0 to 10V	4 to 20mA		

Table 7 – AI Input Range Options Depending on Sensor Type

Object 2103 contains the **Analog Filter** parameter and is only applicable when measuring voltage or current. This filter is designed to suppress noise from industrial offline voltages. Object 2103h is set for 50Hz noise rejection by default.

Value	Meaning
0	Input Filter Off
1	Filter 50Hz
2	Filter 60Hz
3	Filter 50Hz and 60Hz

Table 8 – Object 2103h – Analog Input Filter

Objects 2020h **DI Pull-up/Pull-down Mode** and 2101h **AI Number of Pulses per Revolution** are used with frequency and PWM sensor types.

Object 2020h **DI Pull-up/Pull-down Mode** will determine the configuration of the internal Pull-up/Pull-down resistors. The options for object 2020h are shown in Table 1, with the default bolded.

Frequency measurement can be changed to RPM, by setting object 2101h **AI Number of Pulses per Revolution** to a non-zero value.

All inputs can be further filtered once the raw data has been measured. Object 61A0h **AI Filter Type** determines what kind of filter is used per Table 10. By default, additional software filtering is disabled.

If the Input is configured as either a Frequency Input or a PWM Input, then the following parameters become available.

The **PWM Debounce Filter** is applied to the input before the state is read by the processor. The options for this object are shown in Table 9.

Value	Meaning
0	Filter Disabled

1	Filter 111ns
2	Filter 1.78 us
3	Filter 14.22 us

Table 9 – Object 2030h – PWM Debounce Filter

Value	Meaning
0	No Filter
1	Moving Average
2	Repeating Average

Table 10 – Object 61A0h - AI Filter Type Options

Object 61A1h **AI Filter Constant** is used with all three types of filters as per the formulas below:

Calculation with no filter:

Value = Input

The data is simply a ‘snapshot’ of the latest value measured by the ADC or timer.

Equation 1 - Moving Average Transfer Function:

$$\text{Value}_N = \text{Value}_{N-1} + \frac{(\text{Input} - \text{Value}_{N-1})}{\text{Filter Constant}}$$

This filter is called every 1ms. The value Filter Constant stored in object 61A1h is 10 by default.

Equation 2 - Repeating Average Transfer Function:

$$\text{Value} = \frac{\sum_0^N \text{Input}_N}{N}$$

At every reading of the input value, it is added to the sum. At every Nth read, the sum is divided by N, and the result is the new input value. The value and counter will be set to zero for the next read. The value of N is stored in object 61A1h and is 10 by default. This filter is called every 1ms.

The value from the filter is shifted according to read-only object 2102h **AI Decimal Digits FV** and then written to read-only object 7100h **AI Input Field Value**.

It is the **AI Input FV** which is used by the application for error detection, and as a control signal for other logic blocks. Object 7100h is mappable to a TPDO and is mapped to TPDO1 by default.

1.2. Math Function Block

There are four mathematical function blocks that allow the user to define basic algorithms. A math function block can take up to six input signals. Each input is then scaled according to object 4x20h **Math Scaling 1 PV** and object 4x22h **Math Scaling 2 PV**.

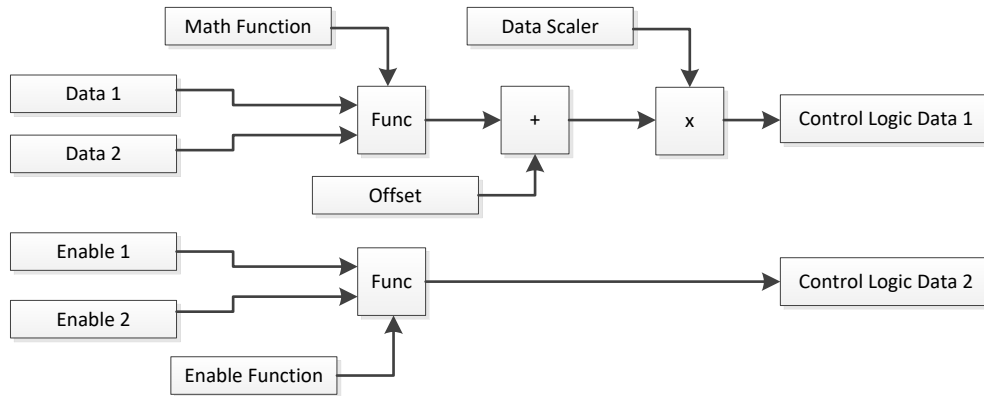

Figure 7 – Control Logic block diagram

Inputs are converted into percentage value based on the “**Input X Minimum**” and “**Input X Maximum**” values selected. For additional control the user can also adjust the “**Input X Decimal Digits**” object to increase the resolution of the input data and the min and max values.

The data and enable sources are connected to Math functions, both of which implement equation “A operator B”, where A and B are function inputs and operator is function selected with object 4x50h **Math Operator**. Allowed configuration options are presented in Table 11.

$$\text{Math Block Output} = \left(((A1 \text{ op1 } B1) \text{ op2 } B2) \text{ op3 } B3 \right) \text{ op4 } B4$$

0	=, True when InA equals InB
1	!=, True when InA not equal InB
2	>, True when InA greater than InB
3	>=, True when InA greater than or equal InB
4	<, True when InA less than InB
5	<=, True when InA less than or equal InB
6	OR, True when InA or InB is True
7	AND, True when InA and InB are True
8	XOR, True when either InA or InB is True, but not both
9	+, Result = InA plus InB
10	-, Result = InA minus InB
11	x, Result = InA times InB
12	/, Result = InA divided by InB
13	MIN, Result = Smallest of InA and InB
14	MAX, Result = Largest of InA and InB

Table 11 – Math Function Options

For logic operations (6, 7, and 8) scaled input greater than or equal to 1 is treated as TRUE. For logic operations (0 to 5), the result of the function will always be 0 (FALSE) or 1 (TRUE). For the arithmetic functions (9 to 14), it is recommended to scale the data such that the resulting operation will not exceed full scale (0 to 100%) and saturate the output result.

When dividing, a zero divider will always result in a 100% output value for the associated function.

1.3. Programmable Logic Function Block

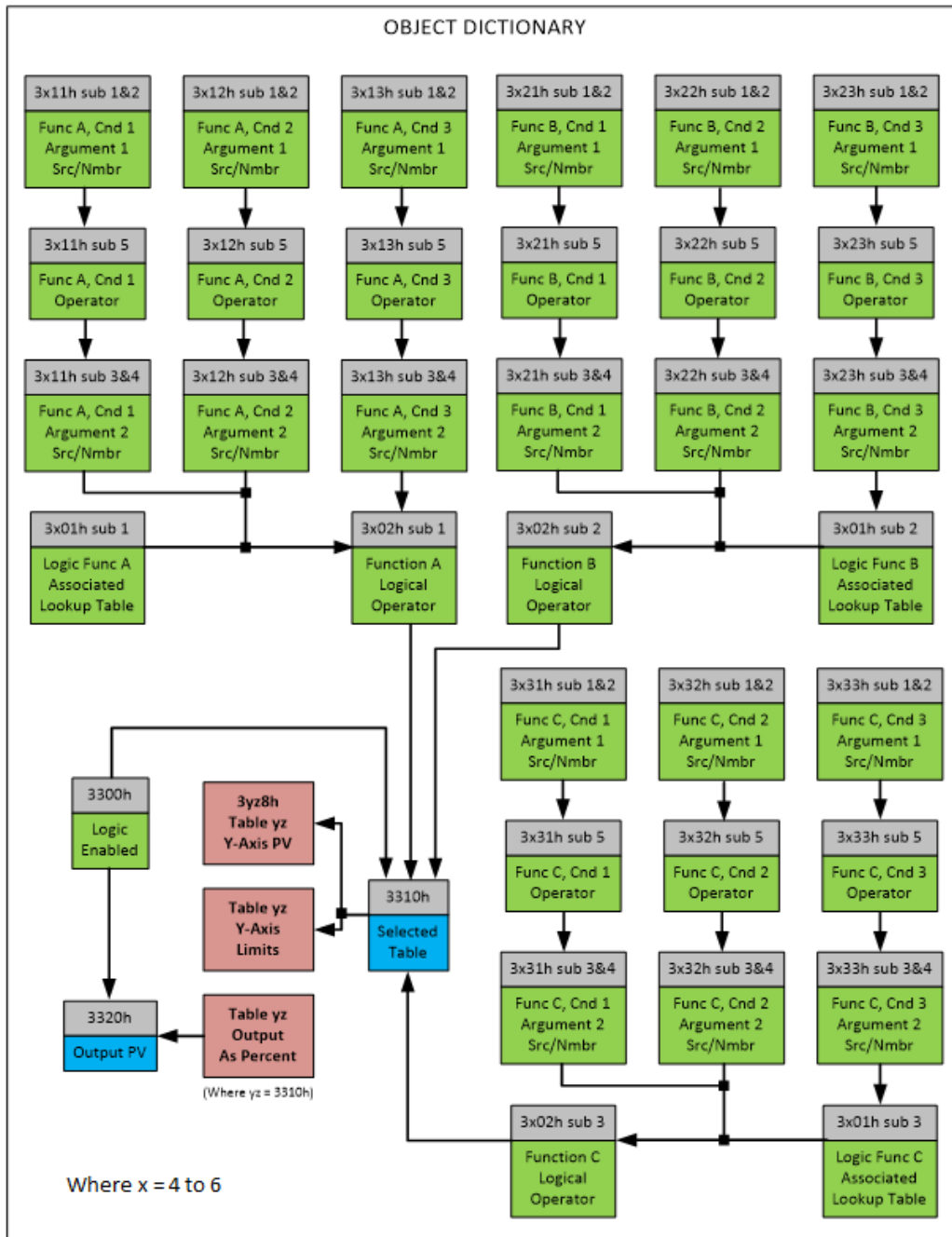

Figure 8 – Programmable Logic Block Objects

The Programmable Logic Function Block is a powerful tool. Programmable Logic can be linked to up to three (of a total of 6) Lookup Tables using object 3x01h **Logic Block[x-3] Table Numbers**, any of which would be selected only under given conditions. Should the conditions be such that a particular table (A, B or C) has been selected as described in Figure 9, then the output from the selected table, at any given time, will be passed directly to LB(x-3)'s corresponding sub-index X in

read-only mappable object 3320h **Logic Block Output PV**. The active table number can read from object 3310h **Logic Block Selected Table**.

Note: In this document, Logic Block [x-3] refers to Logic Blocks 1 to 3. Due to the CANopen® Object indices, Logic Block 1 begins at 3401h where x in this case, is 4.

The output of a Programmable Logic at any given time will be the output of the Lookup Table selected by the defined logic. Therefore, up to three different responses to the same input, or three different responses to different inputs, can become the input to another function block.

In order to enable any one of the Programmable Logic blocks, the **Logic Enabled** object 3300h must be set to *'True'*. By default, all Logic blocks are disabled.

Logic is evaluated in the order shown in Figure 9, Only if a lower indexed table (A, B, C) has not been selected will the conditions for the next table be looked at. The default table is always selected as soon as it is evaluated. It is therefore required that the default table always be the highest index in any configuration.

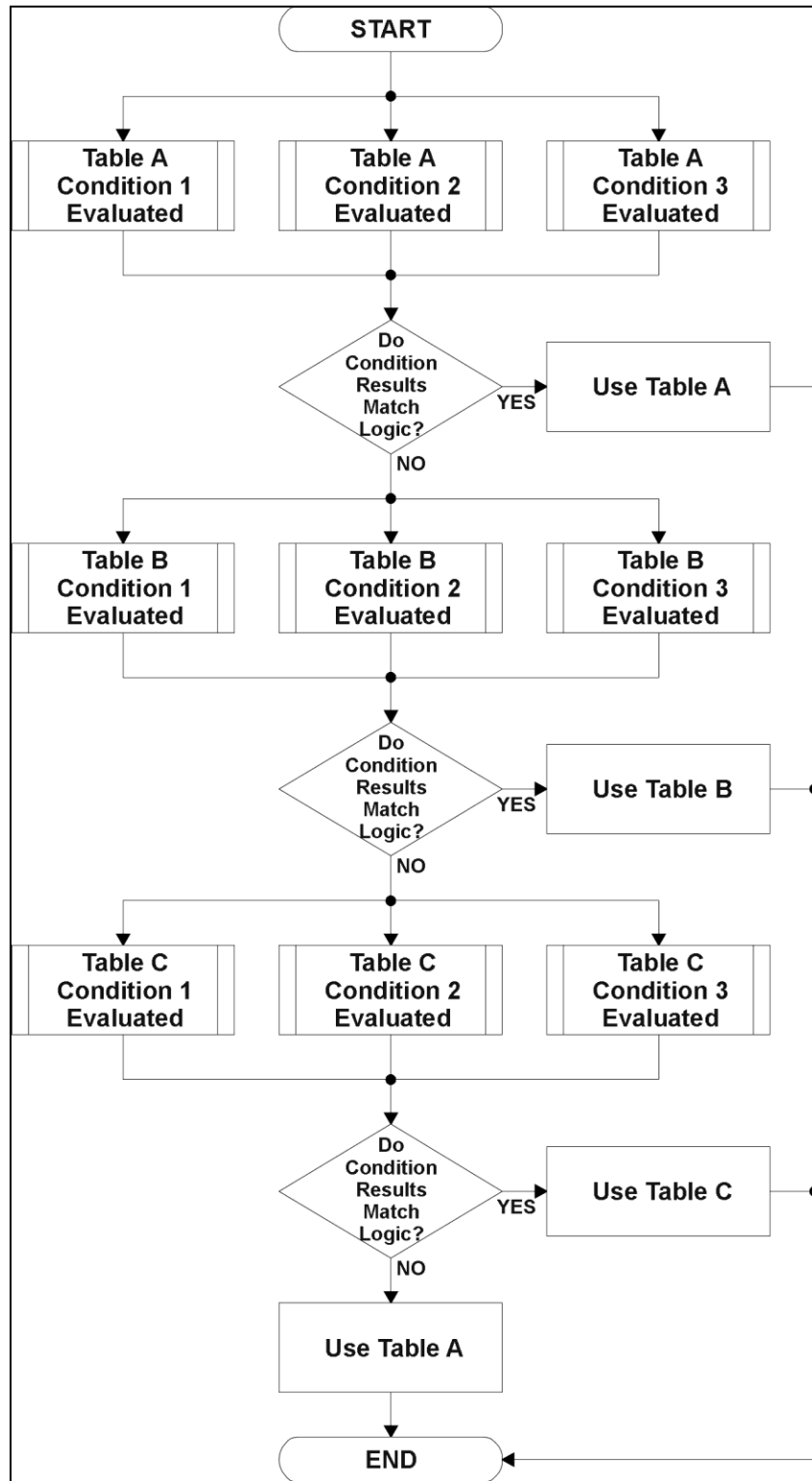

Figure 9 – Logic Block Flow Chart

For each Table Y there are three conditions that define the logic to select the associated Lookup Table as Logic output. Each condition implements the function $\{Argument1 \text{ Operator } Argument2\}$ where Argument 1, Argument 2 and Operator are defined by object 3xyzh **Logic Block [x-3] Table Y, Condition Z**.

The first step in determining which table will be selected as the active table is to first evaluate the conditions associated with a given table. Each table has associated with it up to three conditions that can be evaluated. Conditional objects are custom DEFSTRUCT objects defined as shown in Table 12.

Index	Sub-Index	Name	Data Type
3xyz*	0	Highest sub-index supported	UNSIGNED8
	1	Argument 1 Source	UNSIGNED8
	2	Argument 1 Number	UNSIGNED8
	3	Argument 2 Source	UNSIGNED8
	4	Argument 2 Number	UNSIGNED8
	5	Operator	UNSIGNED8

* Logic Block X Table Y Condition Z, where X = 4 to 6, Y = 1, 2 or 3 (A/B/C), and Z = 1 to 3

Table 12 – Logic Block [x-3] Condition Structure Definition

Objects 3x11h, 3x12h and 3x13h are the conditions evaluated for selecting Table A. Objects 3x21h, 3x22h and 3x23h are the conditions evaluated for selecting Table B. Objects 3x31h, 3x32h and 3x33h are the conditions evaluated for selecting Table C.

Argument 1 is always a logical output from another function block, as listed in Table 25. As always, the input is a combination of the functional block objects 3xyzh sub-index 1 “**Argument 1 Source**” and 3xyzh sub-index 2 “**Argument 1 Number.**”

Argument 2 on the other hand, could either be another logical output such as with Argument 1, OR a constant value set by the user. To use a constant as the second argument in the operation, set “**Argument 2 Source**” to ‘*Constant Function Block*’, and “**Argument 2 Number**” to the desired sub-index. When defining the constant, make sure it uses the same resolution (decimal digits) as the Argument 1 input.

Object 3xyzh, sub-index 5 contains the Operator used in evaluating the conditions. Options for the operator are listed in Table 13. The default value is 0 (=, Equal) for all condition objects.

0	=, <i>Equal</i>
1	!=, <i>Not Equal</i>
2	>, <i>Greater Than</i>
3	>=, <i>Greater Than or Equal</i>
4	<, <i>Less Than</i>
5	<=, <i>Less Than or Equal</i>

Table 13 – Object 3xyzh Operator Options

The three conditions are evaluated and if the result satisfies logical operation defined with Object 3x02h **Logical Operator [X-3]**, given in Table 14, the associated Lookup Table is selected as output of the Logical block. Option ‘0 – *Default Table*’ selects associated Lookup Table in all conditions.

0	<i>Default Table (Table1)</i>
1	<i>Cnd1 And Cnd2 And Cnd3</i>
2	<i>Cnd1 Or Cnd2 Or Cnd3</i>
3	<i>(Cnd1 And Cnd2) Or Cnd3</i>
4	<i>(Cnd1 Or Cnd2) And Cnd3</i>

Table 14 – Object 3[x]02h Logic Block [x-3] Logical Operator Options

The three logical operations are evaluated in order, and the first to satisfy gets selected, thus if Table1 logical operation is satisfied, the Lookup Table associated with Table1 gets selected regardless of two other logical operations. In addition, if none of the logical operations is satisfied the Lookup Table associated with Table1 gets selected by default.

1.4. Lookup Table Function Block

Lookup Tables are used to give output response up to 10 slopes per input. If more than 10 slopes are required, A Programmable Logic Block can be used to combine up to three tables to get 20 slopes as described in Section 1.3.

Note: Objects 3yznh define the Lookup Table parameters, where ‘yz’ represents the Lookup Table Number (two decimal digits, 01 to 06).

Object 3yz5h sub-index 1 defines the **Lookup Table [YZ] X-Axis Type**. By default, the tables have a ‘Data Response’ output (0). Alternatively, it can be selected as a ‘Time Response’ (1).

There are two (or three) other key parameters that will affect how this function block will behave depending on the “X-Axis Type” chosen. If chosen ‘Data Response’, then the objects 3yz0h **Lookup Table [YZ] Input X-Axis Source** and 3yz1h **Lookup Table [YZ] Input X-Axis Number** together define the control source for the function block. When it is changed, the table values in object 3yz6h **Lookup Table [YZ] Point X-Axis PV** need to be updated with new defaults based on the X-Axis source selected as described in Table 27. If however, the “X-Axis Type” is chosen to be ‘Time Response’, an additional parameter is taken into consideration - object 3yz2h, **Lookup Table [YZ] Auto Repeat**. These will be described in more detail below.

0	<i>Data Response</i>
1	<i>Time Response</i>

Table 15 – Object 3yz5 Subindex 1: X-Axis Type Options

1.4.1. X-Axis, Input Data Response

In the case where the **X-Axis Type** = ‘Data Response’, the points on the X-Axis represent the data of the control source.

However, should the minimum input be less than zero, for example a resistive input that is reflecting temperature in the range of -40°C to 210°C, then the object 3yz6h **Lookup Table [YZ] Point X-Axis PV** sub-index 1 will be set to the minimum instead, in this case -40°C.

The constraint on the X-Axis data is that the next index value is greater than or equal to the one below it, as shown in the equation below. Therefore, when adjusting the X-Axis data, it is recommended that X11 is changed first, then lower indexes in descending order.

$$\text{Min} \leq X1 \leq X2 \leq X3 \leq X4 \leq X5 \leq X6 \leq X7 \leq X8 \leq X9 \leq X10 \leq X11 \leq \text{Max}$$

Min and Max will be determined by the scaling objects associated with X-Axis Source that has been selected, as outlined in Table 27.

1.4.2. Y-Axis, Lookup Table Output

Note: By default, it is assumed that the output from the lookup table function block will be a percentage value in the range of 0 to 100.

In fact, so long as all the data in the Y-Axis is $0 \leq Y[i] \leq 100$ (where $i = 1$ to 11) then other function blocks using the lookup table as a control source will have 0 and 100 as the Scaling 1 and Scaling 2 values used in linear calculations shown in Table 27.

However, the Y-Axis has no constraints on the data that it represents. This means that inverse or increasing/decreasing or other responses can be easily established. The Y-Axis does not have to be a percentage output but could represent full scale process values instead.

In all cases, the controller looks at the entire range of the data in the Y-Axis sub-indexes and selects the lowest value as the MinOutOfRange and the highest value as the MaxOutOfRange. So long as they are not within the 0 to 100 range, they are passed directly to other function blocks as the limits on the lookup table output. (i.e., Scaling 1 and Scaling 2 values in linear calculations.)

Even if some of the data points are 'Ignored' as described in 1.4.3, they are still used in the Y-Axis range determination. If not all the data points are going to be used, it is recommended that Y10 be set to the minimum end of the range, and Y11 to the maximum first. This way, the user can get predictable results when using the table to drive another function block.

1.4.3. Point to Point Response

By default, all six lookup tables have a simple linear response from 0 to 100 in steps of 10 for both the X and Y axes. For a smooth linear response, each point in the object 3xy5h **Lookup Table [YZ] Point Response** array is set up for a 'Ramp To' output.

Alternatively, the user could select a 'Step To' response for Object 3yz5h, where $N = 2$ to 11. In this case, any input value between X_{N-1} to X_N will result in an output from the lookup table function block of Y_N . (*Recall: object 3xy5h **Lookup Table [YZ] Point Response** sub-index 1 defines the X-Axis type*)

Figure 10 shows the difference between these two response profiles with the default settings.

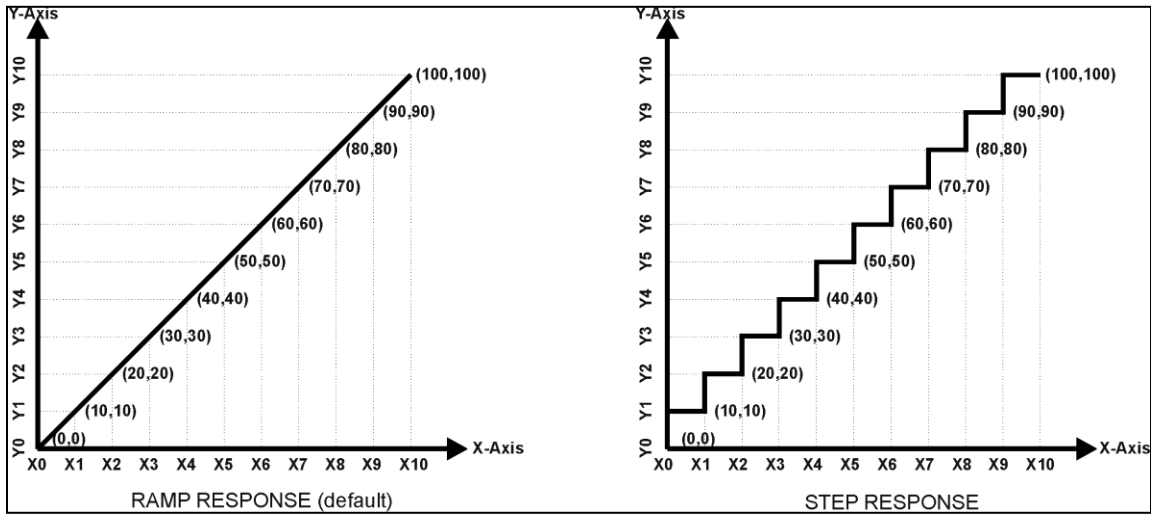

Figure 10 – Lookup Table Default Ramp and Step Responses

Lastly, any point except (1,1) can be selected for an ‘Ignore’ response. If object 3yz5h **Lookup Table [YZ] Point Response sub-index N** is set to ignore, then all points from (X_N, Y_N) to (X₁₁, Y₁₁) will also be ignored. For all data greater than X_{N-1}, the output from the lookup table function block will be Y_{N-1}.

0	<i>Ignore</i>
1	<i>Ramp To</i>
2	<i>Jump To</i>

Table 16 – Object 3yz5 Subindex 2 through 11: Response

1.4.4. Point to Point Response

A lookup table can also be used to get a custom output response where the **X-Axis Type** is a ‘Time Response’. When this is selected, the X-Axis now represents time, in units of milliseconds, while the Y-Axis still represents the output of the function block.

With this response, the sequence will start depending on two parameters:

- **Lookup Table [YZ] Input X-Axis Source** Object 3yz0h and;
- **Lookup Table [YZ] Auto Repeat** Object 3yz2h

By default, the “Auto Repeat” object is set to FALSE (0). In this case, the lookup table will react in the following way:

The X-Axis control source is treated as a digital input. When the control input is ON, the output will be changed over a period of time based on the profile in the lookup table. Once the profile has finished (i.e. reached index 11, or an ‘Ignored’ response), the output will remain at the last output at the end of the profile until the control input turns OFF.

However, when the “Auto Repeat” object is set to TRUE (1), the lookup table will react in the following way:

When the control input is ON, the output will be changed over a period based on the profile in the lookup table. Once the profile has finished (i.e., reached index 11, or an 'Ignored' response), the lookup table will revert to the first point in the table and Auto Repeat the sequence. This will continue for as long as the input remains ON. Once the input turns OFF, the lookup table sequence will stop, and the output of the lookup table is zero.

Note: When the control input is OFF, the output is always at zero. When the input comes ON, the profile will **ALWAYS** start at position (X₁, Y₁) which is 0 output for 0ms.

In a time response, the data in object 3yz6h **Lookup Table [YZ] Point X-Axis PV** is measured in milliseconds, and object 3yz3h **Lookup Table [YZ] X-Axis Decimal Digits PV** is automatically set to 0. A minimum value of 1ms must be selected for all points other than sub-index 1 which is automatically set to [0,0]. The interval time between each point on the X-axis can be set anywhere from 1ms to 24 hours. [86,400,000 ms].

1.5. Miscellaneous Function Block

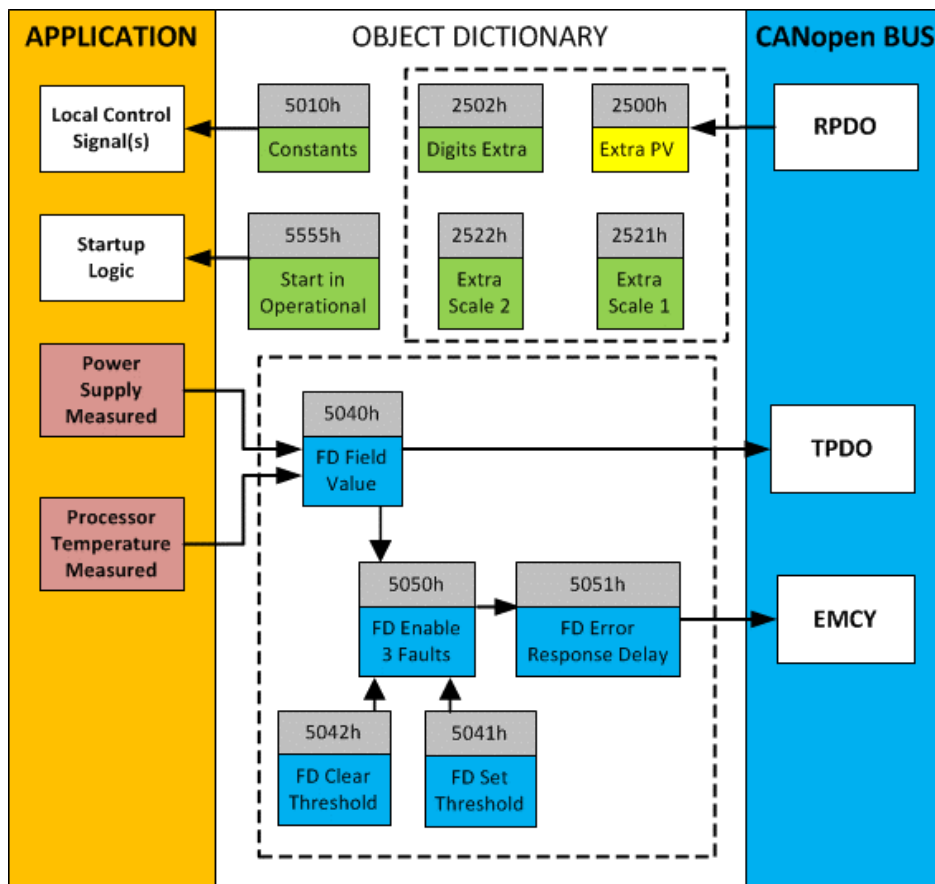

Figure 11 – Miscellaneous Objects

Extra RPDO Messages

Objects 2500h **Extra Control Received PV**, 2502h **EC Decimal Digits PV**, 2502h **EC Scaling 1 PV** and **EC Scaling 2 PV** allow for additional data received on a CANopen® RPDO to be mapped independently to various function blocks as a control source. Scaling objects are provided to define the limits of the data when it is used by another function block.

Constant Values

Object 5010h **Constant Field Value** is provided to give the user the option for a fixed value that can be used by other function blocks. Sub-index 1 is fixed as FALSE (0) and sub-index 2 is always TRUE (1). Sub-indexes 3 – 15 provide user selectable values. The default values are described in Table 17 below.

Object 5010 Subindex	Value (float32)
1	0.000000...
2	1.000000...
3	3.141593...
4	2.718282...
5	1.414214...
6	1.732051...
7	2.236068...
8	2.500000...
9	5.000000...
10	10.000000...
11	20.000000...
12	40.000000...
13	60.000000...
14	80.000000...
15	100.000000...

Table 17 – Object 5010h Constant Value Defaults

The constants are read as 32-bit real (float) data, so no decimal digit object is provided. When setting up the constant, make sure to do it with the resolution of the object that will be compared with it.

The False/True constants are provided primarily to be used with the logic block. The variable constants are also useful with logic or math blocks.

While available as a control source to all functions, it is **not** recommended to use constant data as a control source for the Set-Reset Latch block. The Set-Reset Latch block makes use of the min/max range of the control source used, which is not set when using constant data.

Startup

Object 5555h **Start in Operational** is provided as a ‘cheat’ when the unit is not intended to work with a CANopen® network (i.e. a stand-alone control) or is working on a network comprised solely as slaves so the OPERATION command will never be received from a master.

1.6. LED Control Function Block

The AX141121 unit has one configurable three-state LED to represent the information required for the application. The LED has 4 separate stages that can be configured independently, as well as a default state. The control of the LED is carried out through a unique list of control sources shown in Table 25.

Object 2A00h Stage Control Source should be set depending on the severing/importance of what is needed to be displayed by the LED for the different stages. By default, all stage control sources are set to 0 - Control Not Used. In this case, all other objects correlated with the corresponding stage are not used. Together object 2A00h and **Object 2A01h Stage Control Number** determine the control source.

Each stage provides a separate configuration for one LED with a different priority level: from the most urgent (Stage 1) to the least urgent (Stage 4). If all stages are inactive, the default stage will be active. In this case, the LED can be configured to represent a status of needed parameters in a suitable manner. The LED control object indices correspond to the priority level: subindex 1 – 4 control Stage 1 – 4 respectively. **Subindex 5 controls the default behaviour.**

Object 2A02 LED Response determines the LED response pattern. There are three possible responses, as shown in Table 18.

Value	Meaning
0	Normal On/Off
1	Blink Logic
2	Dim On/Off

Table 18 – Object 2A02 LED Response

Object 2A03 LED Type determines the color of the LED. Possible values are shown in Table 19. Default values are bolded.

Value	Meaning
0	LED Disabled
1	Green
2	Yellow
3	Red

Table 19 – Object 2A01 LED Types

Object 2A04 LED Blink Rate determines the blink rate in milliseconds [ms], if the LED Response is configured to Blink Logic.

Initially, all stages are turned off, so the LED is in the Default Stage (sub-index 5 of the LED objects mentioned).

1.7. Real Time Clock Function Block

The Real Time Clock of the controller can be configured via the CANopen® object dictionary. The RTC can be used as a control source for all available logic blocks. The subsection below explains the functionality and available parameters in more detail.

1.7.1. RTC Actual Time and Date

The Time and Date are held in **Object 2B10 RTC Output PV** in a readable format, as described in Section 3.4.24. All subindexes of this object are PDO mappable, so the date/time may be transmitted to the user's liking.

1.7.2. RTC CANopen® TIME_OF_DAY

In addition to Object 2B10, the ECU contains **Object 2B11 RTC Output FV**, which holds the date/time as a TIME_OF_DAY object, as specified in CiA standard 301. This object is structured as shown in Table 20. Note that the millisecond value is shifted by 4 bits, as there are 4 reserved bits in the TIME_OF_DAY structure per CiA Standard 301.

Subindex	Type	Meaning
0	UNSIGNED8	Number of subindexes
1	UNSIGNED32	Milliseconds since midnight, left-shifted by 4 bits
2	UNSIGNED16	Days since January 1 st , 1984.

Table 20 – Object 2B11 Output FV

1.7.3. RTC Time Zone

The time zone can be configured using **Object 2B01 RTC Time Zone**. When changing the time zone, the RTC output objects will be automatically adjusted to the local time. The subindex values and corresponding time zones are shown in Table 21. Note that when adjusting the RTC time, the time zone will be reset to UTC+0 by default.

Value	Meaning
0	UTC-12
1	UTC-11
2	UTC-10
3	UTC-9:30
4	UTC-9
5	UTC-8
6	UTC-7
7	UTC-6
8	UTC-5
9	UTC-4
10	UTC-3
11	UTC-2:30
12	UTC-2
13	UTC-1
14	UTC+0
15	UTC+1
16	UTC+2
17	UTC+3
18	UTC+4
19	UTC+4:30
20	UTC+5
21	UTC+5:30
22	UTC+5:45
23	UTC+6

24	UTC+6:30
25	UTC+7
26	UTC+8
27	UTC+8:45
28	UTC+9
29	UTC+9:30
30	UTC+10
31	UTC+10:30
32	UTC+11
33	UTC+12
34	UTC+12:45
35	UTC+13
36	UTC+14

Table 21 – Object 2B01 RTC Time Zones

1.7.4. RTC Time Adjust

Object 2B02 RTC Time Adjust is a writeable object in the same readable time/date format as object 2B10. To set the RTC, enter the current UTC+0 time and date. To set the time, set **Object 2B03 RTC Time Adjust Enable** to 1. Note that this process will also update the time zone to UTC+0. Once the time has been set, the time zone can be updated through object 2B01 to display local time.

1.8. Conditional Logic Function Block

The Conditional Block compares up to four different input sources with different logical or relational operators. The result of each block can therefore only be **true** (1) or **false** (0). Figure 12 demonstrates the connections between all parameters.

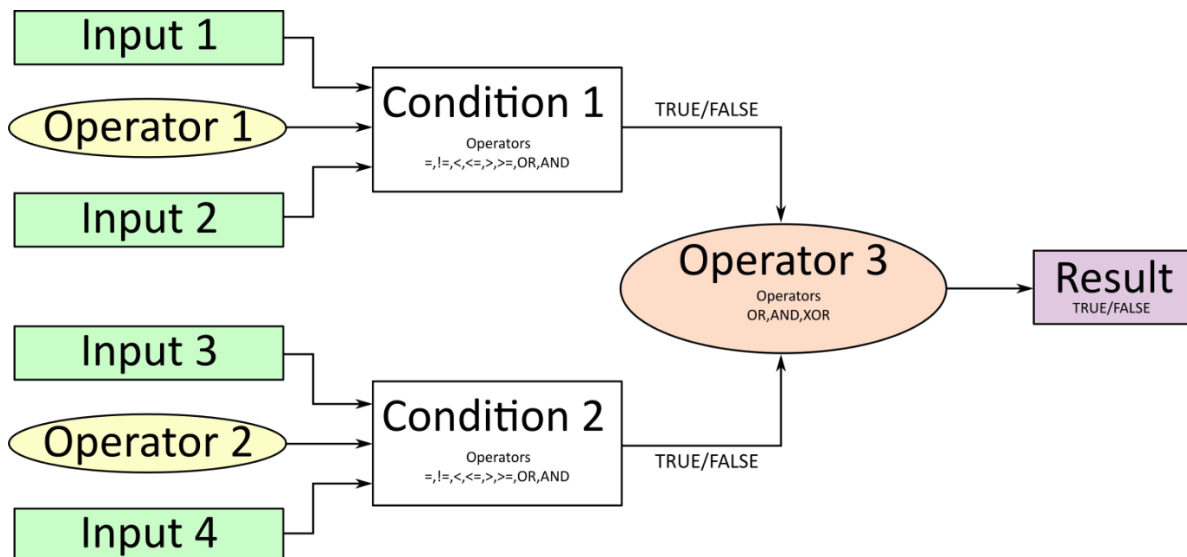

Figure 12 – Conditional Block Diagram

Each **Conditional Block [x]** offers two conditions, which are determined according to the parameters set in **Object 4Bx1h** (Condition 1) and **Object 4Bx2h** (Condition 2). Both use the defined operator to compare two inputs (argument 1 and argument 2), which can hold a logical value or an integer value. The output of the conditions can only be true or false and will be compared by Operator 3 with a logical operator. This comparison is the result of the Conditional Block and can control any output source. The output of the conditional blocks is held in the read-only object 4B10h **Conditional Logic Block Output PV**.

The value of each source will then be compared to each other with an operator of Table 22. If no source is selected, the output value of an Input will be zero. Operator 1 and Operator 2 are configured to OR by default.

Value	Meaning
0	== (True when argument 1 is equal to argument 2)
1	!= (True when argument 1 is not equal to argument 2)
2	> (True when argument 1 is greater than argument 2)
3	>= (True when Argument 1 is greater than or equal to Argument 2)
4	< (True when Argument 1 is less than Argument 2)
5	<= (True when Argument 1 is less than or equal to Argument 2)
6	OR (True when Argument 1 or Argument 2 is True)
7	AND (True when Argument 1 and Argument 2 are True)

Table 22 – Input Operator Options

The Condition Operator used for the Conditional Logic Block is assigned using object 4B01h. The table above cannot be used for comparing the conditions because they can only be compared with logical operators, which are listed in Table 23.

Value	Meaning
0	OR (True when Argument 1 or Argument 2 is True)
1	AND (True when Argument 1 and Argument 2 are True)
2	XOR (True when Argument 1 is not equal to Argument 2)

Table 23 – Condition Operator Options

If only one condition is used, it is important to make sure that Operator 3 (Condition Operator) is set to **OR** so that the result is based solely on the condition which has been chosen.

1.9. Set-Reset Latch Function Block

The Set-Reset Blocks consist of only 2 control sources: Reset and Set. The purpose of these blocks is to simulate a modified latching function in which the **Reset** signal has more precedence. The latching function works as per the Table 24 below.

Set Signal	Reset Signal	SR Latch Block Output (Initial State: OFF)

OFF	OFF	Latched State
OFF	ON	OFF
ON	OFF	ON
ON	ON	OFF

Table 24 – Set-Reset Function Block Operation

The Reset and Set sources have minimum and maximum threshold values associated with them, which determine the ON/OFF state. Reset threshold values are assigned using object 39x3h **SR Latch [x] Reset Minimum Threshold** and object 39x4h **SR Latch [x] Reset Maximum Threshold**. Set threshold values are assigned using object 39x7h **SR Latch [x] Set Minimum Threshold** and 39x8h **SR Latch [x] Set Maximum Threshold**. These values are a configurable percentage ranging from 0% to 100%, corresponding to the selected input range. The threshold values can allow for a dead band in between the ON/OFF states.

The **Reset** signal has more precedence over the **Set** signal. If the state of the Reset signal is **ON**, the state of the SR Block Output will be **OFF** regardless of the Set signal. To create an ON-output state, the Reset signal must be OFF while the Set signal is ON. Once set, the output will stay ON even if the Set signal is turned OFF, if the Reset signal is also OFF. As soon as the Reset signal turns ON the output will turn OFF, regardless of the state of the Set signal.

1.10. Available Control Sources

The 4 Universal Signal Inputs controller allows for internal function block sources to be selected from the list of the logical function blocks supported by the controller. As a result, any output from one function block can be selected as the control source for another. Keep in mind that not all options make sense in all cases, but the complete list of control sources is shown in Table 25.

Sources	Number Range	Notes
<i>0: Control Not Used</i>	N/A	
<i>1: Universal Input Measured</i>	1	
<i>2: Received CANopen® Message (RPDO)</i>	1 to 10	User must enable the desired RPDO Communication Parameter Object.
<i>3: Control Constant Data</i>	1 to 15	1 = FALSE, 2 = TRUE, 3 to 15 = User Selectable
<i>4: Math Block</i>	1 to 4	User must enable the function block, as it is disabled by default.
<i>5: Programmable Logic Block</i>	1 to 2	User must enable the function block, as it is disabled by default.
<i>6: Lookup Table</i>	1 to 6	
<i>7: Conditional Logic Block</i>	1 to 10	User must enable the function block, as it is disabled by default.
<i>8: Set-Reset Latch</i>	1 to 3	User must enable the function block, as it is disabled by default.
<i>9: RTC Seconds</i>	1 to 60	

10: RTC Minutes	1 to 60	
11: RTC Hours	1 to 24	
12: RTC Day	1 to 32	
13: RTC Year	1 to 100	

Table 25 – Available Control Sources and Numbers

Control Constant Data has no unit nor minimum and maximum assigned to it, therefore the user has to assign appropriate constant values according to intended use. While these sources are available for all functional blocks, it is not recommended to use Constant Data as a source in the Set-Reset Latch block.

Additionally, it is recommended to set the Response type as “Jump To” for the Lookup Table if it is used as a control source for the LED. When the Lookup table is an output of the Programmable Logic, and the Programmable Logic controls the LED, the Response Type should also be set to “Jump To”.

When a block uses the RTC as a control source, it will respond according to the value in the corresponding **control number** object. For example, if the LED is being controlled by the source **RTC Minutes**, and the control number is 10, the LED will respond on the 10th minute of every hour. (ex. 01:10:00, 02:10:00, etc.).

In addition to a source, each control also has a number which corresponds to the sub-index of the function block in question. Table 27 outlines the ranges supported for the number objects, depending on the source that had been selected.

Control Source	Range	Object (Meaning)
Control Source Not Used	0	Ignored
Universal Input Function Block	1	7100h sub-index 1 or 6000h sub-index 1 bit 0
	2	7100h sub-index 2 or 6000h sub-index 1 bit 1
CANopen® Message (RPDO)	1	2500h sub-index 1 (Extra Received PV 1)
	2	2500h sub-index 2 (Extra Received PV 2)
	3	2500h sub-index 3 (Extra Received PV 3)
	4	2500h sub-index 4 (Extra Received PV 4)
	5	2500h sub-index 5 (Extra Received PV 5)
	6	2500h sub-index 6 (Extra Received PV 6)
	7	2500h sub-index 7 (Extra Received PV 7)
	8	2500h sub-index 8 (Extra Received PV 8)
	9	2500h sub-index 9 (Extra Received PV 9)
	10	2500h sub-index 10 (Extra Received PV 10)
Constant Function Block	1	5010h sub-index 1 (always FALSE)
	2	5010h sub-index 2 (always TRUE)
	3	5010h sub-index 3 (Constant FV 3)
	4	5010h sub-index 4 (Constant FV 4)
	5	5010h sub-index 5 (Constant FV 5)
	6	5010h sub-index 6 (Constant FV 6)
	7	5010h sub-index 7 (Constant FV 7)
	8	5010h sub-index 8 (Constant FV 8)
	9	5010h sub-index 9 (Constant FV 9)
	10	5010h sub-index 10 (Constant FV 10)
	11	5010h sub-index 11 (Constant FV 11)

	12	5010h sub-index 12 (Constant FV 12)
	13	5010h sub-index 13 (Constant FV 13)
	14	5010h sub-index 14 (Constant FV 14)
	15	5010h sub-index 15 (Constant FV 15)
Mathematical Function Block	1	4030h sub-index 1 (Math Output PV 1)
	2	4030h sub-index 2 (Math Output PV 2)
	3	4030h sub-index 3 (Math Output PV 3)
	4	4030h sub-index 4 (Math Output PV 4)
Programmable Logic Function Block	1	3xy7h (Lookup Table Selected by Logic 1)
	2	3xy7h (Lookup Table Selected by Logic 2)
Lookup Table Function Block	1	3017h (Lookup Table 1 Output Y-Axis PV)
	2	3027h (Lookup Table 2 Output Y-Axis PV)
	3	3037h (Lookup Table 3 Output Y-Axis PV)
	4	3047h (Lookup Table 4 Output Y-Axis PV)
	5	3057h (Lookup Table 5 Output Y-Axis PV)
	6	3067h (Lookup Table 6 Output Y-Axis PV)
Conditional Logic Block	1	4B10h Subindex 1 (Cond Logic Output PV 1)
	2	4B10h Subindex 2 (Cond Logic Output PV 2)
	3	4B10h Subindex 3 (Cond Logic Output PV 3)
	4	4B10h Subindex 4 (Cond Logic Output PV 4)
	5	4B10h Subindex 5 (Cond Logic Output PV 5)
	6	4B10h Subindex 6 (Cond Logic Output PV 6)
	7	4B10h Subindex 7 (Cond Logic Output PV 7)
	8	4B10h Subindex 8 (Cond Logic Output PV 8)
	9	4B10h Subindex 9 (Cond Logic Output PV 9)
	10	4B10h Subindex 10 (Cond Logic Output PV 10)
Set-Reset Latch	1	3910h Subindex 1 (SR Latch Output PV 1)
	2	3910h Subindex 2 (SR Latch Output PV 2)
	3	3910h Subindex 3 (SR Latch Output PV 3)
RTC Seconds	1	2B10h Subindex 6 (RTC Output PV Seconds)
RTC Minutes	1	2B10h Subindex 5 (RTC Output PV Minutes)
RTC Hours	1	2B10h Subindex 4 (RTC Output PV Hours)
RTC Day	1	2B10h Subindex 3 (RTC Output PV Day)
RTC Year	1	2B10h Subindex 1 (RTC Output PV Year)

Table 26 – Control Source Objects Depending on Source Selected

When using any control source as the X-Axis input to a function block, the corresponding scaling limits are defined as per Table 27. It is the responsibility of the user to make sure that the scaling objects for any function block are set up appropriately depending on the source selected for the X-Axis input.

Control Source	Scaling 1	Scaling 2	Dec Digits
Analog Input Function Block	7120h	7122h	6132h
CANopen® Message – Num 1 to 10	2520h	2522h	2502h
Constant Function Block	N/A	N/A	N/A (float)
Mathematical Function	4021h	4023h	4032h
Programmable Logic Function	0%	100%	1 (fixed)
Lookup Table yz Function Block (where yz = 01 to 06)	0 or lowest from 3yz6h ^(*)	100 or highest from 3yz6h ^(**)	3yz3h
Set-Reset Latch	N/A	N/A	N/A

(*) - Whichever value is smaller; (**) - Whichever value is larger.

Table 27 – Scaling Limits per Control Source

2. DIMENSIONAL DRAWING

2.1. Dimensions and Pinout

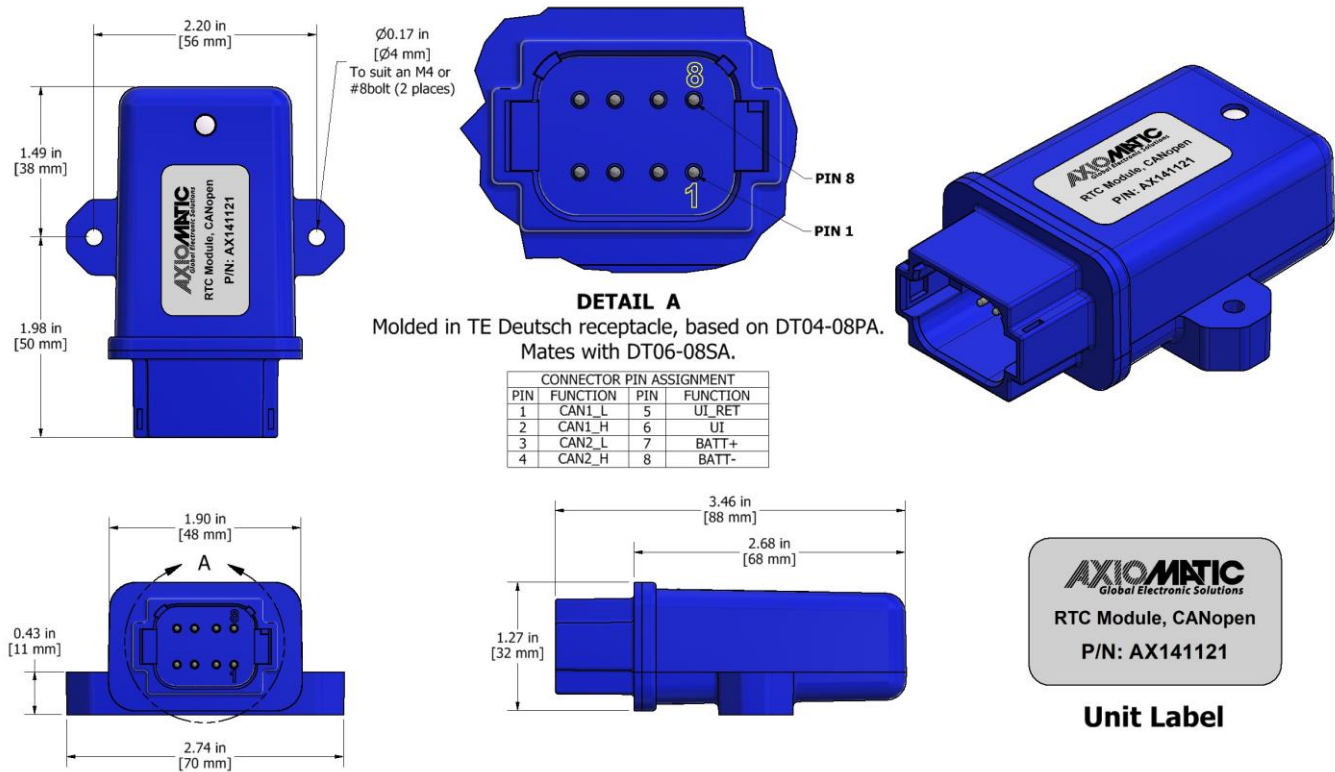

Figure 13 – AX141121 Dimensional Drawing

PIN #	Function
1	CAN 1_L
2	CAN 1_H
3	CAN 2_L
4	CAN 2_H
5	Universal Input #1 Ground
6	Universal Input #1
7	BATT+
8	BATT-

Table 28 – AX141121 Connector Pinout

3. INSTALLATION INSTRUCTIONS

The CANopen® object dictionary of the AX141121 Controller is based on CiA device profile DS-404 V1.2 (Device Profile Measuring Devices and Closed-Loop Controllers). The object dictionary includes Communication Objects beyond the minimum requirements in the profile, as well as several manufacturer-specific objects for extended functionality. The AX141121 controller supports 2 CAN interfaces which share manufacturer-specific objects and have separate communication objects.

3.1. Node ID and Baudrate

By default, the AX141121 controller ships factory programmed with:

Node ID = 127 (0x7F)

and with

Baud rate = 125 kbps.

3.1.1. LSS Protocol to Update

The only means by which the Node-ID and Baudrate can be changed is to use Layer Settling Services (LSS) and protocols as defined by CANopen® standard DS-305.

Follow the steps below to configure either variable using LSS protocol. If required, please refer to the standard for more detailed information about how to use the protocol.

3.1.1.1. Setting Node-ID

- Set the module state to LSS-configuration by **sending** the following message:

<i>Item</i>	<i>Value</i>
COB-ID	0x7E5
Length	2
Data 0	0x04 (cs=4 for switch state global)
Data 1	0x01 (switches to configuration state)

- Set the Node-ID by **sending** the following message:

<i>Item</i>	<i>Value</i>
COB-ID	0x7E5
Length	2
Data 0	0x11 (cs=17 for configure node-id)
Data 1	Node-ID (set new Node-ID as a hexadecimal number)

- The module will send the following response (any other response is a failure).

<i>Item</i>	<i>Value</i>
COB-ID	0x7E4
Length	3
Data 0	0x11 (cs=17 for configure node-id)
Data 1	0x00
Data 2	0x00

- Save the configuration by **sending** the following message:

<i>Item</i>	<i>Value</i>
COB-ID	0x7E5
Length	1
Data 0	0x17 (cs=23 for store configuration)

- The module will send the following response (any other response is a failure)

<i>Item</i>	<i>Value</i>
COB-ID	0x7E4
Length	3
Data 0	0x17 (cs=23 for store configuration)
Data 1	0x00
Data 2	0x00

- Set the module state to LSS-operation by **sending** the following message: (Note, the module will reset itself back to the pre-operational state)

<i>Item</i>	<i>Value</i>
COB-ID	0x7E5
Length	2
Data 0	0x04 (cs=4 for switch state global)
Data 1	0x00 (switches to waiting state)

3.1.1.2. Setting Baudrate

- Set the module state to LSS-configuration by sending the following message:

<i>Item</i>	<i>Value</i>
COB-ID	0x7E5
Length	2
Data 0	0x04 (cs=4 for switch state global)
Data 1	0x01 (switches to configuration state)

- Set the baudrate by sending the following message:

<i>Item</i>	<i>Value</i>
COB-ID	0x7E5
Length	3

Data 0	0x13	(cs=19 for configure bit timing parameters)
Data 1	0x00	(switches to waiting state)
Data 2	Index	(select baudrate index per Table 32)

Index	Bit Rate
0	1 Mbit/s
1	800 kbit/s
2	500 kbit/s
3	250 kbit/s
4	125 kbit/s (default)
5	reserved (100 kbit/s)
6	50 kbit/s
7	20 kbit/s
8	10 kbit/s

Table 29 – LSS Baudrate Indices

- The module will send the following response (any other response is a failure):

Item	Value
COB-ID	0x7E4
Length	3
Data 0	0x13 (cs=19 for configure bit timing parameters)
Data 1	0x00
Data 2	0x00

- Activate bit timing parameters by sending the following message:

Item	Value
COB-ID	0x7E5
Length	3
Data 0	0x15 (cs=19 for activate bit timing parameters)
Data 1	<delay_lsb>
Data 2	<delay_msb>

The delay individually defines the duration of the two periods of time to wait until the bit timing parameters switch is done (first period) and before transmitting any CAN message with the new bit timing parameters after performing the switch (second period). The time unit of switch delay is 1 ms.

- Save the configuration by sending the following message (on the NEW baudrate):

Item	Value
COB-ID	0x7E5
Length	1
Data 0	0x17 (cs=23 for store configuration)

- The module will send the following response (any other response is a failure):

Item	Value
COB-ID	0x7E4
Length	3
Data 0	0x17 (cs=23 for store configuration)
Data 1	0x00
Data 2	0x00

- Set the module state to LSS-operation by sending the following message: (Note, the module will reset itself back to the pre-operational state)

Item	Value
COB-ID	0x7E5
Length	2
Data 0	0x04 (cs=4 for switch state global)
Data 1	0x00 (switches to waiting state)

The following screen capture (left) shows the CAN data was sent (7E5h) and received (7E4h) by the tool when the baudrate was changed to 250 kbps using the LSS protocol. The other image (right) shows what was printed on an example debug RS-232 menu while the operation took place.

Between CAN Frame 98 and 99, the baudrate on the CAN Scope tool was changed from 125 to 250 kbps.

The screenshot shows the CANscope software interface on the left and an RS-232 debug menu on the right.

Left Panel (CANscope):

- Net: 0 - CAN_USB331
- Baud rate: 250
- Table of CAN frames:

Fram...	Absolute Time	RelTime	Id	Atr	L	d1	d2	d3	d4
95	11:42:45.248	6110	07E5		2	04	01		
96	11:42:54.468	9219	07E5		3	13	00	03	
97	11:42:54.468	0	07E4		3	13	00	00	
98	11:42:58.687	4218	07E5		3	15	88	13	
99	11:43:16.579	17891	07E5		1	17			
100	11:43:16.907	328	07E4		3	17	00	00	
101	11:43:23.017	6109	07E5		2	04	00		
102	11:43:23.017	0	0750		1	00			

Right Panel (RS-232 Debug Menu):

```

===== Main Menu =====
Choose one of the following:
U: View Object Dictionary
D: Default Object Dictionary
T: Toggle RS-232 Stream On/Off
S: Show/Stop Diagnostics
L: Load New Software
M: Main Menu (this)

->Node Id = 80
->Baudrate= 125 [kbps]
CO: PRE-OPERATIONAL
Activating new baud = 250 [kbps]
CO: STOP
Restarting CAN in 5000 [ms]
CO: PRE-OPERATIONAL
Storing ID
Storing Factory Parameters

Storing Baud
Storing Factory Parameters

Storing Communication Parameters

->Node Id = 80
->Baudrate= 250 [kbps]
CO: PRE-OPERATIONAL

```

3.2. Communication Objects (DS-301)

The communication objects supported by the AX141121 Controller are listed in the following table. A more detailed description of some of the objects is given in the following subchapters. Only those objects that have device-profile specific information are described. For more information on the other objects, refer to the generic CANopen® protocol specification DS-301.

Index (hex)	Object	Object Type	Data Type	Access	PDO Mapping
1000	Device Type	VAR	UNSIGNED32	RO	No
1001	Error Register	VAR	UNSIGNED8	RO	No
1002	Manufacturer Status Register	VAR	UNSIGNED32	RO	No
1003	Pre-Defined Error Field	ARRAY	UNSIGNED32	RO	No
1010	Store Parameters	ARRAY	UNSIGNED32	RW	No
1011	Restore Default Parameters	ARRAY	UNSIGNED32	RW	No
1016	Consumer Heartbeat Time	ARRAY	UNSIGNED32	RW	No
1017	Producer Heartbeat Time	VAR	UNSIGNED16	RW	No
1018	Identity Object	RECORD		RO	No
1020	Verify Configuration	ARRAY	UNSIGNED32	RO	No
1029	Error Behavior	ARRAY	UNSIGNED8	RW	No
1400	RPDO1 Communication Parameter	RECORD		RW	No
1401	RPDO2 Communication Parameter	RECORD		RW	No
1402	RPDO3 Communication Parameter	RECORD		RW	No
1403	RPDO4 Communication Parameter	RECORD		RW	No
1600	RPDO1 Mapping Parameter	RECORD		RO	No
1601	RPDO2 Mapping Parameter	RECORD		RO	No
1602	RPDO3 Mapping Parameter	RECORD		RO	No
1603	RPDO4 Mapping Parameter	RECORD		RO	No
1800	TPDO1 Communication Parameter	RECORD		RW	No
1801	TPDO2 Communication Parameter	RECORD		RW	No
1802	TPDO3 Communication Parameter	RECORD		RW	No
1803	TPDO4 Communication Parameter	RECORD		RW	No
1A00	TPDO1 Mapping Parameter	RECORD		RW	No
1A01	TPDO2 Mapping Parameter	RECORD		RW	No
1A02	TPDO3 Mapping Parameter	RECORD		RW	No
1A03	TPDO4 Mapping Parameter	RECORD		RW	No

3.2.1. 1000h Device Type

Index	Subindex	Data Type	Access	PDO Mapping	Value Range	Default Value	Description
1000	0	UINT32	RO	No	0x194	0x194	DS-402

3.2.2. 1001h Error Register

Index	Subindex	Data Type	Access	PDO Mapping	Value Range	Default Value	Description
1001	0	UINT8	RO	No	0, 1	0	Error register

3.2.3. 1002h Manufacturer Status Object

Index	Subindex	Data Type	Access	PDO Mapping	Value Range	Default Value	Description
1002	0	UINT32	RO	No	UINT32	0	Manufacturer debug information

3.2.4. 1003h Pre-Defined Error Field

This object provides an error history by listing the errors in the order that they have occurred. An error is added to the top of the list when it occurs and is immediately removed when the error condition has been cleared. The latest error is always at sub-index 1, with sub-index 0 containing the number of errors currently in the list. When the device is in an error-free state, the value of sub-index 0 is zero.

The error list may be cleared by writing a zero to sub-index 0, which will clear all errors from the list, regardless of whether they are still present. Clearing the list does NOT mean that the module will return to the error-free behavior state if at least one error is still active.

The controller has a limitation of a maximum of 14 errors in the list. If the device registers more errors, the list will be truncated, and the oldest entries will be lost.

The error codes stored in the list are 32-bit unsigned numbers, consisting of two 16-bit fields. The lower 16-bit field is the EMCY error code, and the higher 16-bit field is a manufacturer-specific code. The manufacturer-specific code is divided into two 8-bit fields, with the higher byte indicating the error description, and the lower byte indicating the channel on which the error occurred.

When an analog input is not working as described in the previous sections, then the Error Description will reflect what channel(s) is at fault using the following table. Also, if an RPDO is not received within the expected "Event Timer" period, an RPDO timeout will be flagged. Table 30 outlines the resulting Error Field Codes and their meanings.

Error Field Code	Error Description	Meaning	ID	Meaning	EMCY Code	Meaning
00000000h	EMCY Error Reset (fault no longer active)					
2001F001h	20h	AI Positive Overload (Out of Range High)	01h	Analog Input 1	F001h	Input Overload
4001F001h	40h	Negative Overload (Out of Range Low)	01h	Analog Input 1	F001h	Input Overload
20003000h	20h	Positive Overload (Vps Overvoltage)	00h	Unspecified	3000h	Generic Voltage
40003000h	40h	Negative Overload (Vps Undervoltage)	00h	Unspecified	3000h	Generic Voltage
00008100h	00h	RPDO Timeout	00h	Unspecified	8100h	Communication - generic
10008130h	10h	Lifeguard Event	00h	Unspecified	8130h	Lifeguard/Heartbe at Error
80nn8130h	80h	Heartbeat Timeout	nn	Node-ID	8130h	Lifeguard/Heartbe at Error
00008140h	00h	Bus OFF Event	00h	Unspecified	8400h	Bus OFF Recovery

Table 30 – Pre-Defined Error Field Codes

Object 1003h Description

Index	Subindex	Data Type	Access	PDO Mapping	Value Range	Default Value	Description
1003	0	UINT8	RW	No	15	15	Number of subindexes / reset error codes
	1	UINT32	RO		UINT32	0	EMCY error code #1
	2						EMCY error code #2
	3						EMCY error code #3
	4						EMCY error code #4
	5						EMCY error code #5
	6						EMCY error code #6
	7						EMCY error code #7
	8						EMCY error code #8
	9						EMCY error code #9
	10						EMCY error code #10
	11						EMCY error code #11
	12						EMCY error code #12
	13						EMCY error code #13
	14						EMCY error code #14
15	EMCY error code #15						

3.2.5. 1010h Store Parameters

Index	Subindex	Data Type	Access	PDO Mapping	Value Range	Default Value	Description
1010	0	UINT8	RO	No	4	4	Number of subindexes
	1	UINT32	RW		save	1	Write 0x65766173 ('e', 'v', 'a', 's') for storing ALL parameters
	2						Write 0x65766173 ('e', 'v', 'a', 's') for storing Communication parameters
	3						Write 0x65766173 ('e', 'v', 'a', 's') for storing Application parameters
4	Write 0x65766173 ('e', 'v', 'a', 's') for storing Manufacturer parameters						

3.2.6. 1011h Restore Parameters

Index	Subindex	Data Type	Access	PDO Mapping	Value Range	Default Value	Description
1011	0	UINT8	RO	No	4	4	Number of subindexes
	1	UINT32	RW		load	1	Write 0x4616F6C ('d', 'a', 'o', 'l') for restoring ALL parameters
	2						Write 0x4616F6C ('d', 'a', 'o', 'l') for restoring Communication parameters
	3						Write 0x4616F6C ('d', 'a', 'o', 'l') for restoring Application parameters
	4						Write 0x4616F6C ('d', 'a', 'o', 'l') for restoring Manufacturer parameters

3.2.7. 1016h Consumer Heartbeat Time

Index	Subindex	Data Type	Access	PDO Mapping	Value Range	Default Value	Description
1016	0	UINT8	RO	No	4	4	Number of subindexes
	1	UINT32	RW		UINT32	0	Consumer heartbeat time
	2						bits 31-24: reserved
	3						bits 23-16: Node ID
	4						bits 15-0: heartbeat time in milliseconds

3.2.8. 1017h Producer Heartbeat Time

Index	Subindex	Data Type	Access	PDO Mapping	Value Range	Default Value	Description
1017	0	UINT16	RW	No	10-65000	0	Producer heartbeat time in milliseconds

3.2.9. 1018h Identity Object

Index	Subindex	Data Type	Access	PDO Mapping	Value Range	Default Value	Description
1018	0	UINT8	RO	No	4	4	Number of subindexes
	1	UINT32			UINT32	0x55	Vendor ID (Axiomatic Technologies)
	2					0xAA141121	Product Code
	3						Revision Number
	4						Serial Number

3.2.10. 1020h Verify Configuration

Index	Subindex	Data Type	Access	PDO Mapping	Value Range	Default Value	Description
1020	0	UINT8	RO	No	4	4	Number of subindexes
	1	UINT32			UINT32	Configuration date: DD-MM-YYYY	
	2				Configuration time: HH-MM		

3.2.11. 1029h Error Behavior

Index	Subindex	Data Type	Access	PDO Mapping	Value Range	Default Value	Description
1029	0	UINT8	RO	No	5	5	Number of subindexes
	1		RW		0-2	1 (no change)	Behavior on Lost Communication
	2						Behavior on Digital Input Fault
	3						Behavior on Analog Input Fault
	4						Behavior on Digital Output (not used)
	5						Behavior on Analog Output (not used)

3.2.12. 1400h RPDO 1 Communication Parameters

Index	Subindex	Data Type	Access	PDO Mapping	Value Range	Default Value	Description
1400	0	UINT8	RO	No	4	4	Number of subindexes
	1	UINT32	RW		UINT32	0x4000027F	COB-ID
	2	UINT8			UINT8	0xFF	Transmission type
	3	UINT16			UINT16	0	Inhibit time
	4	UINT8			UINT8	0	Compatibility entry
	5	UINT16			UINT16	0	Event timer

3.2.13. 1401h RPDO 2 Communication Parameters

Index	Subindex	Data Type	Access	PDO Mapping	Value Range	Default Value	Description
1401	0	UINT8	RO	No	4	4	Number of subindexes
	1	UINT32	RW		UINT32	0x4000037F	COB-ID
	2	UINT8			UINT8	0xFF	Transmission type
	3	UINT16			UINT16	0	Inhibit time
	4	UINT8			UINT8	0	Compatibility entry
	5	UINT16			UINT16	0	Event timer

3.2.14. 1402h RPDO 3 Communication Parameters

Index	Subindex	Data Type	Access	PDO Mapping	Value Range	Default Value	Description
1402	0	UINT8	RO	No	4	4	Number of subindexes
	1	UINT32	RW		UINT32	0xC000047F	COB-ID
	2	UINT8			UINT8	0xFF	Transmission type
	3	UINT16			UINT16	0	Inhibit time
	4	UINT8			UINT8	0	Compatibility entry
	5	UINT16			UINT16	0	Event timer

3.2.15. 1403h RPDO 4 Communication Parameters

Index	Subindex	Data Type	Access	PDO Mapping	Value Range	Default Value	Description
1403	0	UINT8	RO	No	4	4	Number of subindexes
	1	UINT32	RW		UINT32	0xC000057F	COB-ID
	2	UINT8			UINT8	0xFF	Transmission type
	3	UINT16			UINT16	0	Inhibit time
	4	UINT8			UINT8	0	Compatibility entry
	5	UINT16			UINT16	0	Event timer

3.2.16. 1600h RPDO 1 Mapping Parameters

Index	Subindex	Data Type	Access	PDO Mapping	Value Range	Default Value	Description
1600	0	UINT8	RW	No	0-4	4	Number of subindexes
	1	UINT32			UINT32	0x25000110	EC Extra Received PV Value 1
	2					0x25000210	EC Extra Received PV Value 2
	3					0x25000310	EC Extra Received PV Value 3
	4					0x25000410	EC Extra Received PV Value 4

3.2.17. 1601h RPDO 2 Mapping Parameters

Index	Subindex	Data Type	Access	PDO Mapping	Value Range	Default Value	Description
1601	0	UINT8	RW	No	0-4	4	Number of subindexes
	1	UINT32			UINT32	0x25000510	EC Extra Received PV Value 5
	2					0x25000610	EC Extra Received PV Value 6
	3					0x25000710	EC Extra Received PV Value 7
	4					0x25000810	EC Extra Received PV Value 8

3.2.18. 1602h RPDO 3 Mapping Parameters

Index	Subindex	Data Type	Access	PDO Mapping	Value Range	Default Value	Description
1602	0	UINT8	RW	No	0-4	4	Number of subindexes
	1	UINT32			UINT32	0x25000910	EC Extra Received PV Value 9
	2					0x25000A10	EC Extra Received PV Value 10
	3					0	Not used by default
	4					0	Not used by default

3.2.19. 1603h RPDO 4 Mapping Parameters

Index	Subindex	Data Type	Access	PDO Mapping	Value Range	Default Value	Description
1603	0	UINT8	RW	No	0-4	4	Number of subindexes
	1	UINT32			UINT32	0	Not used by default
	2					0	Not used by default
	3					0	Not used by default
	4					0	Not used by default

3.2.20. 1800h TPDO 1 Communication Parameters

Index	Subindex	Data Type	Access	PDO Mapping	Value Range	Default Value	Description
1800	0	UINT8	RO	No	5	5	Number of subindexes
	1	UINT32	RW		UINT32	0x400001FF	COB-ID
	2	UINT8			UINT8	0xFE	Transmission type
	3	UINT16			UINT16	0	Inhibit time
	4	UINT8			UINT8	0	Compatibility entry
	5	UINT16			UINT16	0xFA	Event timer [milliseconds]

3.2.21. 1801h TPDO 2 Communication Parameters

Index	Subindex	Data Type	Access	PDO Mapping	Value Range	Default Value	Description
1801	0	UINT8	RO	No	5	5	Number of subindexes
	1	UINT32	RW		UINT32	0xC00002FF	COB-ID
	2	UINT8			UINT8	0xFE	Transmission type
	3	UINT16			UINT16	0	Inhibit time
	4	UINT8			UINT8	0	Compatibility entry
	5	UINT16			UINT16	0	Event timer

3.2.22. 1802h TPDO 3 Communication Parameters

Index	Subindex	Data Type	Access	PDO Mapping	Value Range	Default Value	Description
1802	0	UINT8	RO	No	5	5	Number of subindexes
	1	UINT32	RW		UINT32	0xC00003FF	COB-ID
	2	UINT8			UINT8	0xFE	Transmission type
	3	UINT16			UINT16	0	Inhibit time
	4	UINT8			UINT8	0	Compatibility entry
	5	UINT16			UINT16	0	Event timer

3.2.23. 1803h TPDO 4 Communication Parameters

Index	Subindex	Data Type	Access	PDO Mapping	Value Range	Default Value	Description
1803	0	UINT8	RO	No	4	4	Number of subindexes
	1	UINT32	RW		UINT32	0xC00004FF	COB-ID
	2	UINT8			UINT8	0xFE	Transmission type
	3	UINT16			UINT16	0	Inhibit time
	4	UINT8			UINT8	0	Compatibility entry
	5	UINT16			UINT16	0	Event timer

3.2.24. 1A00h TPDO 1 Mapping Parameters

Index	Subindex	Data Type	Access	PDO Mapping	Value Range	Default Value	Description
1A00	0	UINT8	RW	No	0-4	4	Number of subindexes
	1	UINT32			UINT32	0x71000110	Universal Input #1 FV
	2				0	Not used by default	
	3				0	Not used by default	
	4				0	Not used by default	

3.2.25. 1A01h TPDO 2 Mapping Parameters

Index	Subindex	Data Type	Access	PDO Mapping	Value Range	Default Value	Description
1A01	0	UINT8	RW	No	0-4	4	Number of subindexes
	1	UINT32			UINT32	0	Not used by default
	2				0	Not used by default	
	3				0	Not used by default	
	4				0	Not used by default	

3.2.26. 1A02h TPDO 3 Mapping Parameters

Index	Subindex	Data Type	Access	PDO Mapping	Value Range	Default Value	Description
1A02	0	UINT8	RW	No	0-4	4	Number of subindexes
	1	UINT32			UINT32	0	Not used by default
	2				0	Not used by default	
	3				0	Not used by default	
	4				0	Not used by default	

3.2.27. 1A03h TPDO 4 Mapping Parameters

Index	Subindex	Data Type	Access	PDO Mapping	Value Range	Default Value	Description
1A03	0	UINT8	RW	No	0-4	4	Number of subindexes
	1	UINT32			UINT32	0x50200020	Power Supply Field Value
	2					0x50300020	Processor Temperature Field Value
	3					0	Not used by default
	4					0	Not used by default

3.3. Application Objects (DS-404 Inputs)

Index (hex)	Object	Object Type	Data Type	Access	PDO Mapping
6000	DI Read State 8 Input Lines	VAR	UNSIGNED8	RO	Yes
6002	DI Polarity 8 Input Lines	VAR	UNSIGNED8	RW	No
6110	AI Sensor Type	ARRAY	UNSIGNED16	RW	No
6112	AI Operating Mode	ARRAY	UNSIGNED8	RW	No
6132	AI Decimal Digits PV	ARRAY	UNSIGNED8	RW	No
61A0	AI Filter Type	ARRAY	UNSIGNED8	RW	No
61A1	AI Filter Constant	ARRAY	UNSIGNED16	RW	No
7100	AI Input Field Value	ARRAY	INTEGER16	RO	Yes
7120	AI Input Scaling 1 FV	ARRAY	INTEGER16	RW	No
7121	AI Input Scaling 1 PV	ARRAY	INTEGER16	RW	No
7122	AI Input Scaling 2 FV	ARRAY	INTEGER16	RW	No
7123	AI Input Scaling 2 PV	ARRAY	INTEGER16	RW	No
7130	AI Input Process Value	ARRAY	INTEGER16	RO	Yes

3.3.1. 6000h DI Read State 8 Input Lines

Index	Subindex	Data Type	Access	PDO Mapping	Value Range	Default Value	Description
6000	0	UINT8	RO	Yes	0x0 ... 0x3F	0	Digital Input state bitmap, one bit per input.

3.3.2. 6002h DI Polarity 8 Input Lines

Index	Subindex	Data Type	Access	PDO Mapping	Value Range	Default Value	Description
6002	0	UINT8	RW	No	0x0 ... 0x3F	0	Digital Input state polarity bitmap, one bit per input.

3.3.3. 6110h AI Sensor Type

Index	Subindex	Data Type	Access	PDO Mapping	Value Range	Default Value	Description
6110	0	UINT8	RO	No	3	3	Number of subindexes
	1	UINT16	RW		40,50, 60, 10000	40	Universal Input #1 sensor type

3.3.4. 6112h AI Operating Mode

Index	Subindex	Data Type	Access	PDO Mapping	Value Range	Default Value	Description
6112	0	UINT8	RO	No	2	2	Number of subindexes
	1		RW		0,1,10,20 sensor type dependent.	1 – Analog Normal	Input #1 operating mode

3.3.5. 6132h AI Decimal Digits PV

Index	Subindex	Data Type	Access	PDO Mapping	Value Range	Default Value	Description
6132	0	UINT8	RO	No	2	2	Number of subindexes
	1		RW		0-3	3	Input #1 PV decimal digits

3.3.6. 61A0h AI Filter Type

Index	Subindex	Data Type	Access	PDO Mapping	Value Range	Default Value	Description
61A0	0	UINT8	RO	No	2	2	Number of subindexes
	1		RW		0-2	0	Input #1 software filter type
	2						Input #2 software filter type

3.3.7. 61A1h AI Filter Constant

Index	Subindex	Data Type	Access	PDO Mapping	Value Range	Default Value	Description
61A1	0	UINT8	RO	No	2	2	Number of subindexes
	1	UINT16	RW		1-1000	10	Input #1 software filter constant

3.3.8. 7100h AI Input Field Value

Index	Subindex	Data Type	Access	PDO Mapping	Value Range	Default Value	Description
7100	0	UINT8	RO	Yes	2	2	Number of subindexes
	1	INT16	RM		INT16	0	Input #1 field value

3.3.9. 7120h AI Input Scaling 1 FV

Index	Subindex	Data Type	Access	PDO Mapping	Value Range	Default Value	Description
7120	0	UINT8	RO	No	2	2	Number of subindexes
	1	INT16	RW		INT16	Input Dependent	Input #1 field value scaler 1

3.3.10. 7121h AI Input Scaling 2 FV

Index	Subindex	Data Type	Access	PDO Mapping	Value Range	Default Value	Description
7121	0	UINT8	RO	No	2	2	Number of subindexes
	1	INT16	RW		INT16		Input #1 field value scaler 2

3.3.11. 7122h AI Input Scaling 1 PV

Index	Subindex	Data Type	Access	PDO Mapping	Value Range	Default Value	Description
7122	0	UINT8	RO	No	2	2	Number of subindexes
	1	INT16	RW		INT16	0x1194	Input #1 process value scaler 1

3.3.12. 7123h AI Input Scaling 2 PV

Index	Subindex	Data Type	Access	PDO Mapping	Value Range	Default Value	Description
7123	0	UINT8	RO	No	2	2	Number of subindexes
	1	INT16	RW		INT16	0	Input #1 process value scaler 2

3.3.13. 7130h AI Input Process Value

Index	Subindex	Data Type	Access	PDO Mapping	Value Range	Default Value	Description
7130	0	UINT8	RO	No	2	2	Number of subindexes
	1	INT16	RW	Yes	INT16	0	Input #1 process value

3.4. Manufacturer Objects

<i>Index (hex)</i>	<i>Object</i>	<i>Object Type</i>	<i>Data Type</i>	<i>Access</i>	<i>PDO Mapping</i>
2100	AI Input Range	ARRAY	UNSIGNED8	RW	No
2101	AI Pulses Per Revolution	ARRAY	UNSIGNED8	RW	No
2102	AI Decimal Digits FV	ARRAY	UNSIGNED8	RW	No
2103	AI Analog Filter	ARRAY	UNSIGNED8	RW	No
2110	AI Error Detect Enable	ARRAY	UNSIGNED8	RW	No
2111	AI Error Clear Hysteresis	ARRAY	INTEGER16	RW	No
2112	AI Error Reaction Delay	ARRAY	UNSIGNED16	RW	No
2020	DI Pull Up Down Mode 1 Input Line	ARRAY	UNSIGNED8	RW	No
2030	DI Input Debounce Filter	ARRAY	UNSIGNED8	RW	No
2040	DI Debouncing Time	ARRAY	UNSIGNED16	RW	No
2060	DI Latched Logic Enabled	ARRAY	UNSIGNED8	RW	No
2500	EC Extra Received PV	ARRAY	INTEGER16	RW	Yes
2502	EC Decimal Digits PV	ARRAY	UNSIGNED8	RW	No
2520	EC Scaling 1 PV	ARRAY	INTEGER16	RW	No
2522	EC Scaling 2 PV	ARRAY	INTEGER16	RW	No
2A00	LED Control Source	ARRAY	UNSIGNED8	RW	No
2A01	LED Control Number	ARRAY	UNSIGNED8	RW	No
2A02	LED Response	ARRAY	UNSIGNED8	RW	No
2A03	LED Type	ARRAY	UNSIGNED8	RW	No
2A04	LED Blink Rate	ARRAY	UNSIGNED16	RW	No
2B01	RTC Time Zone	ARRAY	UNSIGNED8	RW	No
2B02	RTC Time Adjust	RECORD		RW	No
2B03	RTC Enable Time Adjust	ARRAY	UNSIGNED8	RW	No
2B10	RTC Output PV	RECORD		RO	Yes
2B11	RTC Output FV	RECORD	TIME_OF_DAY	RO	Yes
3300	Programmable Logic Enable	ARRAY	UNSIGNED8	RW	No
3310	Programmable Logic Output Table	ARRAY	UNSIGNED8	RO	Yes
3320	Programmable Logic Output PV	ARRAY	UNSIGNED8	RO	Yes
3401	Programmable Logic Block 1 Tables	ARRAY	UNSIGNED8	RW	No
3501	Programmable Logic Block 2 Tables	ARRAY	UNSIGNED8	RW	No
3601	Programmable Logic Block 3 Tables	ARRAY	UNSIGNED8	RW	No
3x02	Programmable Logic Block [x-3]	ARRAY	UNSIGNED8	RW	No
3x11	Prog Logic Block [x-3] Table 1 Condition	ARRAY	UNSIGNED8	RW	No
3x12	Prog Logic Block [x-3] Table 1 Condition	ARRAY	UNSIGNED8	RW	No
3x13	Prog Logic Block [x-3] Table 1 Condition	ARRAY	UNSIGNED8	RW	No
3x21	Prog Logic Block [x-3] Table 2 Condition	ARRAY	UNSIGNED8	RW	No
3x22	Prog Logic Block [x-3] Table 2 Condition	ARRAY	UNSIGNED8	RW	No

3x23	Prog Logic Block [x-3] Table 2 Condition	ARRAY	UNSIGNED8	RW	No
3x31	Prog Logic Block [x-3] Table 3 Condition	ARRAY	UNSIGNED8	RW	No
3x32	Prog Logic Block [x-3] Table 3 Condition	ARRAY	UNSIGNED8	RW	No
3x33	Prog Logic Block [x-3] Table 3 Condition	ARRAY	UNSIGNED8	RW	No
3yz0	Lookup Table [yz] Input X-Axis Source	ARRAY	UNSIGNED8	RW	No
3yz1	Lookup Table [yz] Input X-Axis Number	ARRAY	UNSIGNED8	RW	No
3yz2	Lookup Table [yz] Auto Repeat	ARRAY	UNSIGNED8	RW	No
3yz3	Lookup Table [yz] X-Axis Dec. Digits PV	ARRAY	UNSIGNED8	RW	No
3yz4	Lookup Table [yz] Y-Axis Dec. Digits PV	ARRAY	UNSIGNED8	RW	No
3yz5	Lookup Table [yz] Point Response	ARRAY	UNSIGNED8	RW	No
3yz6	Lookup Table [yz] Point X-Axis PV	ARRAY	INTEGER32	RW	No
3yz7	Lookup Table [yz] Point Y-Axis PV	ARRAY	INTEGER16	RW	No
3yz8	Lookup Table [yz] Output Y-Axis PV	ARRAY	INTEGER16	RO	Yes
4000	Math Block Enabled	ARRAY	UNSIGNED8	RW	No
4021	Math Scaling 1 PV (Output Limit Min)	ARRAY	INTEGER16	RW	No
4023	Math Scaling 2 PV (Output Limit Max)	ARRAY	INTEGER16	RW	No
4030	Math Output PV	ARRAY	INTEGER16	RO	Yes
4032	Math Decimal Digits PV	ARRAY	UNSIGNED8	RW	No
4x00	Math x Input Source	ARRAY	UNSIGNED8	RW	No
4x01	Math x Input Number	ARRAY	UNSIGNED8	RW	No
4x03	Math x Decimal Digits FV	ARRAY	UNSIGNED8	RW	No
4x20	Math x Scaling 1 FV (Input Min)	ARRAY	INTEGER16	RW	No
4x22	Math x Scaling 2 FV (Input Max)	ARRAY	INTEGER16	RW	No
4x40	Math x Gain	VAR	INTEGER8	RW	No
4x50	Math x Operator	ARRAY	UNSIGNED8	RW	No
4B00	Conditional Logic Enable	ARRAY	UNSIGNED8	RW	No
4B01	Conditional Logic Result Operator	ARRAY	UNSIGNED8	RW	No
4B10	Conditional Logic Output PV	ARRAY	UNSIGNED8	RO	Yes
4Bxy	Conditional Logic [x] Condition [y]	ARRAY	UNSIGNED8	RW	No
3900	SR Latch Enable	ARRAY	UNSIGNED8	RW	No
3910	SR Latch Output PV	ARRAY	UNSIGNED8	RO	Yes
39x1	SR Latch [x] Reset Source	ARRAY	UNSIGNED8	RW	No
39x2	SR Latch [x] Reset Number	ARRAY	UNSIGNED8	RW	No
39x3	SR Latch [x] Reset Minimum Threshold	ARRAY	UNSIGNED16	RW	No
39x4	SR Latch [x] Reset Maximum Threshold	ARRAY	UNSIGNED16	RW	No
39x5	SR Latch [x] Set Source	ARRAY	UNSIGNED8	RW	No
39x6	SR Latch [x] Set Number	ARRAY	UNSIGNED8	RW	No
39x7	SR Latch [x] Set Minimum Threshold	ARRAY	UNSIGNED16	RW	No
39x8	SR Latch [x] Set Maximum Threshold	ARRAY	UNSIGNED16	RW	No
5010	Constant Field Value	ARRAY	FLOAT32	RW	No
5020	Power Supply FV	VAR	FLOAT32	RO	Yes
5030	CPU Temperature FV	VAR	FLOAT32	RO	Yes
5500	SPP Command	ARRAY	UNSIGNED32	RWP	No
5510	SPP Response	ARRAY	UNSIGNED32	ROP	No
5550	Enable Auto Updates	VAR	BOOLEAN	RWP	No
5555	Start in Operational Mode	VAR	BOOLEAN	RWP	No
55AA	Start Bootloader	VAR	UNSIGNED8	RWP	No
5B50	Change Baud Rate	VAR	UNSIGNED8	RWP	No
5B51	Change Node ID	VAR	UNSIGNED8	RWP	No

3.4.1. 2100h AI Input Range

Index	Subindex	Data Type	Access	PDO Mapping	Value Range	Default Value	Description
2100	0	UINT8	RO	No	2	2	Number of subindexes
	1		RW		Input type dependent	0	Input #1 range selection
	2						Input #2 range selection

3.4.2. 2101h AI Number of Pulses per Revolution

Index	Subindex	Data Type	Access	PDO Mapping	Value Range	Default Value	Description
2101	0	UINT8	RO	No	2	2	Number of subindexes
	1	UINT16	RW		0-1000	0	Input #1 PPR. When 0, no rpm conversion done
	2						Input #2 PPR. When 0, no rpm conversion done

3.4.3. 2102h AI Decimal Digits FV

Index	Subindex	Data Type	Access	PDO Mapping	Value Range	Default Value	Description
2102	0	UINT8	RO	No	2	2	Number of subindexes
	1		RW		0-4	3	Input #1 decimal digits FV
	2						Input #2 decimal digits FV

3.4.4. 2103h AI Analog Filter

Index	Subindex	Data Type	Access	PDO Mapping	Value Range	Default Value	Description
2103	0	UINT8	RO	No	2	2	Number of subindexes
	1		RW		0-3	1 – 50Hz Noise Reduction	Input #1 Analog Filter
	2						Input #2 Analog Filter

3.4.5. 2110h AI Error Detect Enable

Index	Subindex	Data Type	Access	PDO Mapping	Value Range	Default Value	Description
2110	0	UINT8	RO	No	2	2	Number of subindexes
	1		RW		0– Disable 1 – Enable	0	Input #1 Error Detect Enable
	2						Input #2 Error Detect Enable

3.4.6. 2111h AI Error Clear Hysteresis

Index	Subindex	Data Type	Access	PDO Mapping	Value Range	Default Value	Description
2111	0	UINT8	RO	No	2	2	Number of subindexes
	1	INT16	RW		Input type dependent	100 [mv]	Input #1 error clear hysteresis
	2						Input #2 error clear hysteresis

3.4.7. 2112h AI Error Reaction Delay

Index	Subindex	Data Type	Access	PDO Mapping	Value Range	Default Value	Description
2112	0	UINT8	RO	No	2	2	Number of subindexes
	1	UINT16	RW		0-60000	1000	Input #1 error reaction delay [ms]
	2				Input #2 error reaction delay [ms]		

3.4.8. 2020h DI Pull Up Down Mode 1 Input Line

Index	Subindex	Data Type	Access	PDO Mapping	Value Range	Default Value	Description
2020	0	UINT8	RO	No	2	2	Number of subindexes
	1		RW		0-no pull 1 - PU	0	Input #1 pull up / down selection
	2		2 - PD		Input #2 pull up / down selection		

3.4.9. 2030h DI Debounce Filter

Index	Subindex	Data Type	Access	PDO Mapping	Value Range	Default Value	Description
2030	0	UINT8	RO	No	2	2	Number of subindexes
	1		RW		0-3	0	Input #1 debouncing filter
	2				Input #2 debouncing filter		

3.4.10. 2040h DI Debouncing Time

Index	Subindex	Data Type	Access	PDO Mapping	Value Range	Default Value	Description
2040	0	UINT16	RO	No	2	2	Number of subindexes
	1		RW		0-65535	10	Input #1 debouncing time in milliseconds
	2				Input #2 debouncing time in milliseconds		

3.4.11. 2060h DI Latched Enable

Index	Subindex	Data Type	Access	PDO Mapping	Value Range	Default Value	Description
2060	0	UINT8	RO	No	2	2	Number of subindexes
	1		RW		0-Normal 1-Latched	0	Input #1 Latched Logic Enabled
	2				Input #2 Latched Logic Enabled		

3.4.12. 2500h EC Extra Received PV

Index	Subindex	Data Type	Access	PDO Mapping	Value Range	Default Value	Description
2500	0	INT16	RO	Yes	10	10	Number of subindexes
	1		RW		-32768 to 32767	0	EC Extra Received Process Value 1
	2		EC Extra Received Process Value 2				
	3		EC Extra Received Process Value 3				
	4		EC Extra Received Process Value 4				
	5		EC Extra Received Process Value 5				
	6		EC Extra Received Process Value 6				
	7		EC Extra Received Process Value 7				
	8		EC Extra Received Process Value 8				
	9		EC Extra Received Process Value 9				
	10		EC Extra Received Process Value 10				

3.4.13. 2502h EC Decimal Digits PV

Index	Subindex	Data Type	Access	PDO Mapping	Value Range	Default Value	Description
2502	0	UINT8	RO	No	10	10	Number of subindexes
	1		RW		0 to 4	1 (0.1 resolution)	EC Decimal Digits Process Value 1
	2		EC Decimal Digits Process Value 2				
	3		EC Decimal Digits Process Value 3				
	4		EC Decimal Digits Process Value 4				
	5		EC Decimal Digits Process Value 5				
	6		EC Decimal Digits Process Value 6				
	7		EC Decimal Digits Process Value 7				
	8		EC Decimal Digits Process Value 8				
	9		EC Decimal Digits Process Value 9				
	10		EC Decimal Digits Process Value 10				

3.4.14. 2520h EC Scaling 1 PV

Index	Subindex	Data Type	Access	PDO Mapping	Value Range	Default Value	Description
2520	0	INT16	RO	Yes	10	10	Number of subindexes
	1		RW		-32768 to 2522h Sub-index [x]. Value must always be lower than 2522h (EC Scaling 2 PV) for a given sub-index.	0	EC Scaling 1 Process Value 1
	2		EC Scaling 1 Process Value 2				
	3		EC Scaling 1 Process Value 3				
	4		EC Scaling 1 Process Value 4				
	5		EC Scaling 1 Process Value 5				
	6		EC Scaling 1 Process Value 6				
	7		EC Scaling 1 Process Value 7				
	8		EC Scaling 1 Process Value 8				
	9		EC Scaling 1 Process Value 9				
	10		EC Scaling 1 Process Value 10				

3.4.15. 2522h EC Scaling 2 PV

Index	Subindex	Data Type	Access	PDO Mapping	Value Range	Default Value	Description
2522	0	INT16	RO	Yes	10	10	Number of subindexes
	1		RW		2520h Sub-index [x] to 32767. Value must always be higher than 2520h (EC Scaling 1 PV) for a given sub-index.	100.0	EC Scaling 2 Process Value 1
	2		EC Scaling 2 Process Value 2				
	3		EC Scaling 2 Process Value 3				
	4		EC Scaling 2 Process Value 4				
	5		EC Scaling 2 Process Value 5				
	6		EC Scaling 2 Process Value 6				
	7		EC Scaling 2 Process Value 7				
	8		EC Scaling 2 Process Value 8				
	9		EC Scaling 2 Process Value 9				
	10		EC Scaling 2 Process Value 10				

3.4.16. 2A00h LED Control Source

Index	Subindex	Data Type	Access	PDO Mapping	Value Range	Default Value	Description
2A00	0	UINT8	RO	No	5	5	Number of subindexes
	1		RW		0-13: See Table 25	0	LED Stage 1 Input Source
	2		LED Stage 2 Input Source				
	3		LED Stage 3 Input Source				
	4		LED Stage 4 Input Source				
	5		LED Stage 5 Input Source				

3.4.17. 2A01h LED Control Number

Index	Subindex	Data Type	Access	PDO Mapping	Value Range	Default Value	Description
2A01	0	UINT8	RO	No	5	5	Number of subindexes
	1		RW		Source Dependent: See Table 25	1	LED Stage 1 Input Number
	2						LED Stage 2 Input Number
	3						LED Stage 3 Input Number
	4						LED Stage 4 Input Number
	5						LED Stage 5 Input Number

3.4.18. 2A02h LED Response

Index	Subindex	Data Type	Access	PDO Mapping	Value Range	Default Value	Description
2A02	0	UINT8	RO	No	5	5	Number of subindexes
	1		RW		0-2: see Table 18	1 – Blink Logic	LED Stage 1 Response
	2						LED Stage 2 Response
	3						LED Stage 3 Response
	4						LED Stage 4 Response
	5						LED Stage 5 Response

3.4.19. 2A03h LED Type

Index	Subindex	Data Type	Access	PDO Mapping	Value Range	Default Value	Description
2A03	0	UINT8	RO	No	5	5	Number of subindexes
	1		RW		0-3: see Table 19	3 – Red LED	LED Stage 1 Type
	2		LED Stage 2 Type				
	3		LED Stage 3 Type				
	4		LED Stage 4 Type				
	5		LED Stage 5 Type				

3.4.20. 2A04h LED Blink Rate

Index	Subindex	Data Type	Access	PDO Mapping	Value Range	Default Value	Description
2A04	0	UINT8	RO	No	5	5	Number of subindexes
	1	UINT16	RW		0-65535	500 [ms]	LED Stage 1 Blink Rate
	2						LED Stage 2 Blink Rate
	3						LED Stage 3 Blink Rate
	4						LED Stage 4 Blink Rate
	5						LED Stage 5 Blink Rate

3.4.21. 2B01h RTC Time Zone

Index	Subindex	Data Type	Access	PDO Mapping	Value Range	Default Value	Description
2B01	0	UINT8	RO	No	1	1	Number of subindexes
	1		RW		0-36: See Table 21	14 [UTC+0]	RTC #1 Time Zone

3.4.22. 2B02h RTC Time Adjust

Index	Subindex	Data Type	Access	PDO Mapping	Value Range	Default Value	Description
2B02	0	UINT8	RO	No	6	6	Number of subindexes
	1	UINT16	RW		> 1984	0	RTC Year Adjust
	2	UINT8			1-12		RTC Month Adjust
	3				1-31		RTC Day Adjust
	4				0-23		RTC Hour Adjust
	5				0-59		RTC Minute Adjust
	6				0-59		RTC Second Adjust

3.4.23. 2B03h RTC Time Adjust Enable

Index	Subindex	Data Type	Access	PDO Mapping	Value Range	Default Value	Description
2B03	0	UINT8	RO	No	1	1	Number of subindexes
	1		RW		0-Disable 1-Enable	0	RTC Time Adjust Enable

3.4.24. 2B10h RTC Output PV

Index	Subindex	Data Type	Access	PDO Mapping	Value Range	Default Value	Description
2B10	0	UINT8	RO	Yes	6	6	Number of subindexes
	1	UINT16			> 1984	0	RTC Output Year
	2	UINT8			1-12		RTC Output Month
	3				1-31		RTC Output Day
	4				0-23		RTC Output Hour
	5				0-59		RTC Output Minute
	6				0-59		RTC Output Second

3.4.25. 2B11h RTC Output FV (CANopen® TIME_OF_DAY)

Index	Subindex	Data Type	Access	PDO Mapping	Value Range	Default Value	Description
2B11	0	UINT8	RO	No	2	2	Number of subindexes
	1	UINT32			UINT32*	0	Milliseconds past midnight, left shifted 4 bits
	2	UINT16			UINT16		Days since Jan 1 st ,1984

*Subindex 1 contains milliseconds past midnight, shifted left by 4 bits. These 4 bits will always be zero, in accordance with CiA Standard 301.

3.4.26. 3300h Programmable Logic Enable

Index	Subindex	Data Type	Access	PDO Mapping	Value Range	Default Value	Description
3300	0	UINT8	RO	No	3	3	Number of subindexes
	1		RW		0-Disabled	0	Logic Block #1 Enable
	2				1-Enabled		Logic Block #2 Enable
	3						Logic Block #3 Enable

3.4.27. 3310h Programmable Logic Selected Table

Index	Subindex	Data Type	Access	PDO Mapping	Value Range	Default Value	Description
3310	0	UINT8	RO	Yes	3	3	Number of subindexes
	1				1 to 12	1 – Table	Logic Block #1 Selected Table (Output)
	2					1	Logic Block #2 Selected Table (Output)
	3						Logic Block #3 Selected Table (Output)

3.4.28. 3320h Programmable Logic Output Process Value

Index	Subindex	Data Type	Access	PDO Mapping	Value Range	Default Value	Description
3320	0	UINT8	RO	Yes	3	3	Number of subindexes
	1				Dependent on Selected Table	0	Logic Block #1 Output PV
	2						Logic Block #2 Output PV
	3						Logic Block #3 Output PV

3.4.29. 3401h Prog Logic 1 Lookup Table Numbers

Index	Subindex	Data Type	Access	PDO Mapping	Value Range	Default Value	Description
3401	0	UINT8	RO	No	3	3	Number of subindexes
	1		RW		1 to 12	1 (Lookup Table 1)	Logic Block #1 Table 1
	2					2 (Lookup Table 2)	Logic Block #1 Table 2
	3					3 (Lookup Table 3)	Logic Block #1 Table 3

3.4.30. 3501h Prog Logic 2 Lookup Table Numbers

Index	Subindex	Data Type	Access	PDO Mapping	Value Range	Default Value	Description
3501	0	UINT8	RO	No	3	3	Number of subindexes
	1		RW		1 to 12	4 (Lookup Table 4)	Logic Block #2 Table 1
	2					5 (Lookup Table 5)	Logic Block #2 Table 2
	3					6 (Lookup Table 6)	Logic Block #2 Table 3

3.4.31. 3601h Prog Logic 3 Lookup Table Numbers

Index	Subindex	Data Type	Access	PDO Mapping	Value Range	Default Value	Description
3601	0	UINT8	RO	No	3	3	Number of subindexes
	1		RW		1 to 12	7 (Lookup Table 7)	Logic Block #3 Table 1
	2					8 (Lookup Table 8)	Logic Block #3 Table 2
	3					9 (Lookup Table 9)	Logic Block #3 Table 3

3.4.32. 3x02h Prog Logic [x-3] Function Logical Operator

This object determines how the results of the three conditions for each function are to be compared to one another to determine the overall state of the function output. There are up to three functions that can be evaluated in each logic block. The options for this object are defined in Table 14. See Section 1.3 for more information about how this object is used.

Index	Subindex	Data Type	Access	PDO Mapping	Value Range	Default Value	Description
3x02	0	UINT8	RO	Yes	3	3	Number of subindexes
	1		RW		0-4	0	Logic Block #1 Function Logical Operator
	2						Logic Block #2 Function Logical Operator
	3						Logic Block #3 Function Logical Operator

3.4.33. 3x11h Prog Logic Block [x-3] Table 1 Condition 1

3.4.34. 3x12h Prog Logic Block [x-3] Table 1 Condition 2

3.4.35. 3x13h Prog Logic Block [x-3] Table 1 Condition 3

3.4.36. 3x21h Prog Logic Block [x-3] Table 2 Condition 1

3.4.37. 3x22h Prog Logic Block [x-3] Table 2 Condition 2

3.4.38. 3x23h Prog Logic Block [x-3] Table 2 Condition 3

- 3.4.39. 3x31h Prog Logic Block [x-3] Table 3 Condition 1
- 3.4.40. 3x32h Prog Logic Block [x-3] Table 3 Condition 2
- 3.4.41. 3x33h Prog Logic Block [x-3] Table 3 Condition 3

These objects, 3xyzh, represent Logic Block [x-3], Table y, Condition z, where x = 4 to 6 (representing Logic Blocks 1 to 3), y = 1 to 3 (representing the 3 tables each logic block contains), and z = 1 to 3 (representing the 3 conditions each table has, within the Logic Block). These objects are a special type of record, defined in Table 12. See Section 1.3 for more information on how to use these objects.

Index	Subindex	Data Type	Access	PDO Mapping	Value Range	Default Value	Description
3xyz	0	UINT8	RO	No	5	5	Number of subindexes
	1		RW		0-8	0 – Off	Logic Block #[x-3] Table y Condition z Arg 1 Source
	2		Source Dependent		1	Logic Block #[x-3] Table y Condition z Arg 1 Number	
	3		0-8		0 – Off	Logic Block #[x-3] Table y Condition z Arg 2 Source	
	4		Source Dependent		1	Logic Block #[x-3] Table y Condition z Arg 2 Number	
	5		0-8		0 – '=' operator	Logic Block #[x-3] Table y Condition z Operator	

3.4.42. 3yz0h Lookup Table [yz] Input X-Axis Source

Index	Subindex	Data Type	Access	PDO Mapping	Value Range	Default Value	Description
3yz0	0	UINT8	RW	No	0-8. See Table 25	0 – Ctrl Not Used	Lookup Table [yz] Input X-Axis Source

3.4.43. 3yz1h Lookup Table [yz] Input X-Axis Number

Index	Subindex	Data Type	Access	PDO Mapping	Value Range	Default Value	Description
3yz1	0	UINT8	RW	No	Input Source dependent. See Table 25	0 – null control source	Lookup Table [yz] Input X-Axis Number

3.4.44. 3yz2h Lookup Table [yz] Auto Repeat

Index	Subindex	Data Type	Access	PDO Mapping	Value Range	Default Value	Description
3yz2	0	UINT8	RW	No	0 – Off 1 - On	0	Auto Repeat determines whether the lookup table [yz] sequence will repeat automatically.

3.4.45. 3yz3h Lookup Table [yz] X-Axis Decimal Digits PV

Index	Subindex	Data Type	Access	PDO Mapping	Value Range	Default Value	Description
3yz3	0	UINT8	RW	No	0 – 4	0	Lookup Table [yz] X Axis Decimal Digits

3.4.46. 3yz4h Lookup Table [yz] Y-Axis Decimal Digits PV

Index	Subindex	Data Type	Access	PDO Mapping	Value Range	Default Value	Description
3yz4	0	UINT8	RW	No	0 – 4	0	Lookup Table [yz] Y Axis Decimal Digits

3.4.47. 3yz5h Lookup Table [yz] Point Response

Determines Y-Axis response to X-Axis input. The value set in sub-index 1 determines the X-Axis type (i.e. data or time), while all other sub-indexes determine the response (ramp, step, ignore) between two points on the curve.

Index	Subindex	Data Type	Access	PDO Mapping	Value Range	Default Value	Description
3yz5	0	UINT8	RO	No	11	11	Number of subindexes
	1		RW		0: Data Response 1: Time Response	0	Lookup Table [yz] X-Axis Type
	2		0: Ignore 1: Ramp to 2: Jump to		1	Lookup Table [yz] Point Response 1	
	3					Lookup Table [yz] Point Response 2	
	4					Lookup Table [yz] Point Response 3	
	5					Lookup Table [yz] Point Response 4	
	6					Lookup Table [yz] Point Response 5	
	7					Lookup Table [yz] Point Response 6	
	8					Lookup Table [yz] Point Response 7	
	9					Lookup Table [yz] Point Response 8	
	10					Lookup Table [yz] Point Response 9	
	11					Lookup Table [yz] Point Response 10	

3.4.48. 3yz6h Lookup Table [yz] Point X-Axis PV

Index	Subindex	Data Type	Access	PDO Mapping	Value Range	Default Value	Description
3yz6	0	INT32	RO	No	10	10	Number of subindexes
	1		RW		Data: See Section 1.4.1 Time: 1-86400000	Data: 10*(subindex - 1) Time: No	Lookup Table [yz] Point X-axis PV1
	2		Lookup Table [yz] Point X-axis PV2				
	3		Lookup Table [yz] Point X-axis PV3				
	4		Lookup Table [yz] Point X-axis PV4				
	5		Lookup Table [yz] Point X-axis PV5				
	6		Lookup Table [yz] Point X-axis PV6				
	7		Lookup Table [yz] Point X-axis PV7				
	8		Lookup Table [yz] Point X-axis PV8				
	9		Lookup Table [yz] Point X-axis PV9				
	10		Lookup Table [yz] Point X-axis PV10				

3.4.49. 3yz7h Lookup Table [yz] Point Y-Axis PV

Index	Subindex	Data Type	Access	PDO Mapping	Value Range	Default Value	Description
3yz7	0	INT16	RO	No	10	10	Number of subindexes
	1		RW		-32768 to 32767	10*(subindex - 1)	Lookup Table [yz] Point Y-axis PV1
	2		Lookup Table [yz] Point Y-axis PV2				
	3		Lookup Table [yz] Point Y-axis PV3				
	4		Lookup Table [yz] Point Y-axis PV4				
	5		Lookup Table [yz] Point Y-axis PV5				
	6		Lookup Table [yz] Point Y-axis PV6				
	7		Lookup Table [yz] Point Y-axis PV7				
	8		Lookup Table [yz] Point Y-axis PV8				
	9		Lookup Table [yz] Point Y-axis PV9				
	10		Lookup Table [yz] Point Y-axis PV10				

3.4.50. 3yz8h Lookup Table [yz] Output Y-Axis PV

Index	Subindex	Data Type	Access	PDO Mapping	Value Range	Default Value	Description
3yz8	0	UINT8	RO	Yes	-32768 to 32767	0	Lookup Table [yz] Output Y-Axis PV

3.4.51. 4000h Math Block Enabled

Index	Subindex	Data Type	Access	PDO Mapping	Value Range	Default Value	Description
4000	0	UINT8	RO	No	5	5	Number of subindexes
	1		RW		0-Disable 1-Enable	0	Math Block #1 Enable
	2		Math Block #2 Enable				
	3		Math Block #3 Enable				
	4		Math Block #4 Enable				
	5		Math Block #5 Enable				

3.4.52. 4021h Math Scaling 1 PV (Output Limit Min)

Index	Subindex	Data Type	Access	PDO Mapping	Value Range	Default Value	Description
4021	0	INT16	RO	No	5	5	Number of subindexes
	1		RW		-32768 to 32767	0	Math Block #1 Scaling 1 PV
	2						Math Block #2 Scaling 1 PV
	3						Math Block #3 Scaling 1 PV
	4						Math Block #4 Scaling 1 PV
	5						Math Block #5 Scaling 1 PV

3.4.53. 4023h Math Scaling 2 PV (Output Limit Max)

Index	Subindex	Data Type	Access	PDO Mapping	Value Range	Default Value	Description
4023	0	INT16	RO	No	5	5	Number of subindexes
	1		RW		-32768 to 32767	10000 (100.00 in accordance with Obj 4032 – decimal digits)	Math Block #1 Scaling 2 PV
	2						Math Block #2 Scaling 2 PV
	3						Math Block #3 Scaling 2 PV
	4						Math Block #4 Scaling 2 PV
	5						Math Block #5 Scaling 2 PV

3.4.54. 4030h Math Output PV

Index	Subindex	Data Type	Access	PDO Mapping	Value Range	Default Value	Description
4030	0	INT16	RO	Yes	5	5	Number of subindexes
	1		RO		-32768 to 32767	0	Math Block #1 Output PV
	2						Math Block #2 Output PV
	3						Math Block #3 Output PV
	4						Math Block #4 Output PV
	5						Math Block #5 Output PV

3.4.55. 4032h Math Decimal Digits PV

Index	Subindex	Data Type	Access	PDO Mapping	Value Range	Default Value	Description
4032	0	UINT8	RO	No	5	5	Number of subindexes
	1		RW		0 to 4	2	Math Block #1 Decimal Digits PV
	2						Math Block #2 Decimal Digits PV
	3						Math Block #3 Decimal Digits PV
	4						Math Block #4 Decimal Digits PV
	5						Math Block #5 Decimal Digits PV

3.4.56. 4x00h Math [x] Input Source

Index	Subindex	Data Type	Access	PDO Mapping	Value Range	Default Value	Description
4x00	0	UINT8	RO	No	4	4	Number of subindexes
	1		RW		0-8: See Table 25	0	Math [x] Input Source 1
	2						Math [x] Input Source 2
	3						Math [x] Input Source 3
	4						Math [x] Input Source 4

3.4.57. 4x01h Math [x] Input Number

Index	Subindex	Data Type	Access	PDO Mapping	Value Range	Default Value	Description
4x01	0	UINT8	RO	No	4	4	Number of subindexes
	1		RW		Input Source Dependent. See Table 25, Number Range	0	Math [x] Input 1 Number
	2						Math [x] Input 2 Number
	3						Math [x] Input 3 Number
	4						Math [x] Input 4 Number

3.4.58. 4x03h Math [x] Decimal Digits FV

Index	Subindex	Data Type	Access	PDO Mapping	Value Range	Default Value	Description
4x03	0	UINT8	RO	No	4	4	Number of subindexes
	1		RW		0 to 4	2	Math [x] Input 1 Decimal Digits FV
	2						Math [x] Input 2 Decimal Digits FV
	3						Math [x] Input 3 Decimal Digits FV
	4						Math [x] Input 4 Decimal Digits FV

3.4.59. 4x20h Math [x] Scaling 1 FV

Index	Subindex	Data Type	Access	PDO Mapping	Value Range	Default Value	Description
4x20	0	INT16	RO	No	4	4	Number of subindexes
	1		RW		-32768 to 32767	0	Math [x] Input 1 Scaling 1 FV
	2						Math [x] Input 2 Scaling 1 FV
	3						Math [x] Input 3 Scaling 1 FV
	4						Math [x] Input 4 Scaling 1 FV

3.4.60. 4x22h Math [x] Scaling 2 FV

Index	Subindex	Data Type	Access	PDO Mapping	Value Range	Default Value	Description
4x22	0	INT16	RO	No	4	4	Number of subindexes
	1		RW		-32768 to 32767	10000	Math [x] Input 1 Scaling 2 FV
	2						Math [x] Input 2 Scaling 2 FV
	3						Math [x] Input 3 Scaling 2 FV
	4						Math [x] Input 4 Scaling 2 FV

3.4.61. 4x40h Math [x] Input Gain

Index	Subindex	Data Type	Access	PDO Mapping	Value Range	Default Value	Description
4x40	0	INT8	RO	No	4	4	Number of subindexes
	1		RW		-100 to 100	100 (1.00 gain)	Math [x] Input 1 Gain
	2						Math [x] Input 2 Gain
	3						Math [x] Input 3 Gain
	4						Math [x] Input 4 Gain

3.4.62. 4x50h Math [x] Operator

Index	Subindex	Data Type	Access	PDO Mapping	Value Range	Default Value	Description	
4x50	0	UINT8	RO	No	3	3	Number of subindexes	
	1		RW		0-14 See Table 11		0 (True when InA = InB)	Math [x] Function 1 Operator
	2							Math [x] Function 2 Operator
	3							Math [x] Function 3 Operator

3.4.63. 4B00h Conditional Logic Block Enable

Index	Subindex	Data Type	Access	PDO Mapping	Value Range	Default Value	Description	
4B00	0	UINT8	RO	No	10	10	Number of subindexes	
	1		RW		0-Disabled		0	Conditional Logic Block #1 Enable
	2				1-Enabled			Conditional Logic Block #2 Enable
	3							Conditional Logic Block #3 Enable
	4							Conditional Logic Block #4 Enable
	5							Conditional Logic Block #5 Enable
	6							Conditional Logic Block #6 Enable
	7							Conditional Logic Block #7 Enable
	8							Conditional Logic Block #8 Enable
	9							Conditional Logic Block #9 Enable
	10							Conditional Logic Block #10 Enable

3.4.64. 4B01h Conditional Logic Block Result Operator

Index	Subindex	Data Type	Access	PDO Mapping	Value Range	Default Value	Description	
4B01	0	UINT8	RO	No	10	10	Number of subindexes	
	1		RW		0 - OR		0	Conditional Logic Block [x] Operator
	2				1 - AND			Conditional Logic Block [x] Operator
	3				2 - XOR			Conditional Logic Block [x] Operator
	4							Conditional Logic Block [x] Operator
	5							Conditional Logic Block [x] Operator
	6							Conditional Logic Block [x] Operator
	7							Conditional Logic Block [x] Operator
	8							Conditional Logic Block [x] Operator
	9							Conditional Logic Block [x] Operator
	10							Conditional Logic Block [x] Operator

3.4.65. 4B10h Conditional Logic Block Output Process Value

Index	Subindex	Data Type	Access	PDO Mapping	Value Range	Default Value	Description	
4B10	0	UINT8	RO	Yes	10	10	Number of subindexes	
	1		RO		0 - FALSE		0	Conditional Logic Block [x] Output PV
	2				1 - TRUE			Conditional Logic Block [x] Output PV
	3							Conditional Logic Block [x] Output PV
	4							Conditional Logic Block [x] Output PV
	5							Conditional Logic Block [x] Output PV
	6							Conditional Logic Block [x] Output PV
	7							Conditional Logic Block [x] Output PV
	8							Conditional Logic Block [x] Output PV
	9							Conditional Logic Block [x] Output PV
	10							Conditional Logic Block [x] Output PV

3.4.66. 4Bxyh Conditional Logic Block [x] Condition [y] Parameters

Index	Subindex	Data Type	Access	PDO Mapping	Value Range	Default Value	Description
4Bxy	0	UINT8	RO	No	5	5	Number of subindexes
	1		RW		0-8	0 – Off	Cond Logic Block #[x] Condition y Arg 1 Source
	2				Source Dependent	1	Cond Logic Block #[x] Condition y Arg 1 Number
	3		0-8		0 – Off	Cond Logic Block #[x] Condition y Arg 2 Source	
	4		Source Dependent		1	Cond Logic Block #[x] Condition y Arg 2 Number	
	5		0-8		0 – '=' operator	Cond Logic Block #[x] Condition y Operator	

3.4.67. 3900h Set-Reset Latch Enable

Index	Subindex	Data Type	Access	PDO Mapping	Value Range	Default Value	Description
3900	0	UINT8	RO	No	5	5	Number of subindexes
	1		RW		0-Disabled	0	SR Latch Block #1 Enable
	2				1-Enabled		SR Latch Block #2 Enable
	3				SR Latch Block #3 Enable		
	4				SR Latch Block #4 Enable		
	5				SR Latch Block #5 Enable		

3.4.68. 3910h Set-Reset Latch Output PV

Index	Subindex	Data Type	Access	PDO Mapping	Value Range	Default Value	Description
3910	0	UINT8	RO	Yes	5	5	Number of subindexes
	1		RO		0-Output OFF	0	SR Latch Block #1 Output PV
	2				1-Output ON		SR Latch Block #2 Output PV
	3				SR Latch Block #3 Output PV		
	4				SR Latch Block #4 Output PV		
	5				SR Latch Block #5 Output PV		

3.4.69. 39x1h SR Latch [X] Reset Signal Source

Index	Subindex	Data Type	Access	PDO Mapping	Value Range	Default Value	Description
39x1	0	UINT8	RW	No	0-8: See Control Sources, Table 25 Sources	0 – control not used	SR Latch Block #[x] Reset Signal Source

3.4.70. 39x2h SR Latch [X] Reset Signal Number

Index	Subindex	Data Type	Access	PDO Mapping	Value Range	Default Value	Description
39x2	0	UINT8	RW	No	Input Dependent. See Control Sources, Table 25 Number Range	1	SR Latch Block #[x] Reset Signal Number

3.4.71. 39x3h SR Latch [X] Reset Signal OFF Threshold

Index	Subindex	Data Type	Access	PDO Mapping	Value Range	Default Value	Description
39x3	0	FLOAT32	RW	No	0 – 100%	0.0	SR Latch [x] Reset signal is OFF when below this threshold. The percentage applies to the range of the input type used.

3.4.72. 39x4h SR Latch [X] Reset Signal ON Threshold

Index	Subindex	Data Type	Access	PDO Mapping	Value Range	Default Value	Description
39x4	0	FLOAT32	RW	No	0 – 100%	100.0	SR Latch [x] Reset signal is ON when above this threshold. The percentage applies to the range of the input type used.

3.4.73. 39x5h SR Latch [X] Set Signal Source

Index	Subindex	Data Type	Access	PDO Mapping	Value Range	Default Value	Description
39x5	0	UINT8	RW	No	0-8: See Control Sources, Table 25 Sources	0 – control not used	SR Latch Block #[x] Set Signal Source

3.4.74. 39x6h SR Latch [X] Set Signal Number

Index	Subindex	Data Type	Access	PDO Mapping	Value Range	Default Value	Description
39x6	0	UINT8	RW	No	Input Dependent. See Control Sources, Table 25 Number Range	1	SR Latch Block #[x] Set Signal Number

3.4.75. 39x7h SR Latch [X] Set Signal OFF Threshold

Index	Subindex	Data Type	Access	PDO Mapping	Value Range	Default Value	Description
39x7	0	FLOAT32	RW	No	0 – 100%	0.0	SR Latch [x] Set signal is OFF when below this threshold. The percentage applies to the range of the input type used.

3.4.76. 39x8h SR Latch [X] Set Signal ON Threshold

Index	Subindex	Data Type	Access	PDO Mapping	Value Range	Default Value	Description
39x8	0	FLOAT32	RW	No	0 – 100%	100.0	SR Latch [x] Set signal is ON when above this threshold. The percentage applies to the range of the input type used.

3.4.77. 5010h Constant Field Value

Index	Subindex	Data Type	Access	PDO Mapping	Value Range	Default Value	Description	
5010	0	UINT8	RO	No	12	12	Number of subindexes	
	1	FLOAT32	RW		No	FLOAT32	0.0	User modifiable constant values to be used in custom control application.
	2						1.0	
	3						3.14159	
	4						2.71828	
	5						1.41421	
	6						1.73205	
	7						2.23607	
	8						2.5	
	9						5.0	
	10						10.0	
	11						20.0	
	12						40.0	
	13						60.0	
	14						80.0	
15	100.0							

3.4.78. 5020h Power Supply FV

Index	Subindex	Data Type	Access	PDO Mapping	Value Range	Default Value	Description
5020	0	FLOAT32	RO	Yes	FLOAT32	0	Measured power supply voltage

3.4.79. 5030h CPU Temperature FV

Index	Subindex	Data Type	Access	PDO Mapping	Value Range	Default Value	Description
5030	0	FLOAT32	RO	Yes	FLOAT32	0	Measured CPU internal temperature

3.4.80. 5500h SPP Command

Index	Subindex	Data Type	Access	PDO Mapping	Value Range	Default Value	Description	
5500	0	UINT8	RO	No	3	3	Number of subindexes	
	1	UINT32	RW		UINT32	0	Node ID, data length, function ID, command id	
	2							Byte3, byte2, byte1, byte0
	3							

3.4.81. 5510h SPP Response

Index	Subindex	Data Type	Access	PDO Mapping	Value Range	Default Value	Description
5510	0	UINT8	RO	No	3	3	Number of subindexes
	1	UINT32	RO		UINT32	0	
	2						
	3						

3.4.82. 5550h Enable Auto Updates

Index	Subindex	Data Type	Access	PDO Mapping	Value Range	Default Value	Description
5550	0	UINT8	RW	No	0-1	0	Enable/Disable Auto Updates.

3.4.83. 5555h Start In Operational Mode

Index	Subindex	Data Type	Access	PDO Mapping	Value Range	Default Value	Description
5555	0	UINT8	RW	No	0-3	0	0 – No action, wait NMT commands 1 – Start directly in operational mode 2 – Start in operational mode and send NMT for starting also other devices 3 – Start in operational mode and set PDS FSA to Enabled Mode.

3.4.84. 55AAh Start Bootloader

Index	Subindex	Data Type	Access	PDO Mapping	Value Range	Default Value	Description
55AA	0	UINT8	RW	No	0-1	0	Starts the bootloader if value is 1.

3.4.85. 5B50h Change Baud Rate

Index	Subindex	Data Type	Access	PDO Mapping	Value Range	Default Value	Description
5B50	0	UINT8	RW	No	0-4, 6-8.	4	125 kbps by default. 5 is reserved for future use.

3.4.86. 5B51h Change Node ID

Index	Subindex	Data Type	Access	PDO Mapping	Value Range	Default Value	Description
5B51	0	UINT8	RW	No	0-127	127	Change the Node ID

APPENDIX A - TECHNICAL SPECIFICATION

Specifications are indicative and subject to change. Actual performance will vary depending on the application and operating conditions. Users should satisfy themselves that the product is suitable for use in the intended application. All our products carry a limited warranty against defects in material and workmanship. Please refer to our Warranty, Application Approvals/Limitations and Return Materials Process as described on <https://www.axiomatic.com/service/>.

Power

Power Supply Input - Nominal	12V, 24V or 48Vdc nominal; 8...90 Vdc The minimum allowable supply voltage for the power pin is 7 Vdc.
Surge Protection	Meets the surge requirements of SAE J1445
Reverse Polarity Protection	Provided
RTC Battery Supply	Battery backup – RTC, 3V 15 years operation minimum

Input

Universal Signal Input	1 Universal Signal Input selectable as: Voltage, Current, PWM or Digital 12-bit Analog to Digital (voltage, current) Protected against shorts to GND or +Supply Voltage Type: 0-5 Vdc, 0-10 Vdc Current Type: 0-20 mA or 4-20 mA Current sense resistor 124Ω PWM or Frequency Type: 0.1 Hz to 10,000 Hz 0-100% D.C. 0.01% Resolution Digital Type: Active High up to +Vps or Active Low to Ground 10 kΩ Pullup/Pulldown Amplitude: 0V to +Vps
Input Accuracy	Voltage: +/- 0.5% Current: +/- 0.5% PWM Signal: +/- 1% Frequency Signal: +/- 1%

Control Software

Software Platform	Pre-programmed with standard logic. Refer to the user manual. <i>Note: During the first start, the device's parameters are set to default. Also, the time and date of the RTC can be adjusted via CAN. So, it is possible to use the RTC module without configuration for default input type configurations. However, in this case, it will not be possible to change other parameters (such as an Input Type).</i>
-------------------	--

General Specifications

Microcontroller	STM32F413CGU6, 1024 Kbytes Flash Program Memory
CAN Port	2 CAN (CANopen®)
Quiescent Current Draw	13.3mA @ 12Vdc; 7.7 mA @ 24Vdc
Operating Conditions	-40 to 85°C (-40 to 185°F)
LED Indicator	Provided
Weight	0.15 lb. (0.068 kg)
Protection Rating	IP67
Vibration	MIL-STD-202G, Test 204D and 214A (Sine and Random) 10 g peak (Sine); 7.85 Grms peak (Random)
Shock	MIL-STD-202G, Test 213B, 50 g
Enclosure and Dimensions	Molded Enclosure, integral connector Nylon 6/6, 30% glass Ultrasonically welded 3.47 x 2.75 x 1.31 inches (88.2 x 70.0 x 33.3 mm) L x W x H including integral connector Refer to dimensional drawing.
User Interface	EDS File is provided. Standard CANopen® tools (not provided)
Reflashing Firmware	The Axiomatic Electronic Assistant KIT, P/Ns: AX070502 or AX070506K

CANopen® is a registered community trademark of CAN in Automation e.V.

OUR PRODUCTS

AC/DC Power Supplies
Actuator Controls/Interfaces
Automotive Ethernet Interfaces
Battery Chargers
CAN Controls, Routers, Repeaters
CAN/WiFi, CAN/Bluetooth, Routers
Current/Voltage/PWM Converters
DC/DC Power Converters
Engine Temperature Scanners
Ethernet/CAN Converters,
Gateways, Switches
Fan Drive Controllers
Gateways, CAN/Modbus, RS-232
Gyroscopes, Inclinometers
Hydraulic Valve Controllers
Inclinometers, Triaxial
I/O Controls
LVDT Signal Converters
Machine Controls
Modbus, RS-422, RS-485 Controls
Motor Controls, Inverters
Power Supplies, DC/DC, AC/DC
PWM Signal Converters/Isolators
Resolver Signal Conditioners
Service Tools
Signal Conditioners, Converters
Strain Gauge CAN Controls
Surge Suppressors

OUR COMPANY

Axiomatic provides electronic machine control components to the off-highway, commercial vehicle, electric vehicle, power generator set, material handling, renewable energy and industrial OEM markets. ***We innovate with engineered and off-the-shelf machine controls that add value for our customers.***

QUALITY DESIGN AND MANUFACTURING

We have an ISO9001:2015 registered design/manufacturing facility in Canada.

WARRANTY, APPLICATION APPROVALS/LIMITATIONS

Axiomatic Technologies Corporation reserves the right to make corrections, modifications, enhancements, improvements, and other changes to its products and services at any time and to discontinue any product or service without notice. Customers should obtain the latest relevant information before placing orders and should verify that such information is current and complete. Users should satisfy themselves that the product is suitable for use in the intended application. All our products carry a limited warranty against defects in material and workmanship. Please refer to our Warranty, Application Approvals/Limitations and Return Materials Process at <https://www.axiomatic.com/service/>.

COMPLIANCE

Product compliance details can be found in the product literature and/or on axiomatic.com. Any inquiries should be sent to sales@axiomatic.com.

SAFE USE

All products should be serviced by Axiomatic. Do not open the product and perform the service yourself.



This product can expose you to chemicals which are known in the State of California, USA to cause cancer and reproductive harm. For more information go to www.P65Warnings.ca.gov.

SERVICE

All products to be returned to Axiomatic require a Return Materials Authorization Number (RMA#) from sales@axiomatic.com. Please provide the following information when requesting an RMA number:

- Serial number, part number
- Runtime hours, description of problem
- Wiring set up diagram, application and other comments as needed

DISPOSAL

Axiomatic products are electronic waste. Please follow your local environmental waste and recycling laws, regulations and policies for safe disposal or recycling of electronic waste.

CONTACTS

Axiomatic Technologies Corporation
1445 Courtneypark Drive E.
Mississauga, ON
CANADA L5T 2E3
TEL: +1 905 602 9270
FAX: +1 905 602 9279
www.axiomatic.com
sales@axiomatic.com

Axiomatic Technologies Oy
Höytämöntie 6
33880 Lempäälä
FINLAND
TEL: +358 103 375 750
www.axiomatic.com
salesfinland@axiomatic.com