

USER MANUAL

USB to CAN Converter

P/N: AX070505

ACRONYMS

| | |
|-------|---|
| ABS | Acrylonitrile butadiene styrene (thermoplastic polymer) |
| AF | Application Firmware |
| AX | Axiomatic |
| °C | Celsius (degree) |
| CAN | Controller Area Network |
| CE | Conformité Européenne (European Conformity) |
| CIA | CAN in Automation |
| D-sub | D-subminiature |
| DIN | German Institute for Standardization |
| EA | Axiomatic Electronic Assistant (PC application software from Axiomatic) |
| EMC | Electromagnetic Compatibility |
| EN | European Norms (European Standards) |
| ESD | Electrostatic Discharge |
| FS | Full Speed |
| GND | Ground |
| H | Height (for size) |
| HS | High Speed |
| HVCI | Hypervisor-Protected Code Integrity |
| ID | Identifier |
| IEC | International Electrotechnical Commission |
| IP | Ingress Protection |
| L | Length (for size) |
| lbs | Pounds |
| LED | Light-Emitting Diode |
| kV | kilovolt |
| mA | milliamperes |
| N/A | Not Applicable or Not Assigned |
| P/N | Part Number |
| RGB | Red-Green-Blue |
| RMS | Root mean square |
| RoHS | Restriction of Hazardous Substances |
| SDK | Software Development Kit |
| uC | Microcontroller |
| UL | Underwriters Laboratories (safety organization) |
| USB | Universal Serial Bus |
| V | Volt |
| W | Width (for size) |

TABLE OF CONTENTS

| | | |
|-------|--------------------------------|----|
| 1 | INTRODUCTION | 4 |
| 2 | CONVERTER DESCRIPTION..... | 5 |
| 2.1 | Hardware Block Diagram..... | 5 |
| 2.2 | Status LED | 6 |
| 2.3 | Firmware Organization | 7 |
| 2.4 | CAN Bus Connection..... | 8 |
| 2.4.1 | Workbench Connection | 8 |
| 3 | DRIVER INSTALLATION..... | 10 |
| 3.1 | Installation Example | 10 |
| 4 | FIRMWARE UPDATE..... | 14 |
| 4.1 | Connecting to Converter..... | 14 |
| 4.2 | Loading Firmware File..... | 15 |
| 4.3 | Flashing Firmware..... | 15 |
| 4.4 | Applying the New Firmware..... | 16 |
| 5 | TECHNICAL SPECIFICATIONS..... | 17 |
| 5.1 | USB Port | 17 |
| 5.2 | CAN Port | 17 |
| 5.3 | LED Indicator..... | 17 |
| 5.4 | General Specifications..... | 18 |
| 5.5 | Software | 18 |
| 5.6 | Accessories | 18 |
| 5.7 | CAN Connector | 18 |
| 5.8 | Housing | 19 |
| 6 | VERSION HISTORY..... | 20 |

1 INTRODUCTION

The following user manual describes architecture and functionality of the USB to CAN Converter. It also contains technical specifications of the converter.

This converter is intended to replace Axiomatic USB-CAN Converter, p/n AX070501. The converter application firmware continues version numbering of AX070501 and starts from version 2.00 to facilitate the use of legacy software designed for AX070501.

The user manual is valid for application firmware with the same major version number as the user manual. For example, this user manual is valid for any application firmware version 2.xx. Updates specific to the user manual are done by adding letters: A, B, ..., Z to the user manual version number.

2 CONVERTER DESCRIPTION

The converter is intended to provide a communication link between a computer USB port and a CAN network to allow PC software to communicate with Axiomatic controls on the CAN network. It is designed to be a drop-in replacement of the Axiomatic USB-CAN Converter, p/n AX070501, with a smaller housing and a faster USB port.

The converter contains a high-speed USB port (up to 480Mbit/s) and one DB9 high-speed CAN port with configurable baud rates up to 1Mbit/s. All standard and extended CAN frames, including data and remote frames, are supported. Galvanic isolation of the CAN port ensures no electrical interference between the PC and equipment connected to the CAN port.

The converter is powered from the USB port. The internal state of the converter is displayed by a LED indicator on the housing. The industrial temperature range (-40...+85 °C) is suitable for a field environment.

The converter uses a proprietary communication protocol and requires Axiomatic drivers to be installed on the user's PC. All software from the Axiomatic Electronic Assistant suite: Axiomatic Electronic Assistant (EA), Axiomatic Electronic Assistant – Scope, and Axiomatic Electronic Assistant – Visual supports this converter. Axiomatic provides USB to CAN Converter SDK, p/n AX070501SDK, to support third-party software development.

The converter firmware can be updated in the field through the USB port using Axiomatic USB-CAN Converter Firmware Update Tool.

2.1 Hardware Block Diagram

The converter hardware block diagram is presented in Figure 1.

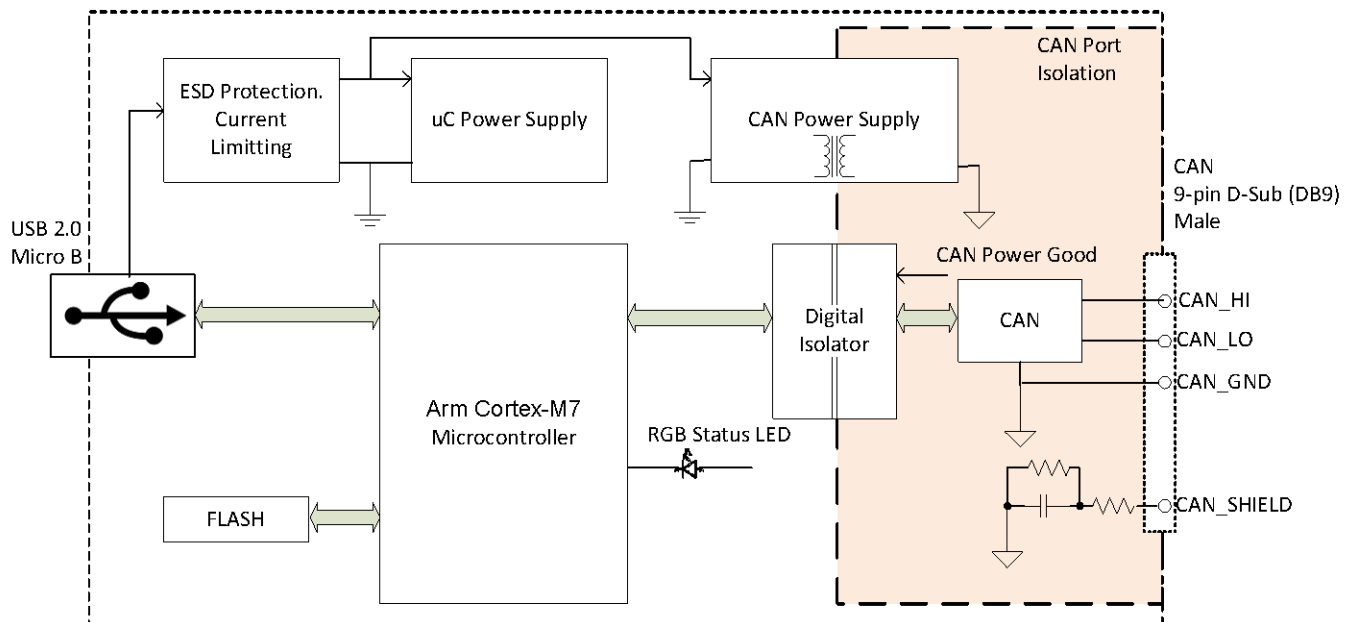

Figure 1. The Converter Hardware Block Diagram

The converter is powered from the USB port. ESD protection and current limiting is provided.

The CAN port is galvanically isolated from the USB port and the rest of the converter.

A powerful 32-bit ARM Cortex-M7 microcontroller ensures minimum delay in processing CAN and USB messages.

A three-color RGB Status LED indicates the internal state of the converter.

2.2 Status LED

The Status LED on the housing displays the internal state of the converter the following way, see Table 1:

Table 1. Converter Status LED

| LED | Converter Status | Subsystem state | | Description |
|-------------------------------|---------------------------|---------------------------|----------------------|--|
| | | USB | CAN | |
| Green (steady or blinking) | Normal Operation | Configured | Normal Operation | USB port is configured. CAN port operates normally. It may not be configured yet. If blinking, CAN port is configured, and data is being transferred between CAN and USB ports. |
| Steady Yellow | USB Not Configured | Powered, Default, Address | Normal Operation | USB port is not configured. CAN port operates normally. <i>Check the driver installation if converter stays in this mode.</i> |
| Steady Red | CAN Error | Any | Communication Errors | There are communication errors on the CAN port. <i>Check the CAN port wiring, baud rate, terminating resistors.</i> |
| Steady Violet | CAN Low Power | Any | Any | CAN power supply voltage is low. The converter CAN communication can be unstable. This normally happens due to low USB voltage and an error condition on the CAN port. <i>Check the CAN port wiring. Plug the converter to a USB port with a better load capacity to maintain adequate CAN power supply voltage.</i> |
| Flashing Red | System Error ¹ | Any | Any | Unrecoverable system error. Device failure. Hardware or software error. |
| Alternate Green/Red | Bootloader Mode | Off | Off | The converter is in the Bootloader mode. |

| LED | Converter Status | Subsystem state | | Description |
|-------|------------------|-----------------|-----|---|
| | | USB | CAN | |
| | | | | USB port is disconnected from the host. CAN signal lines are at high impedance. The converter will go to the Bootloader mode for a short period of time to flash the new firmware uploaded through the USB port. It will leave the Bootloader mode automatically after the flashing operation is over. |
| Blank | Suspended | Suspended | Off | USB port is suspended. The converter is in the low power suspended state waiting to be woken up by the USB host. CAN signal lines are at high impedance. |
| | Power Off | Off | Off | Power off. USB port is disconnected from the host. CAN signal lines are at high impedance. |

¹ This status should not happen in normal conditions. *Try to perform a hardware reset by unplugging and then plugging back the USB port. Contact Axiomatic if this does not help.*

2.3 Firmware Organization

The converter internal firmware organization is straight forward, see Figure 2.

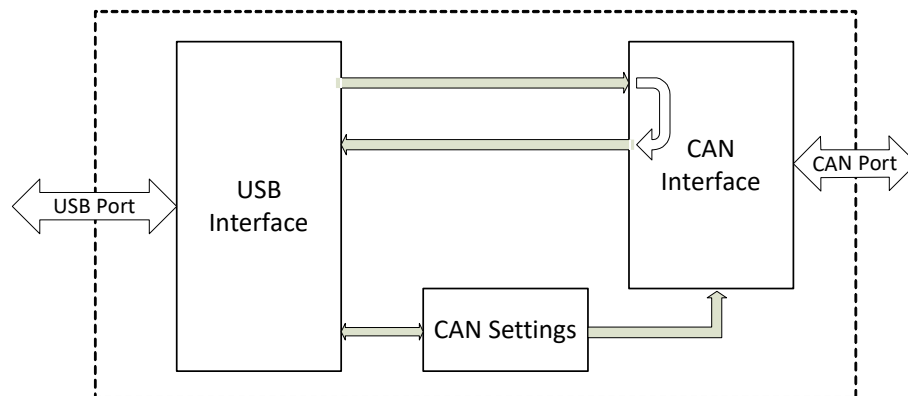

Figure 2. Firmware Internal Organization

All CAN messages received from USB port are route directly to CAN port. Once a message is sent from the CAN port, it is looped back to USB port to be counted as a received message from the CAN port. All CAN messages received from CAN port are route directly to USB port.

The converter is not configured on power up. The user should configure the converter by sending CAN Settings over the USB port to make the CAN port ready for communication. The details of the converter programming are provided in USB to CAN Converter SDK, p/n AX070501SDK.

2.4 CAN Bus Connection

The converter is connected to a CAN bus the following way.

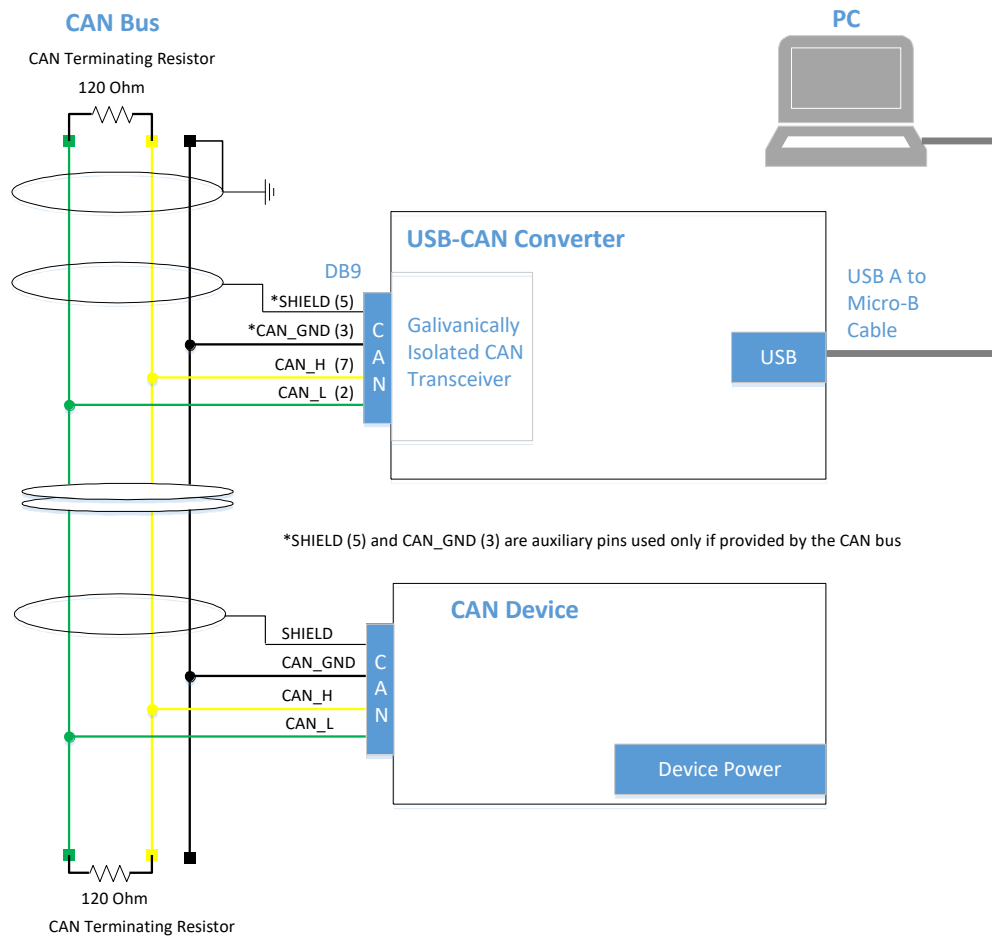

Figure 3. Connection to CAN bus

The CAN bus line contains a twisted differential signal pair CAN_H, CAN_L, and auxiliary CAN_GND and SHIELD conductors. CAN devices are connected to the bus line using short-length stubs. The twisted pair CAN_H, CAN_L is terminated on both sides with 120 Ohm resistors. In some cases, the terminating resistor can be embedded in the last CAN device connected directly to the bus line.

2.4.1 Workbench Connection

In case of a workbench connection, when space is limited and a dedicated CAN bus is not used, the user can directly connect CAN_H and CAN_L signals of a CAN device to CAN_H and CAN_L signals of the USB-CAN converter using a short (less than 1m) pair of wires. It is also necessary to connect at least one 120 Ohm resistor in parallel with CAN_H and CAN_L conductors for normal operation of CAN transceivers.

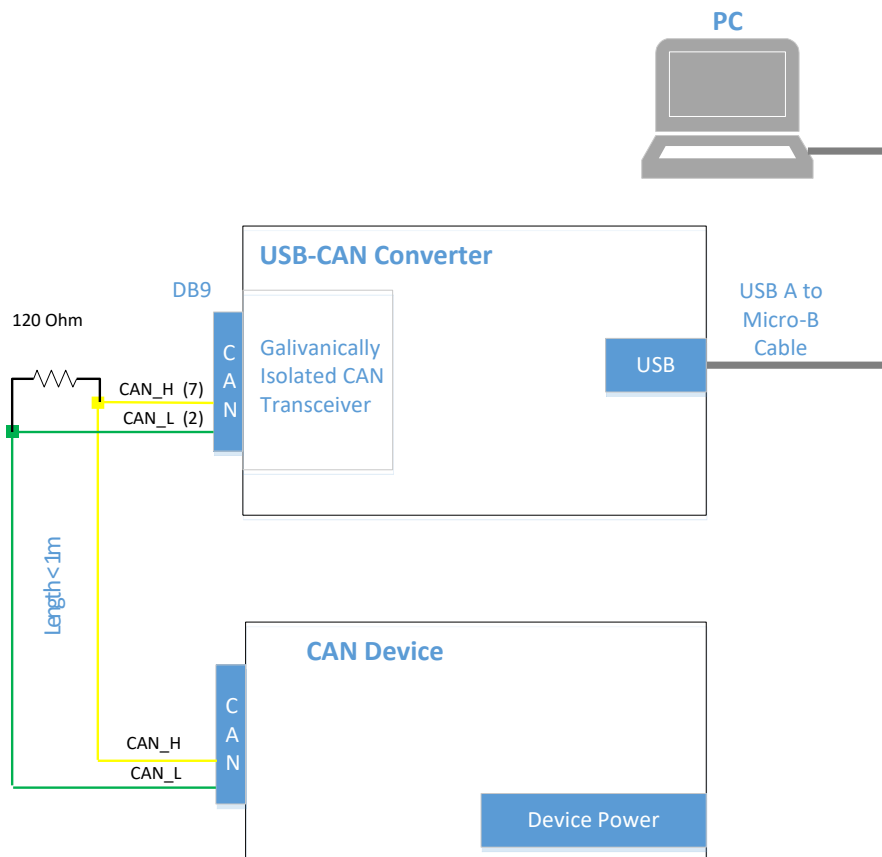

Figure 4. Workbench Connection

The user can extend this configuration, if necessary, by adding several CAN devices in parallel, provided that the summary length of CAN_H and CAN_L signal wires for all devices is kept short (less than 1m).

If longer wires are used, a standard CAN bus connection with two-side 120 Ohm termination is required, see Figure 3.

3 DRIVER INSTALLATION

To communicate with Windows software, the USB to CAN converter requires a driver. A zip file with Windows 32-bit and 64-bit driver package, p/n AX070504, can be downloaded from Axiomatic website www.axiomatic.com, *Support, EA & Other Configuration Tools* section, password: *trillium*.

After the zip file is downloaded, it should be unzipped at a temporary location on the user's PC.

The user should download the device driver package based on their Windows operating system.

Table 2. USB-CAN Driver Package

| Driver Package | Windows Operating System |
|--------------------------------------|--------------------------|
| USBCANDrivers, V1.2.0.0 | Win 7, 8.1, 10, 11 |
| USBCANDrivers, V1.1.0.1 (Deprecated) | Win 2000, XP, Vista |

Once the user plugs the USB to CAN converter in one of the USB PC ports, Windows will automatically recognize a new device and start a hardware installation wizard. The user should direct the wizard to the root folder of the unzipped driver package and check the *Include Subfolders* option.

After successful installation of the driver, USB LED on the front panel of the Axiomatic USB-CAN Converter will turn green, which means that the converter is ready for use.

3.1 Installation Example

The user should have administrative privileges on their PC account to install a driver. An example of the converter driver installation for Windows 11, is presented below.

1. Download and unzip the driver package from the Axiomatic website in a temporary ...*Downloads*\USBCANDriverv1.2.0.0 folder.
2. Unplug, wait ten seconds and then plug back in the USB cable of the USB-CAN Converter. The *LED* on the front panel of the converter should turn yellow.
3. Right click on *Start, Device Manager* and locate the *USBCAN Converter* in the *Other devices* group.

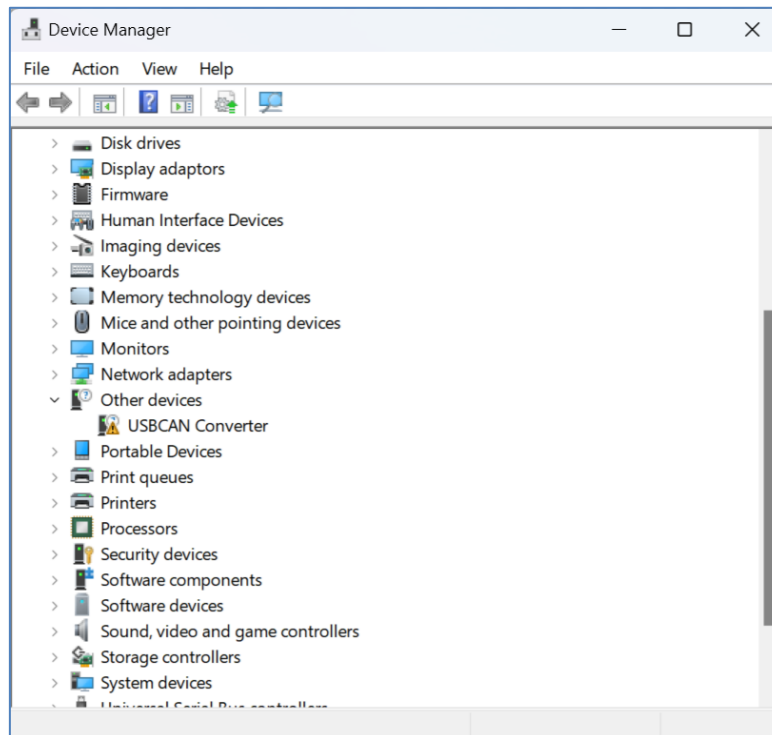

Figure 5. Driver Installation. Device Manager Screen

1. Double click on the *USBCAN Converter*. The Windows will open the *USBCAN Converter Properties* window.

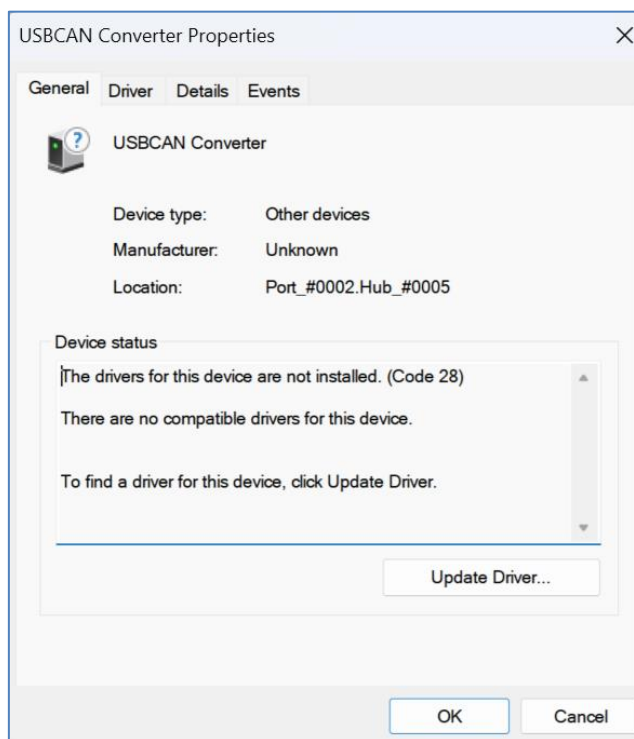

Figure 6. Driver Installation. USB-CAN Converter Properties Window

2. Click on *Update Driver...* button to launch the update driver wizard. The *Update Driver Software – USBCAN Converter* window will appear.

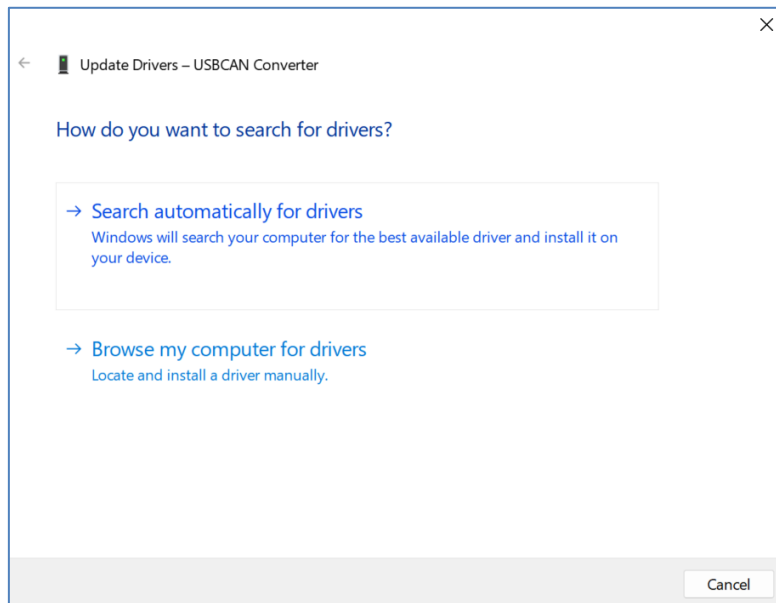

Figure 7. Driver Installation. Driver Installation Wizard Window

3. Click on *Browse my computer for drivers*. Go to the ...*Downloads\USBCANDriverV1.2.0.0* folder. Select *Include subfolders* option.

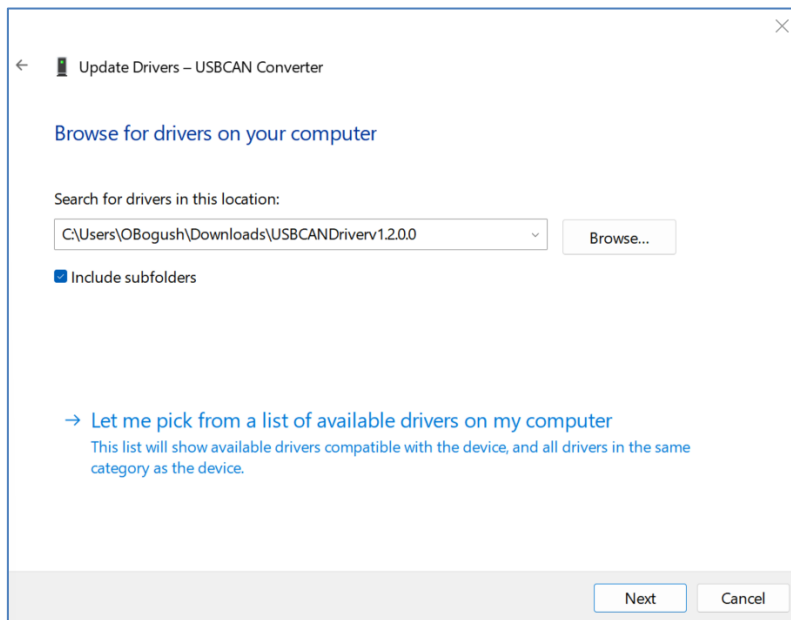

Figure 8. Driver Installation. Selecting the Driver Package

4. Press the *Next* button to install the driver. The following message should appear, telling the user that the driver installation was successful, see Figure 9.

The LED on the front panel of the USB-CAN Converter should turn green, indicating that the driver has been successfully installed, and the converter is ready for use.

In the older versions of Windows, when the driver V1.1.0.1 is used, a *Windows Security* window will pop-up asking whether the user trusts the device software from Axiomatic Technologies Corporation. The user should press the *Install* button to confirm the driver installation.

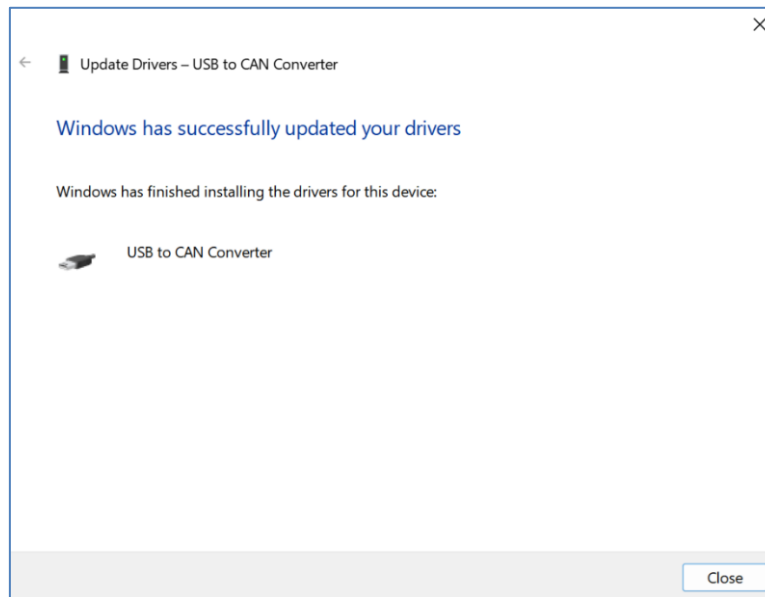

Figure 9. Driver Installation. Successful Installation Message

5. Press the *Close* button. Now, the user can delete the temporary folder with the driver package at `...\\Downloads\\USBCANDriverv1.2.0.0.`

4 FIRMWARE UPDATE

The converter firmware can be updated over the USB port using Axiomatic USB-CAN Converter Firmware Update Tool.

This software runs on any Windows PC starting from Windows XP and is available for download from Axiomatic website www.axiomatic.com.

The update procedure is performed in two stages. First, the application firmware is uploaded into the converter internal flash memory. During this stage, the converter checks the firmware checksum and whether it can be programmed into the unit.

Then, upon the user confirmation, the firmware is programmed into the converter internal memory and the unit is restarted to finalize the firmware update.

The details of the firmware update are provided below.

4.1 Connecting to Converter

To update the converter firmware, the user should connect the converter to any available USB port of the PC and then run the USB-CAN Converter Firmware Update Tool.

Then, in the upper-left part of the dialog window, the user should select the connected converter from the *Converter Name and State* drop-down list and then press the *Connect* button. The converter *Firmware ID* and *Firmware Version Number* will be displayed upon successful connection to the converter, see Figure 10.

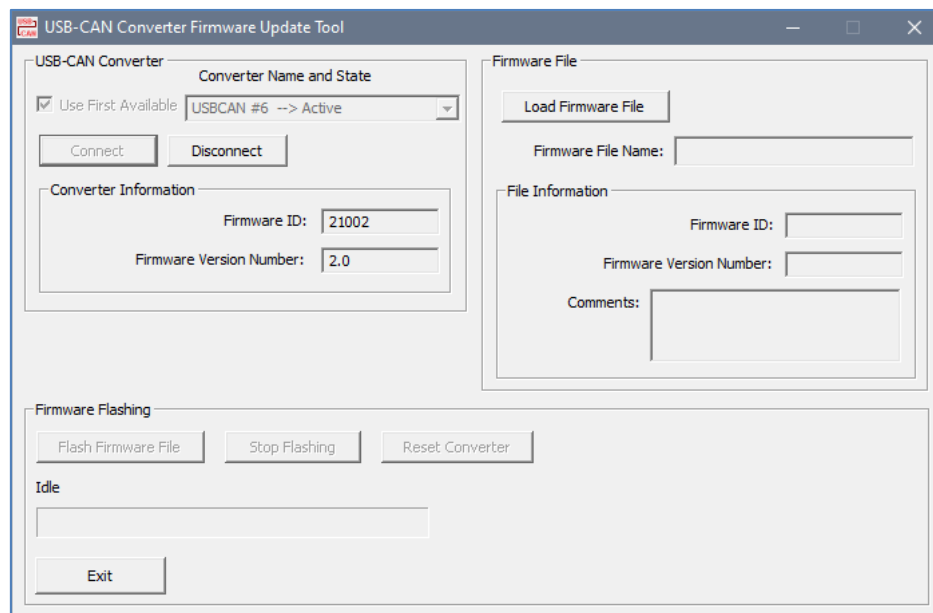

Figure 10. Firmware Update. Converter Is Connected

Please note, that the firmware update tool should be started after the converter is connected to the USB port, otherwise it will not appear on the list of the active converters.

4.2 Loading Firmware File

After connecting to the converter, the user loads the new firmware file by pressing *Load Firmware File* button in the *Firmware File* section of the dialog window, see Figure 11.

The file name should have the following format: `AF-21002-X.XX.af`, where the `<X.XX>` field wildcard reflects the firmware version number. We will use `AF-21002-2.00.af` file for illustration of the firmware update process in this manual re-flashing the already loaded firmware version 2.00.

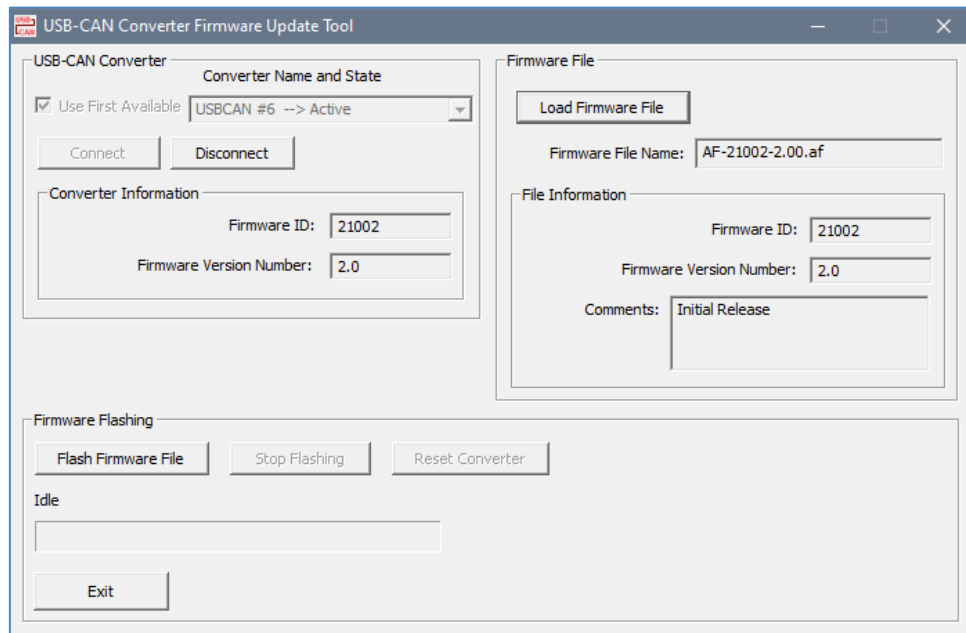

Figure 11. Firmware Update. Flash File is Loaded

The firmware file is loaded into the internal memory of the tool. The tool shows the *Firmware ID*, *Firmware Version Number* and *Comments* of the firmware from the loaded file.

The user can check this information before flashing the firmware into the converter internal memory.

4.3 Flashing Firmware

The user starts uploading the new firmware into the converter internal memory by pressing *Flash Firmware File* button, see Figure 12.

The progress of the flashing operation is shown in the progress bar. The user can stop flashing in the middle of the process by pressing the *Stop Flashing* button.

Once the flashing to the internal memory is over, the pop-up message will prompt the user to reset the converter to finalize the firmware update. In case of an error, an error message with the error code will appear.

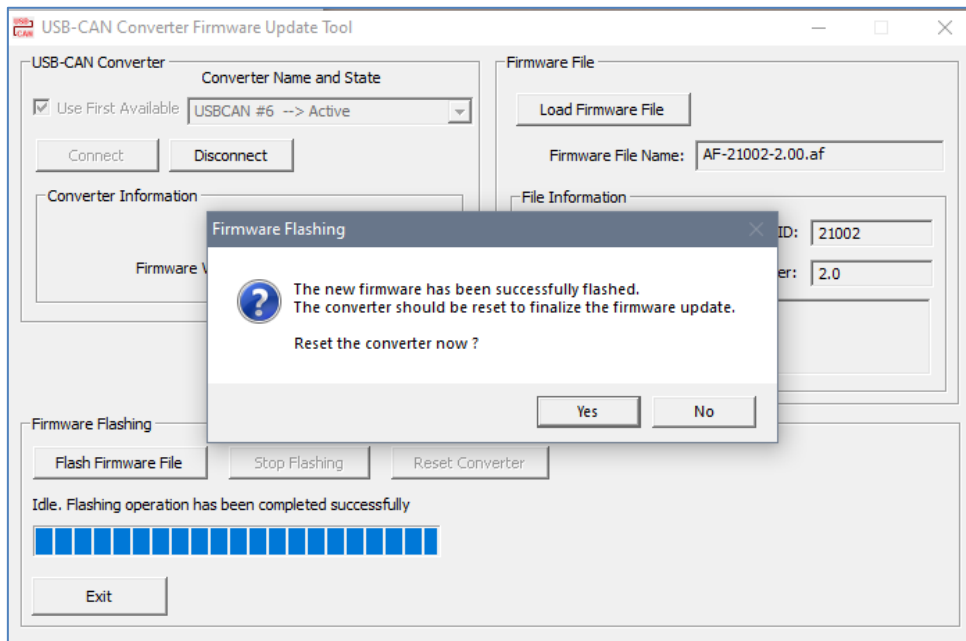

Figure 12. Firmware Update. New Firmware has been Flashed

4.4 Applying the New Firmware

To finalize the firmware update, the user should reset the converter. This will activate the bootloader that will flash the new firmware into the microcontroller memory. The following pop-up message will appear, see Figure 13.

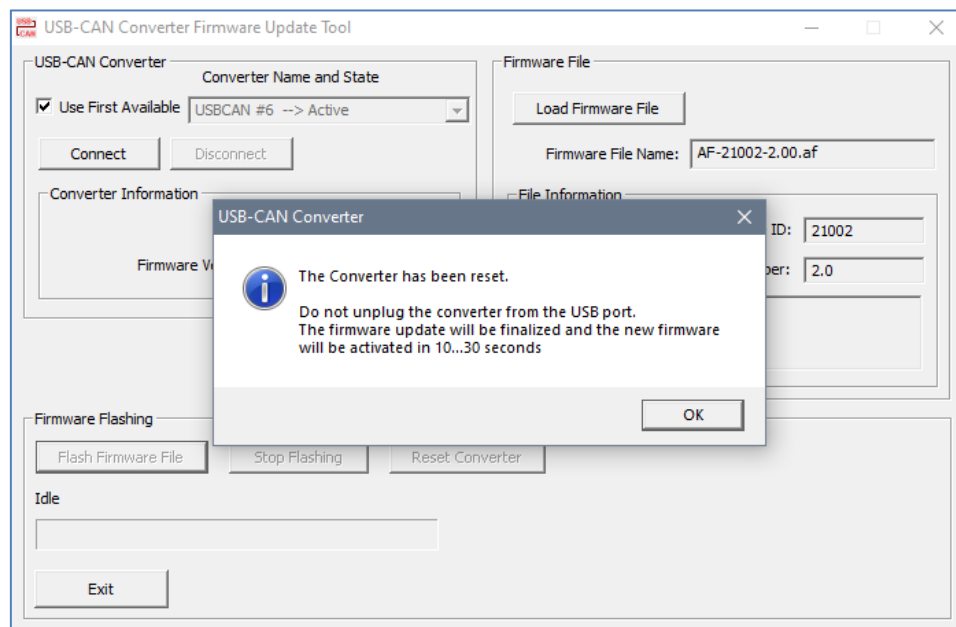

Figure 13. Firmware Update. Applying New Firmware

The USB connection will be lost for a short time (up to 30 seconds) and then the new firmware will automatically restore the connection with the user's PC at the end of the firmware update.

The user can check the new firmware version by pressing the *Connect* button of the firmware update tool after the new firmware has been activated.

5 TECHNICAL SPECIFICATIONS

5.1 USB Port

Table 3. USB Port Parameters

| Parameter | Value | Remarks |
|------------------------|--|---|
| USB Standard | USB 2.0 High-Speed (HS) or Full-Speed (FS) | Data rate: In HS - up to 480 Mb/s In FS - up to 12 Mb/s |
| Connector | USB 2.0 Micro-B receptacle | USB Micro device receptacle |
| Supply Voltage | 4.3...5.5V | 5V nominal. Provided by USB port |
| | 6V | Short-time overvoltage |
| Supply Current | 100 mA/300 mA | Current limit in Non-Configured/Configured state |
| | 150 mA | Maximum steady current in Configured state at 5V |
| | 2.5 mA | Maximum current in Suspended state at 5V |
| ESD Protection | ± 8 kV / ± 15 kV | IEC 61000-4-2, Contact / Air, Data lines |
| | ± 30 kV | IEC 61000-4-2, Contact, Power lines |
| Communication Protocol | Proprietary | Supported by Axiomatic Electronic Assistant (EA) suit. Windows Drivers and SDK are provided |

5.2 CAN Port

Table 4. CAN Port Parameters

| Parameter | Value | Remarks |
|---------------------------|--|--|
| Number of Ports | 1 | Galvanically Isolated |
| Port Isolation | 400 VAC 3 kV DC | Functional Isolation, IEC 60950-1 Isolation Withstand Voltage, 1 minute |
| ESD Protection | ± 15 kV | IEC 61000-4-2, Contact |
| Maximum Bus Fault Voltage | ± 32 V | Maximum steady-state voltage on the CAN bus the transceiver can tolerate |
| Common Voltage | ± 30 V | Maximum receiver common mode input voltage |
| Connector | 9-pin D-sub (DB9), Male | DIN 41652, IEC 60807-3 |
| Pinout | CANopen | CIA 303-1 |
| Port Type | High Speed, ISO 11898-2 compatible | Connected to 120Ohm terminated twisted pair, baud rate up to 1 Mbit/s. External 120Ohm terminating resistor is required. Shield connection is provided if shielded cable is used |
| Baud Rate | 1000, 800, 667, 500, 250, 125, 100, 50, 20, 10 or a custom value | [kbit/s] |
| Protocol | CAN Bosch 2.0A and B | Data Frames and Remote Frames with Standard and Extended IDs are supported |

5.3 LED Indicator

A three-color RGB LED indicator on the front side of the housing displays the current status of the converter.

5.4 General Specifications

Table 5. General Specifications

| Parameter | Value | Remarks |
|--------------------------|---|--|
| Operating Temperature | -40...+85 °C | Industrial temperature range |
| Environmental Protection | IP40 | IEC 60529 |
| Size | 4.62 in x 3.11 in x 0.98 in (117 mm x 79 mm x 25 mm) | L x W x H excluding DB-9 connector. See dimensional drawing |
| Weight | 0.30 lbs (0.136 kg) | |
| Compliance | RoHS Directive | CE, FCC – to be added |

5.5 Software

The following Windows software is used together with the USB to CAN converter and available for download from Axiomatic website www.axiomatic.com.

| Axiomatic P/N | Description |
|---------------|--|
| AX070504 | USBCANDrivers, USB-CAN Converter Drivers |
| AX070505UT | USB-CAN Converter Firmware Update Tool |
| AX070501SDK | USB-CAN Converter SDK (Software Development Kit) |

5.6 Accessories

Table 6. Accessories

| Axiomatic P/N | Description | | | | | | |
|---------------------------|---|----------------|-------|-------------------|-------|-------|---------|
| CBL-USB2.0A-MICROB-0.9M | Generic USB 2.0 A to Micro-B Cable, 3ft (0.9m) | | | | | | |
| CAB-AX070501 ¹ | <p>Temporary CAN connection cable.</p> <p>A cable with a female DB-9 connector and three loose CAN wires, 12 inches (30 cm) long. Wires have the following marking:</p> <table border="1" data-bbox="630 1199 1117 1308"> <tbody> <tr> <td>Green (or Red)</td> <td>CAN_L</td> </tr> <tr> <td>Yellow (or White)</td> <td>CAN_H</td> </tr> <tr> <td>Black</td> <td>CAN_GND</td> </tr> </tbody> </table> | Green (or Red) | CAN_L | Yellow (or White) | CAN_H | Black | CAN_GND |
| Green (or Red) | CAN_L | | | | | | |
| Yellow (or White) | CAN_H | | | | | | |
| Black | CAN_GND | | | | | | |

¹CAB-AX070501 is provided for evaluation purposes only. The user is responsible for connecting the converter to the CAN network using a reliable wire harness with electrical parameters compatible with the CAN network.

5.7 CAN Connector

Standard 9-pin, D-sub (DB9), male connector.

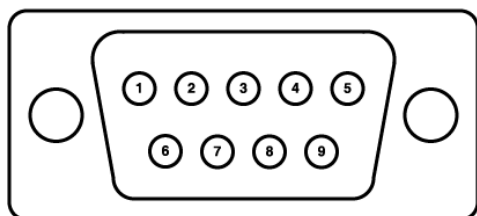

Table 7. Converter Pinout

| Pin # | Description |
|---------------|---------------|
| 7 | CAN_H |
| 2 | CAN_L |
| 3 | CAN_GND |
| 5 | CAN_SHIELD |
| 1, 4, 6, 8, 9 | Not Connected |

5.8 Housing

ABS Plastic enclosure. Flame Rating UL94-V-0. For dimensional drawing, see Figure 14.

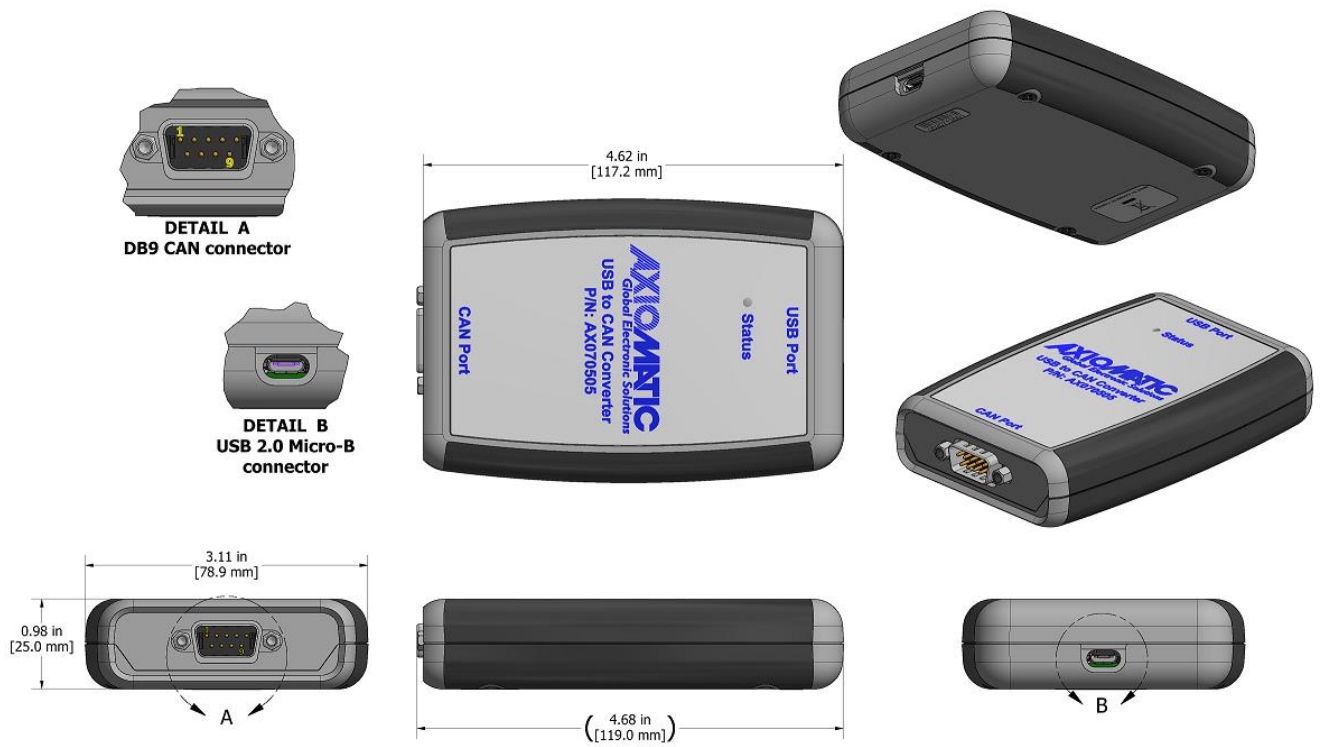

Figure 14. Dimensional Drawing

6 VERSION HISTORY

| User Manual Version | Firmware version | Date | Author | Modifications |
|---------------------|------------------|-------------------|-------------|--|
| 2D | 2.xx | February 21, 2024 | Olek Bogush | <ul style="list-style-type: none">• Updated <i>Driver Installation</i> section.• Added Axiomatic p/n to the USB-CAN converter driver package in <i>Technical Specifications, Software</i> subsection. |
| 2C | 2.xx | January 9, 2024 | M Ejaz | <ul style="list-style-type: none">• Address change |
| 2B | 2.xx | May 9, 2022 | Olek Bogush | <ul style="list-style-type: none">• Updated <i>Driver Installation</i> section with information on how to disable HVCI. |
| 2A | 2.xx | April 25, 2022 | Olek Bogush | <ul style="list-style-type: none">• Defined <i>Weight</i> in <i>General Specifications</i>.• Added <i>CAN Bus Connection</i> section. |
| 2 | 2.xx | April 20, 2022 | Olek Bogush | <ul style="list-style-type: none">• Initial release. Version numbering continues from AX070501. |

OUR PRODUCTS

AC/DC Power Supplies
Actuator Controls/Interfaces
Automotive Ethernet Interfaces
Battery Chargers
CAN Controls, Routers, Repeaters
CAN/WiFi, CAN/Bluetooth, Routers
Current/Voltage/PWM Converters
DC/DC Power Converters
Engine Temperature Scanners
Ethernet/CAN Converters,
Gateways, Switches
Fan Drive Controllers
Gateways, CAN/Modbus, RS-232
Gyroscopes, Inclinometers
Hydraulic Valve Controllers
Inclinometers, Triaxial
I/O Controls
LVDT Signal Converters
Machine Controls
Modbus, RS-422, RS-485 Controls
Motor Controls, Inverters
Power Supplies, DC/DC, AC/DC
PWM Signal Converters/Isolators
Resolver Signal Conditioners
Service Tools
Signal Conditioners, Converters
Strain Gauge CAN Controls
Surge Suppressors

OUR COMPANY

Axiomatic provides electronic machine control components to the off-highway, commercial vehicle, electric vehicle, power generator set, material handling, renewable energy and industrial OEM markets. ***We innovate with engineered and off-the-shelf machine controls that add value for our customers.***

QUALITY DESIGN AND MANUFACTURING

We have an ISO9001:2015 registered design/manufacturing facility in Canada.

WARRANTY, APPLICATION APPROVALS/LIMITATIONS

Axiomatic Technologies Corporation reserves the right to make corrections, modifications, enhancements, improvements, and other changes to its products and services at any time and to discontinue any product or service without notice. Customers should obtain the latest relevant information before placing orders and should verify that such information is current and complete. Users should satisfy themselves that the product is suitable for use in the intended application. All our products carry a limited warranty against defects in material and workmanship. Please refer to our Warranty, Application Approvals/Limitations and Return Materials Process at <https://www.axiomatic.com/service/>.

COMPLIANCE

Product compliance details can be found in the product literature and/or on axiomatic.com. Any inquiries should be sent to sales@axiomatic.com.

SAFE USE

All products should be serviced by Axiomatic. Do not open the product and perform the service yourself.



This product can expose you to chemicals which are known in the State of California, USA to cause cancer and reproductive harm. For more information go to www.P65Warnings.ca.gov.

SERVICE

All products to be returned to Axiomatic require a Return Materials Authorization Number (RMA#) from rma@axiomatic.com. Please provide the following information when requesting an RMA number:

- Serial number, part number
- Runtime hours, description of problem
- Wiring set up diagram, application and other comments as needed

DISPOSAL

Axiomatic products are electronic waste. Please follow your local environmental waste and recycling laws, regulations and policies for safe disposal or recycling of electronic waste.

CONTACTS

Axiomatic Technologies Corporation
1445 Courtneypark Drive E.
Mississauga, ON
CANADA L5T 2E3
TEL: +1 905 602 9270
FAX: +1 905 602 9279
www.axiomatic.com
sales@axiomatic.com

Axiomatic Technologies Oy
Höytämöntie 6
33880 Lempäälä
FINLAND
TEL: +358 103 375 750
www.axiomatic.com
salesfinland@axiomatic.com