



USER MANUAL UMAX022310
Version 2C

**DUAL 2.5A OUTPUT
PLUG-IN
VALVE CONTROLLER**
with Programmable Logic, CAN SAE J1939

USER MANUAL

P/N: AX022310

Axiomatic Technologies Oy
Höytämöntie 6
33880 LEMPÄÄLÄ, Finland
Tel. +358 103 375 750
salesfinland@axiomatic.com
www.axiomatic.fi

Axiomatic Technologies Corporation
1445 Courtneypark Dr. E.
Mississauga, ON Canada L5T 2E3
Tel. 1 905 602 9270
sales@axiomatic.com
www.axiomatic.com

ACCRONYMS

ACK	Positive Acknowledgement (from SAE J1939 standard)
DM	Diagnostic Message (from SAE J1939 standard)
DOUT	Digital Output, sourcing (high-side) output up to 2.5A current
DTC	Diagnostic Trouble Code (from SAE J1939 standard)
EA	The Axiomatic Electronic Assistant (A Service Tool for Axiomatic ECUs)
ECU	Electronic Control Unit (from SAE J1939 standard)
NAK	Negative Acknowledgement (from SAE J1939 standard)
PDU1	A format for messages that are to be sent to a destination address, either specific or global (from SAE J1939 standard)
PDU2	A format used to send information that has been labeled using the Group Extension technique, and does not contain a destination address.
PGN	Parameter Group Number (from SAE J1939 standard)
PropA	Message that uses the Proprietary A PGN for peer-to-peer communication
PropB	Message that uses a Proprietary B PGN for broadcast communication
PWM	Pulse Width Modulation
RPM	Rotations per Minute
SPN	Suspect Parameter Number (from SAE J1939 standard)
UOUT	Universal Output, 0-2.5A current, digital, voltage or PWM type

Note:

An Axiomatic Electronic Assistant KIT may be ordered as P/N: AX070502 or AX070506K

TABLE OF CONTENTS

1. OVERVIEW OF CONTROLLER.....	6
1.1. Description of Valve Controller.....	6
1.2. Output Functions Blocks.....	9
1.3. PID Control Function Block.....	17
1.4. Lookup Table Function Block.....	19
1.5. Programmable Logic Function Block.....	26
1.6. Math Function Block.....	32
1.7. Diagnostic Function Block.....	34
1.8. DTC React Function Block.....	37
1.9. CAN Transmit Message Function Block.....	38
1.10. CAN Receive Message Function Block.....	40
1.11. Available Control/Input Sources.....	42
1.12. Default Valve Controller Program Logic.....	43
2. INSTALLATION INSTRUCTIONS.....	44
2.1. Dimensions and Pinout.....	44
2.2. Mounting Instructions	45
3. OVERVIEW OF J1939 FEATURES.....	47
3.1. Introduction to Supported Messages.....	47
3.2. NAME, Address and Software ID.....	48
3.3. CAN Transmit Messages Defaults.....	50
3.4. CAN Receive Messages Defaults.....	51
4. ECU SETPOINTS ACCESSED WITH THE AXIOMATIC EA.....	52
4.1. Miscellaneous Setpoints.....	53
4.2. Output Drive Setpoints.....	54
4.3. Constant Data List Setpoints.....	56
4.4. PID Control Setpoints.....	57
4.5. Lookup Table Setpoints.....	58
4.6. Programmable Logic Setpoints.....	59
4.7. Math Function Setpoints.....	60
4.8. CAN Transmit Setpoints.....	61
4.9. CAN Receive Setpoints.....	62
4.10. DTC React Setpoints.....	63
4.11. [Additional] Diagnostic Setpoints.....	63
5. REFLASHING OVER CAN WITH THE AXIOMATIC EA BOOTLOADER.....	65
6. DEFAULT DIAGNOSTIC TROUBLE CODE TABLE.....	70
7. TECHNICAL SPECIFICATIONS.....	71
8. VERSION HISTORY.....	73

LIST OF FIGURES

1A. Hardware Functional Block Diagram.....	6
1B. Logical Functional Block Diagram.....	8
2. Output Control Function Block.....	9
3. Linear Slope Calculations.....	9
4. Output Logic Flowchart.....	11
5. Output Drive Function Block.....	12

6. PWM Outputs with Linked Response.....	13
7. Analog to Digital Input.....	13
8. Hotshot Digital Profile.....	14
9. PID Control Function Block.....	17
10. PID Control Algorithm.....	18
11. Lookup Table Function Block	19
12. Lookup Table Default Initialization Examples.....	22
13. Lookup Table “Jump To” Data Response.....	22
14. Lookup Table Examples to Setup for Joystick Deadband Response.....	23
15. Lookup Table Time Response Clutch Fill Profiles.....	24
16. Lookup Table “Soft Shift” Axiomatic EA Configuration.....	25
17. Programmable Logic Function Block	26
18. Programmable Logic Flowchart.....	28
19. Math Function Block.....	32
20. Diagnostics Function Block.....	34
21. DTC React Function Block.....	37
22. CAN Transmit Function Block.....	38
23. CAN Receive Function Block.....	40
24. Default Control Logic.....	43
25. Dimension Drawing.....	44
26. De-rating Curve.....	71

LIST OF TABLES

1. Enable Response Options.....	10
2. Fault Response Options.....	10
3. Output Type Options.....	12
4. Digital Response Options.....	13
5. PID Responses.....	17
6. Conditional Operator Options.....	29
7. Condition Evaluation Results.....	29
8. Conditions Logical Operator Options.....	30
9. Conditions Evaluation Based on Selected Logical Operator.....	30
10. Programmable Logic Block Default Lookup Tables.....	31
11. Math Function Operators.....	33
12. Fault Detect Thresholds.....	35
13. Low Fault FMI versus High Fault FMI.....	37
14. Default CAN Transmit Messages.....	39
15. Default CAN Receive Messages.....	41
16. Programmable Inputs.....	42
17. Input Sources and Numbers.....	43
18. Connector Pinout.....	44

REFERENCES

J1939	Recommended Practice for a Serial Control and Communications Vehicle Network, SAE, April 2011
J1939/21	Data Link Layer, SAE, December 2010
J1939/71	Vehicle Application Layer, SAE, March 2011
J1939/73	Application Layer-Diagnostics, SAE, February 2010
J1939/81	Network Management, SAE, May 2003
TDAX022310	Technical Datasheet, Dual Input, Dual Output Valve Controller
UMAX07050x	User Manual V4.5.49, Axiomatic Electronic Assistant and USB-CAN, Axiomatic Technologies, August 2023

This document assumes the reader is familiar with the SAE J1939 standard. Terminology from the standard is used, but is not described in this document.



NOTE: This product is supported by Axiomatic Electronic Assistant V4.5.49.1 and higher



NOTE: When a description is in “**double-quotes**” and bolded, this refers to the name of a user configurable setpoint (variable). If it is in ‘*single-quotes*’ and italicized, it refers to an option for the associated setpoint.

For example: “**Output Type**” set to ‘*Proportional Current*’



This product uses the Axiomatic Electronic Assistant to program the setpoints for application specific requirements. After configuration, the setpoints can be saved in a file which could then be flashed into other AX022310 controllers over the CAN network.

One point to note is that if the setpoint “**Auto update when control changes**” is set to TRUE in the file, the controller will automatically update some setpoints to new defaults when key setpoints are changed. This is a useful feature during configuration, but during a setpoint file upload it may be required to reflash the same file a second time if this feature is active. The second upload will ensure all setpoints are correctly updated, since some of them may have been automatically overwritten during the first reflashing process, and therefore don’t match the values in the file.

To avoid this potential problem, it is HIGHLY recommended by Axiomatic to always set the “**Auto update when control changes**” setpoint to FALSE before saving a setpoint file, so that it all setpoints will be set as expected on the first upload.

1. OVERVIEW OF CONTROLLER

1.1. Description of Valve Controller

The Dual Output Plug-In Valve (2oPi) is designed for extremely versatile control of up to two proportional outputs to directly drive coils or other loads from the CAN network. Its flexible circuit design gives the user a wide range of configurable output types. The sophisticated control algorithms allow the user to program the controller for a wide range of applications without the need for custom software. The J1939 CAN network can operate at standard 250 kbit/s and 500kbit/s and non-standard 667kbit/s and 1Mbit/s baud rates with automatic baud rate detection.

There are two universal outputs that can be setup to drive: proportional current (up to 2.5A each); hotshot digital current; proportional voltage (up to supply); proportional PWM; or straight on/off digital loads. The outputs are independent from one another, unless specifically noted otherwise in this document.

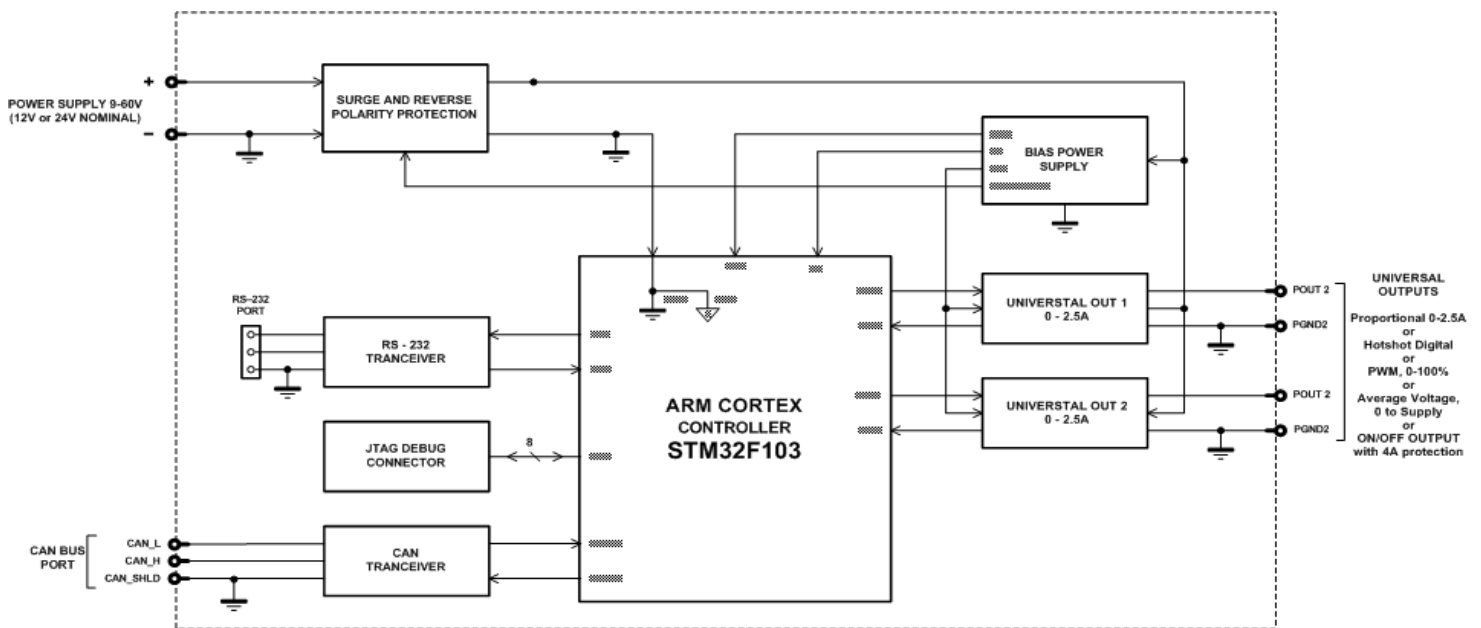

Figure 1A – Hardware Functional Block Diagram

The 2oPi is a highly programmable controller, allowing the user to configure it for their application. It must be integrated into a CAN J1939 network of controllers. Its sophisticated control algorithms allow for open or closed loop drive of the proportional outputs. All logical function blocks on the unit are inherently independent from one another, but can be programmed to interact in a large number of ways. While Figure 1A shows the hardware features, Figure 1B shows the logical function blocks (software) available on the 2oPi.

The 2oPi has a number of built-in protection features that can shut off the outputs in adverse conditions. These features are described in detail in section 1.7 Table 12 and they include hardware shutoffs to protect the circuits from being damaged as well as software shutdown features that can be enabled in safety critical systems.

The various function blocks supported by the 2oPi are outlined in the following sections. All setpoints are user configurable using the Axiomatic Electronic Assistant, as outlined in Section 4 of this document.

- Yellow bubbles represent setpoints that are unique to the function block in question
- Green bubbles represent the inputs to the function block
- Grey (light purple) bubbles represent outputs from the function block that can be mapped as inputs to other function blocks
- Blue bubbles represent another function block supported by the ECU which is intrinsically linked to the function block in question.
- Red bubbles represent outputs from the function block that are used internally in the controller by other function blocks, but are not accessible to the user.
- Dark purple bubbles represent messages that are sent to or received from the CAN bus.

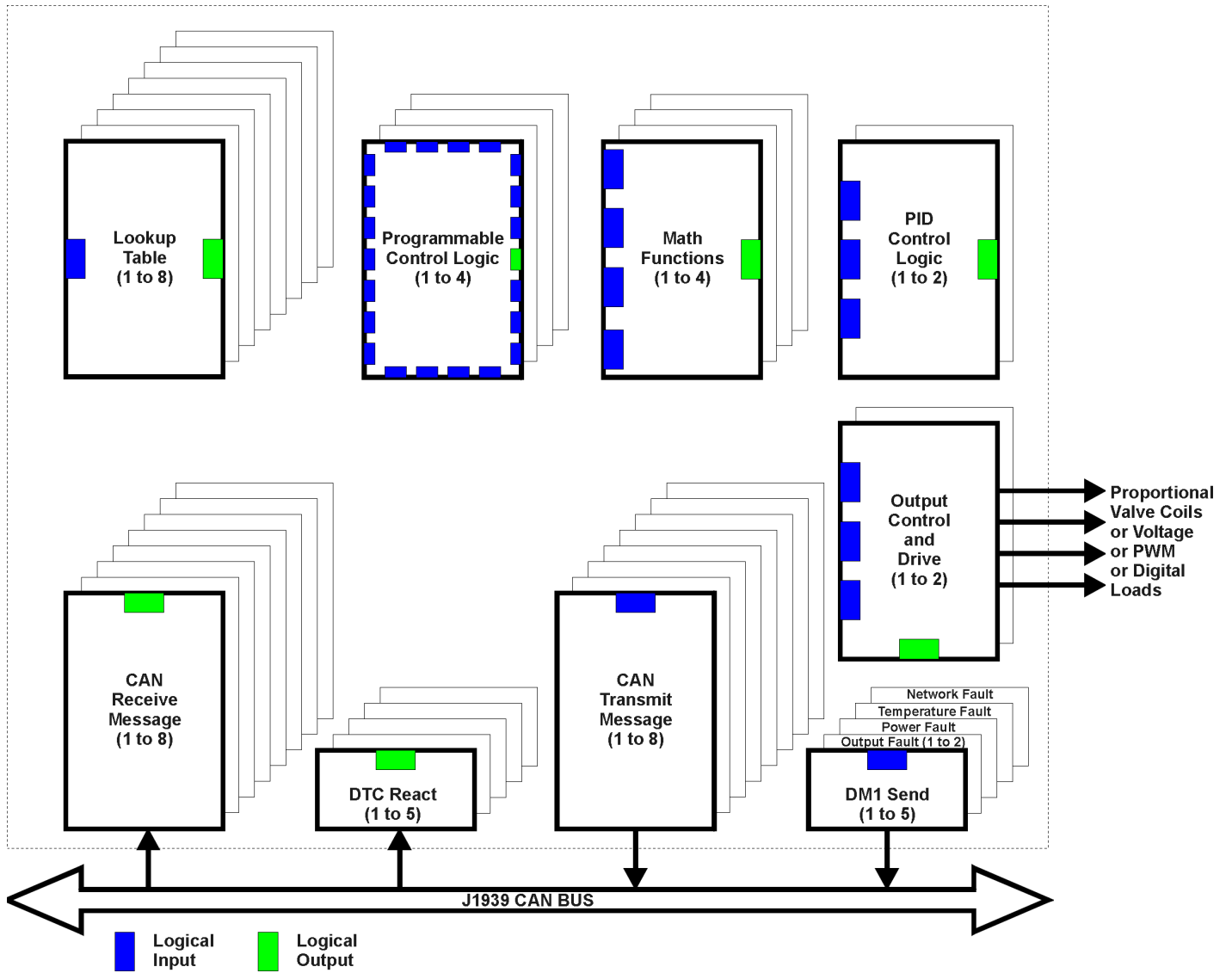

Figure 1B –Logical Functional Block Diagram

1.2. Output Function Blocks

There are two types of output function blocks, one for proportional output drive and the other for output control. While both types of function blocks are found in the “**Output X Drive**” setpoint list, they are treated as separate function blocks here for ease of explanation.

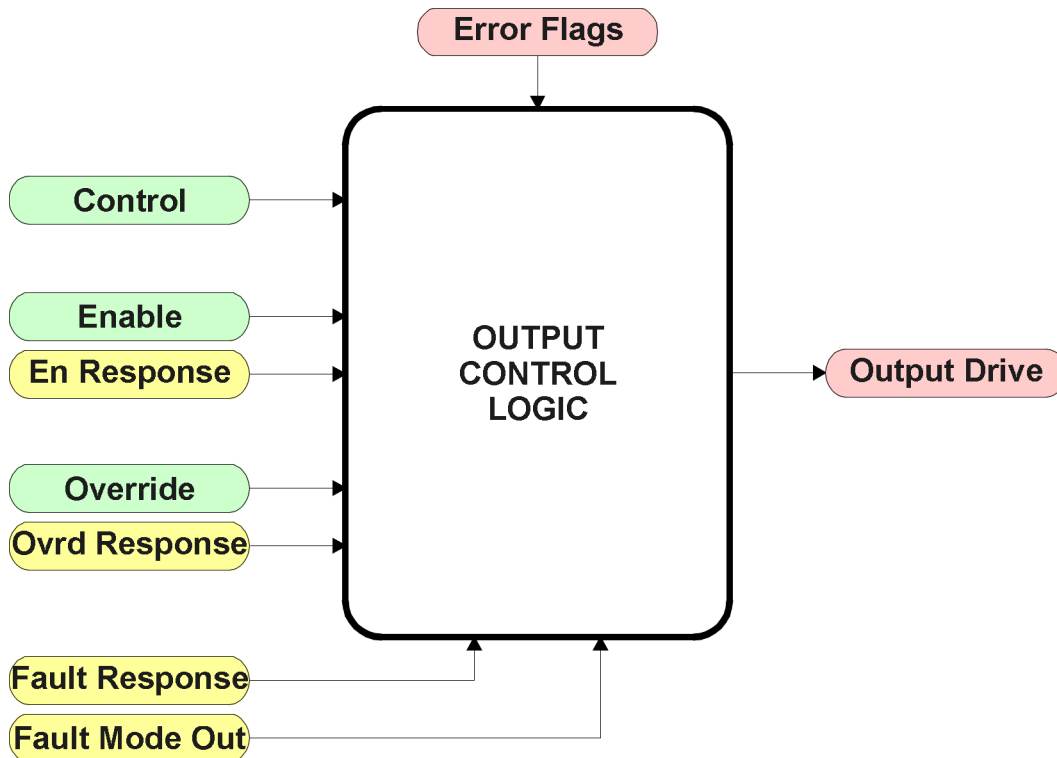

Figure 2 – Output Control Function Block

The Output Control Logic and the Output Drive function blocks are linked. The control signal, (whether from a CAN command, a Lookup Table, or a Logic, Math or PID block) will have associate with it a minimum and maximum value. Regardless of what type of control input is selected, the output will always respond in a linear fashion to changes in the input per the calculation in Figure 3.

$$y = mx + a$$

$$m = \frac{Y_{\max} - Y_{\min}}{X_{\max} - X_{\min}}$$

$$a = Y_{\min} - m * X_{\min}$$

Figure 3 – Linear Slope Calculations

In the case of the Output Control Logic function block, X and Y are defined as

Xmin = Control Input Minimum
Xmax = Control Input Maximum

Ymin = “**Output at Minimum Command**”
Ymax = “**Output at Maximum Command**”

In all cases, while the X-axis has the constraint that $X_{min} < X_{max}$, there is no such limitation on the Y-axis. This allows for a negative slope so that as the control input signal increases, the target output value decreases.

By default, the Output X “**Control Source**” is setup to be ‘*Received CAN J1939 Message.*’ In other words, all the proportional outputs will response in a linear fashion the corresponding command data. (i.e. Received Message 1 controls Output 1) For a non-linear response, the Control should be mapped to ‘*Lookup Table X*’ instead.

In addition to the Control input, the function block also supports an enable input which can be setup as either an enable or disable signal. If multiple enable/disable inputs are required, select the “**Enable Source**” to be the ‘*Math Function Block*’, and setup the desired logic response as described in Section 1.6.

When an Enable input is used, the output will be shutoff as per the “**Enable Response**”. If the response is selected as a disable signal (2 or 3), when the input is ON, the output will be shutoff.

0	<i>Enable When On, Else Shutoff</i>
1	<i>Enable When On, Else Rampoff</i>
2	<i>Enable When Off, Else Shutoff</i>
3	<i>Enable When Off, Else Rampoff</i>
4	<i>Enable When On, Else Ramp To Min</i>
5	<i>Enable When On, Else Ramp To Max</i>

Table 1 – Enable Response Options

A useful feature of the Enable input is that it can be mapped to react to a diagnostic trouble code (DTC) sent by another ECU on the network via a DM1. In this case, the “**Enable Source**” would be a ‘*Diagnostic Trouble Code (Rxd)*’, and the response would be setup as a disable signal.

The Override option allows the user to have the output drive go to a default value in the case of the override input being engaged/disengaged, depending on the logic selected in “**Override Response.**” When active, the output will be driven to the value in “**Output at Override Command**” regardless of the value of the Control input.

The Enable and Override commands can be mapped to either a CAN message or any other input. By default the 2oPi assumes a digital input will be used for all of these inputs. If a non-digital control is selected, the input will be interpreted per the hysteresis logic shown in Figure 7.

If a fault is detected at any active input (Enable/Override/Control), then the output will respond per the “**Control Fault Response**” setpoint as outlined in Table 2. This is also true when controlled by a CAN message that is not received within the expected update timeframe (lost communication error). Should a fault response occur the output drive will remain in the corresponding state until the condition(s) causing the fault reaction has disappeared.

0	<i>Shutoff Output</i>
1	<i>Apply Fault Value</i>
2	<i>Hold Last Value</i>

Table 2 – Fault Response Options

Another fault response that can be enabled is that a power supply over voltage or under voltage will automatically disable ALL outputs. Note: this setpoint is associated with the **Power Supply Diag** function block. Also, if the **Over Temperature Diag** function block is enabled, then a microprocessor over-temperature reading disables all the outputs until it has cooled back to the operating range.

Fault conditions are checked for first, and only if they are not present are the control signal then evaluated. If Enable, Override and Control inputs are all used, the Enable logic is evaluated first, then the Override, and lastly the Control. The logic flow chart for evaluating the output drive is shown in Figure 4 below.

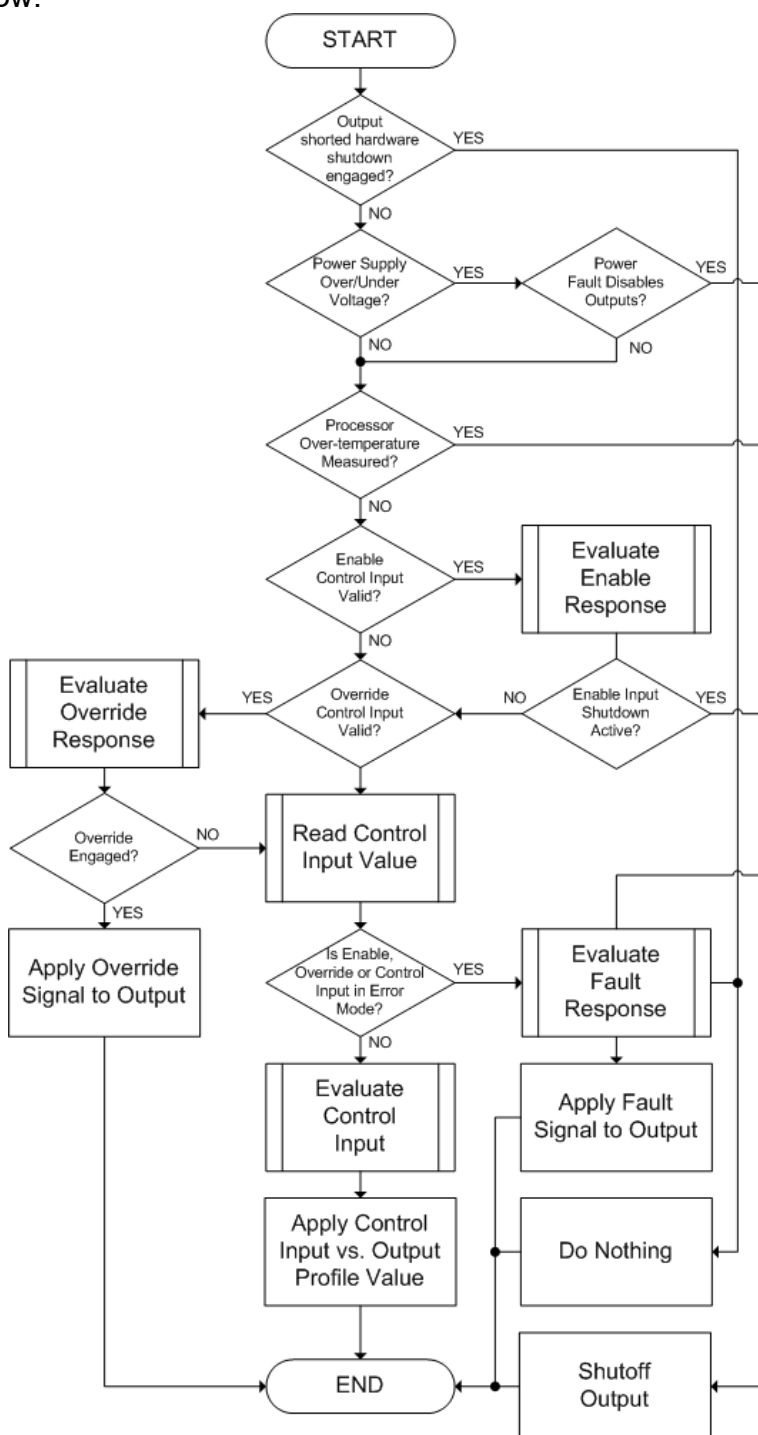

Figure 4 – Output Logic Flowchart

The other type of function block associated with an output is the drive block itself, as shown in Figure 5.

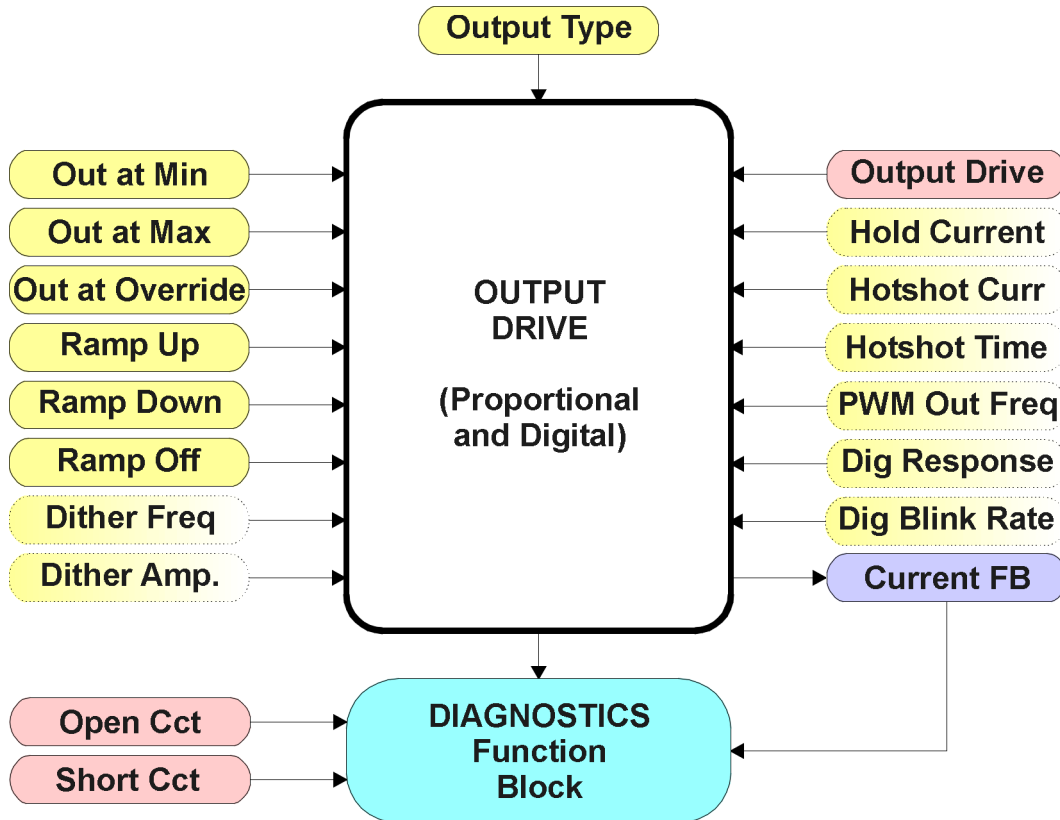

Figure 5 – Output Drive Function Block

The “**Output Type**” is the most important setpoint associated with this function block, and it should be selected first. Changing it will result in other setpoints being automatically updated by the 2oPi to match the new type. There are several output types supported, as outlined in Table 3.

0	<i>Disabled</i>
1	<i>Proportional Current</i>
2	<i>Digital Hotshot</i>
3	<i>PWM Duty Cycle</i>
4	<i>Proportional Voltage</i>
5	<i>Digital On/Off</i>

Table 3 – Output Type Options

For the ‘*Proportional Current*’ or ‘*Hotshot Digital*’ types, the unit for the output values is mA, and the Diagnostic function block, related to the current feedback, is used. For all other output types, the output fault detection/reaction setpoints are ignored.

Any of the proportional responses (current, duty cycle or voltage) react to the Control input in a linear fashion per the relationship in Figure 2.

In order to prevent abrupt changes at the output due to sudden changes in the command input, the user can choose to use the independent up or down ramps to smooth out the coil's response. The **"Ramp Up"** and **"Ramp Down"** setpoints are in milliseconds, and the step size of the output change will be determined by taking the absolute value of the output range and dividing it by the ramp time.



If the output is being controlled by a Lookup Table function block in the "Time Response" mode, the user should disable the output drive ramps (set them to zero) as the table will already ramp the command before it is applied to the output drive.

The *'Proportional Current'* type has associated with it two setpoints not used by the other types, which are the **"Dither Frequency"** and **"Dither Amplitude"** values. The output is controlled by a high frequency signal (25kHz), with the low frequency dither superimposed on top. ***The same dither frequency is applied to both outputs.***

The dither frequency will match exactly what is programmed into the setpoint, but the exact amplitude of the dither will depend on the properties of the coil. When adjusting the dither amplitude value, select one that is high enough to ensure an immediate response to the coil to small changes in the control inputs, but not so large as to affect the accuracy or stability of the output. Refer to the coil's datasheet for more information.

The *'Proportional Voltage'* type uses the measured value of the power supply, and adjusts the duty cycle of the output such that the average value will match the target output voltage. Since the output is normally running at a high frequency (25kHz), the voltage can be easily average using a simple low pass filter.

Normally, the *'PWM Duty Cycle'* option allows the user to run the output at a fixed frequency (i.e. 500Hz) while the duty cycle changes depending on the Control input. However, since the PWM peripheral for the drive is used by both outputs, the output frequency for this output type remains fixed at 25kHz if either output is setup for current control. In this case, there is not much difference between the Voltage or PWM outputs in the product.

If and only if both outputs are setup for PWM, Voltage or Digital On/Off will the setpoint **"PWM Output Frequency"** on be selectable in the Output 1 Drive group. ***In all case, the same output frequency is applied to both outputs.***

Another feature in PWM output mode is on Output 1, the setpoint **"PWM Outputs Linked"** can be set to *TRUE*. In this case, Output 2 automatically gets set as PWM output type, and it will be driven with the inverse duty cycled as that applied to Output 1. In this mode, the outputs are no longer independent, but rather become mirror images of one another, as shown in Figure 6.



WARNING: These outputs are not a true H-bridge drive, so there is no deadband between turning off one output, and engaging the next. Therefore, this mode must not be used in any application where the load will short if both outputs are on at the same time.

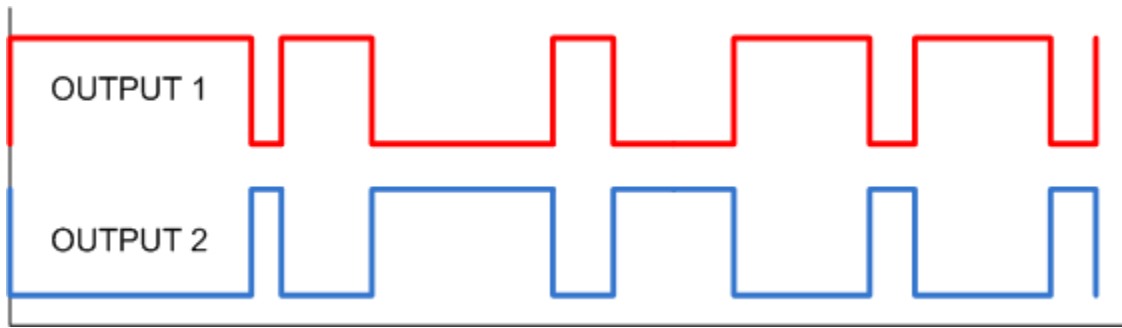

Figure 6 – PWM Outputs with Linked Response

Instead of proportional, there are also two types of digital responses possible as well. With the ‘*Digital On/Off*’ type, should the control require the output to be on, it will be turned on at whatever the system power supply is. The output will source whatever current is required by the load, up to 2.5A.

If a non-digital control is selected, the command state will be OFF at or below the minimum input, ON at or above the maximum input, and it will not change in between those points. In other words, the input will have built in hysteresis, as shown in Figure 7. This relationship is true for any function block that has a non-digital input mapped to a digital control.

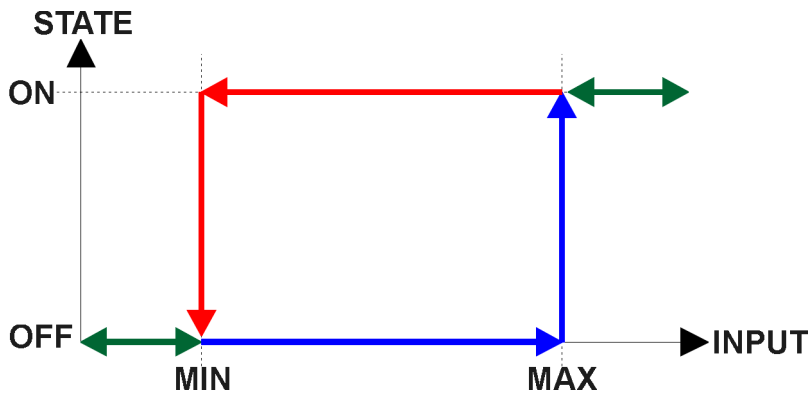

Figure 7 – Analog to Digital Input

If a digital “**Output Type**” has been selected the “**Digital Response**” setpoint will be enabled as shown in Table 4. Also, the “**Digital Override State**” setpoint will be enabled, and will follow the Override input the same way that the “**Output at Override Command**” would be used with a proportional output response.

0	<i>Normal On/Off</i>
1	<i>Inverse Logic</i>
2	<i>Latched Logic</i>
3	<i>Blinking Logic</i>

Table 4 – Digital Response Options

In a ‘*Normal*’ response, when the Control input commands the output ON, then the output will be turned ON. However, in an ‘*Inverse*’ response, the output will be ON unless the input commands the output ON, in which case it turns OFF.

If a *'Latched'* response is selected, when the input commands the state from OFF to ON, the output will change state.

If a *'Blinking'* response is selected, then while the input command the output ON, it will blink at the rate in the **"Digital Blink Rate"** setpoint. When commanded OFF, the output will stay off. A blinking response is only available with a *'Digital On/Off'* type of output (not a Hotshot type.)

The *'Hotshot Digital'* type is different from in simple *'Digital On/Off'* in that it still controls the current through the load. This type of output is used to turn on a coil then reduce the current so that the valve will remain open, as shown in Figure 8 below. Since less energy is used to keep the output engaged, this type of response is very useful to improve overall system efficiency.

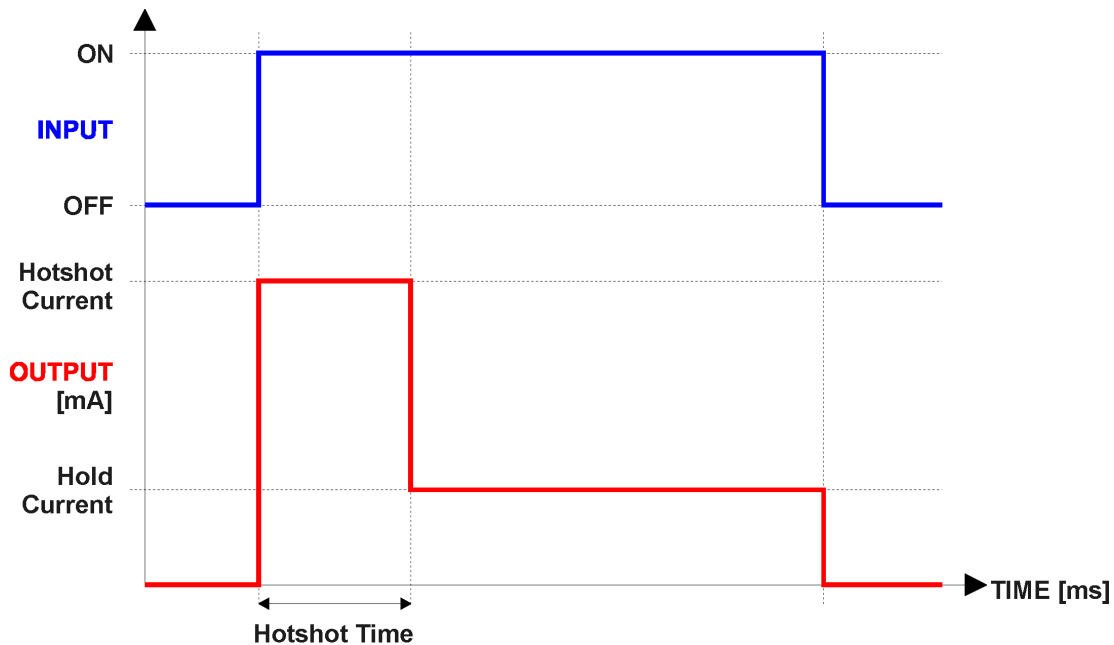

Figure 8 – Hotshot Digital Profile

Open or Short Circuits

The outputs are inherently protected against a short to GND or +Vcc by circuitry. In the case of a dead short, the hardware will automatically disable the output drive, regardless of what the processor is commanding for the output. The processor will be flagged by the hardware that the output circuitry has been shutoff due to a short at the output, but it will not know if it is because of a short to GND or +Vcc.

For this reason, both types of shorts would be identified on the CAN network with the same Failure Mode Indicator (FMI). For the default *'Proportional Current'* type of output, a short at the output would set an FMI of 6, **Current Above Normal or Grounded Circuit**.

Unless commanded OFF by some other logic, when a short disables the output, the processor will still attempt to drive the output to the desired value. When the short is removed, the output automatically recovers and resumes normal operation.

Similarly, in the case of an open circuit there will be no interruption of the control logic for either output. The processor will continue to attempt to drive the open load based on the logic shown in Figure 4.

While commanded ON, the processor will detect and flag an open circuit when the measured feedback current through the load is less than the expected output value by more than the value in the “**Hysteresis to Clear Fault**” setpoint for the associated output. In this case, for the default ‘*Proportional Current*’ type of output, an open at the output would set an FMI of 5, **Current Below Normal or Open Circuit**.

In order to prevent accidental setting/clearing of the open circuit error flag while the current is changing due to a newly commanded output, the target command value must remain constant for a period of time determined by the “**Output Target Command Stable Timer**.” There is only one timer which is shared by both outputs, so this setpoint can be found in the **Miscellaneous** group.

Only when the output target has remained constant for enough time for the feedback to have stabilized with the controller then compare the target and feedback values to check for an open circuit. This value should be set long enough to make sure the feedback will have stabilized properly after the largest step change expected under normal operating conditions.

This controller also has the ability to detect and flag an open circuit (only in ‘*Proportional Current*’ mode) even when the output is commanded OFF. If the target output is zero, the controller will execute an open circuit test sub-routine whereby it will activate the output at a low current “**Zero Output Open Circuit Test Current**” for a short period of time determined by “**Zero Output Open Circuit Test ON Time**.” At the end of the ON test period it will sample the feedback current, and if less than the “**Zero Output Open Circuit Current OK**” value, then the open circuit test counter will be incremented. The output will then be reset to zero for “**Zero Output Open Circuit Test OFF Time**” after which the cycle repeats. If the current is measured to be less than the OK value for more than “**Zero Output Open Circuit Test Counter**” times, then the open circuit flag is set.

As with the target stable timer, the open circuit test values are shared between both outputs, so the setpoints listed in the above paragraph are also found in the **Miscellaneous** group.

To disable the open circuit detection at zero feature simply set the “**Zero Output Open Circuit Test Current**” setpoint to 0mA.

Once an open circuit has been flagged, it will be cleared once either the test current at zero comes above the “Current OK” value or the measured feedback comes back within the expected range of the target command as determined by the Hysteresis value. Since the open circuit will not disable the output (unless commanded OFF by some other logic) when the connection is fixed, the output automatically recovers and resumes normal operation.

The measured current through the load is available to be broadcasted on a CAN message if desired. It is also used as the input to the diagnostic function block for each output, and an open or shorted output can be broadcasted in a DM1 message on the CAN network. See Section 1.7 for the complete description of the diagnostic functions available on this controller.

1.3. PID Control Function Block

The PID Control function block is an independent logic block, but it is normally intended to be associated with proportional output control blocks described earlier. When the “**Control Source**” for an output has been setup as a ‘*PID Function Block*’, the command from the selected PID block drives the physical output on the 2oPi.

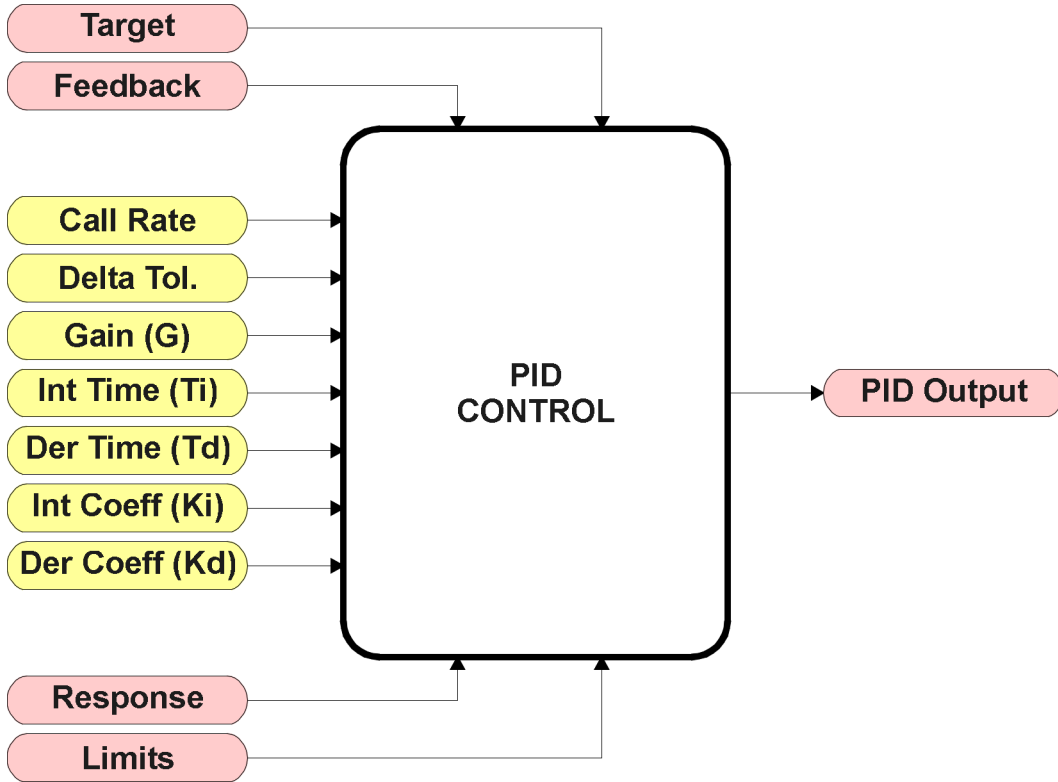

Figure 9 – PID Control Function Block

To use the PID calculations, the “**PID Target Command Source**” determines the control input, and the “**PID Feedback Input Source**” established the feedback signal to the PID function block. The “**PID Response Profile**” will use the selected inputs as per the options listed in Table 5. When active, the PID algorithm will be called every “**PID Loop Update Rate**” (in ms)

0	<i>Single Output</i>
1	<i>Setpoint Control</i>
2	<i>On When Over Target</i>
3	<i>On When Below Target</i>

Table 5 – PID Responses

When a ‘*Single Output*’ response is selected, the Target and Feedback inputs do not have to share the same units. In both cases, the signals are converted to a percentage value based on the minimum and maximum values associated with the source function block.

For example, a CAN command (i.e. 0 to 3000mA) could be used to set the target value, in which case it would be converted to a percentage value using the “**Received Data Min**” and “**Received Data Max**” setpoints in the appropriate ‘*CAN Receive X*’ function block. The close-loop feedback

signal (i.e. a 0-5V input) could be received on another CAN channel. In this case the value of the input would also be converted to a percentage based on the “**Received Data Min**” and “**Received Data Max**” setpoints in that block. The output of the PID function would depend on the difference between the commanded target and the measured feedback as a percentage of each signal’s range. In this mode, the output from the block would be a value in the range -100% to 100%.

When a ‘*Setpoint Control*’ response is selected, the “**PID Target Command Source**” automatically gets updated to ‘*Control Constant Data*’ and cannot be changed. The value set in the associated constant in the Constant Data List function block becomes the desired target value. In this case, both the target and feedback values are assumed to be in the same units and range. The minimum and maximum values for the feedback automatically become the constraints on the constant target. In this mode, the output of the block would be a value from 0% to 100%.

For example, if the feedback was setup as a 4-20mA input, a “Constant Value X” setpoint set to 14.2 would automatically be converted to 63.75%. The PID function would adjust the output as needed to have the measured feedback to maintain that target value.

The last two response options, ‘*On When Over Target*’ and ‘*On When Below Target*’, are designed to allow the user to combine the two proportional outputs as a push-pull drive for a system. Both outputs must be setup to use the same control input (linear response) and feedback signal in order to get the expected output response. In this mode, the output would also be between 0% to 100%.

In order to allow the output to stabilize, the user can select a non-zero value for “**PID Delta Tolerance**”. If the absolute value of $Error_k$ is less than this value, $Error_k$ in the formula below will be set to zero.

The PID algorithm used is shown below, with names in red being the configurable parameters.

$$\begin{aligned}
 T &= \text{Loop_Update_Rate} * 0.001 \\
 P_Gain &= G \\
 I_Gain &= G * K_i * T / T_i \\
 D_Gain &= G * K_d * T_d / T \\
 \text{Note: If } T_i \text{ is zero, } I_Gain &= 0 \\
 \\
 Error_k &= \text{Target} - \text{Feedback} \\
 ErrorSum_k &= ErrorSum_{k-1} + Error_k \\
 \\
 P_k &= Error_k * P_Gain \\
 \\
 I_k &= ErrorSum_k * I_Gain \\
 \\
 D_k &= (Error_k - Error_{k-1}) * D_Gain \\
 \\
 PIDOutput_k &= P_k + I_k + D_k
 \end{aligned}$$

Figure 10 – PID Control Algorithm

Each system will have to be tuned for the optimum output response. Response times, overshoots and other variables will have to be decided by the customer using an appropriate PID tuning strategy. Axiomatic is not responsible for tuning the control system.

1.4. Lookup Table Function Block

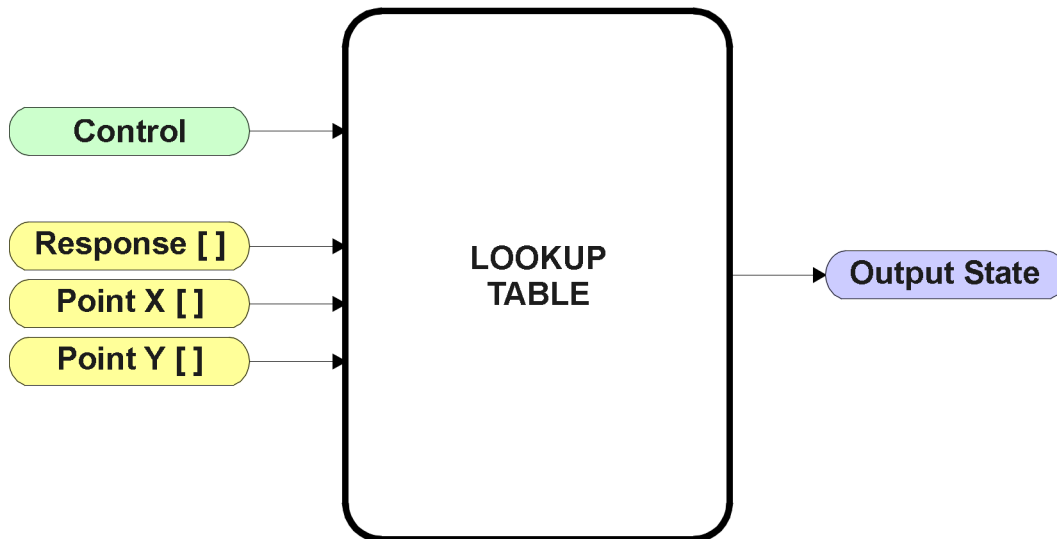

Figure 11 – Lookup Table Function Block

Lookup Tables are used to give an output response of up to 10 slopes per input. The array size of the Response [], Point X [] and Point Y [] setpoints shown in the block diagram above is therefore 11.

Note: If more than 10 slopes are required, a Programmable Logic Block can be used to combine up to three tables to get 30 slopes, as is described in Section 1.5.

There are two key setpoints that will affect this function block. The first is the “**X-Axis Source**” and “**X-Axis Number**” which together define the Control Source for the function block. When it is changed, the table is automatically updated with new defaults based on the X-Axis source selected if “**Auto update when control changes**” in the Miscellaneous block is *TRUE*.

As stated earlier if “**Auto update when control changes**” is *TRUE*, should the selected Control Source change (i.e. the Min or Max values of the function block are updated), the associated table will also be automatically updated with default settings, based on the new X-Axis limits.



Initialize the Control Source of a Lookup Table **BEFORE** changing the table values, as the new settings **WILL** get erased when the control is updated if the “**Auto update when control changes**” in the Miscellaneous function block is set to *TRUE*.

The second setpoint that will affect the function block (i.e. reset to defaults), is the “**X-Axis Type**”. By default, the tables have a ‘*Data Response*’ output. Alternatively, it can be selected as a ‘*Time Response*’, which is described later in Section 1.4.5.

1.4.1. X-Axis, Input Data Response

In the case where the **X-Axis Type** = *'Data Response'*, the points on the X-Axis represents the data of the control source.

For example, if the control source is a CAN Receive message, setup as a 0-5V type, with an operating range of 0.5V to 4.5V, the X-Axis will be setup to have a default **"Point 1 – X Value"** of 0.5V, and setpoint **"Point 10 – X Value"** will be set to 4.5V. The **"Point 0 – X Value"** will be set to the default value of 0.0V.

For most 'Data Responses', the default value at point (0,0) is [0,0].

However, should the minimum input be less than zero, for example a CAN message that is reflecting temperature in the range of -40°C to 210°C, then the **"Point 0 – X Value"** will be set to the minimum instead, in this case -40°C.

The constraint on the X-Axis data is that the next index value is greater than or equal to the one below it, as shown in the equation below. Therefore, when adjusting the X-Axis data, it is recommended that X₁₀ is changed first, then lower indexes in descending order.

$$\text{MinInputRange} \leq X_0 \leq X_1 \leq X_2 \leq X_3 \leq X_4 \leq X_5 \leq X_6 \leq X_7 \leq X_8 \leq X_9 \leq X_{10} \leq \text{MaxInputRange}$$

As stated earlier, MinInputRange and MaxInputRange will be determined by the X-Axis Source that has been selected.

If some of the data points are *'Ignored'* as described in Section 1.4.4, they will not be used in the X-Axis calculation shown above. For example, if points X₄ and higher are ignored, the formula becomes $\text{MinInputRange} \leq X_0 \leq X_1 \leq X_2 \leq X_3 \leq \text{MaxInputRange}$ instead.

1.4.2. Y-Axis, Lookup Table Output

The Y-Axis has no constraints on the data that it represents. This means that inverse, or increasing/decreasing or other responses can be easily established.

For example, should the X-Axis of a table be a resistive value (as read from another controller), the output of the table could be temperature from an NTC sensor in the range Y₀=125°C to Y₁₀= -20°C. If this table is used as the control source for another function block (i.e. transmitted over CAN), then Xmin would be -20 and Xmax would be 125 when used the linear formula.

In all cases, the controller looks at the **entire range** of the data in the Y-Axis setpoints, and selects the lowest value as the MinOutRange and the highest value as the MaxOutRange. They are passed directly to other function blocks as the limits on the Lookup Table output. (i.e used as Xmin and Xmax values in linear calculations.)

However, if some of the data points are *'Ignored'* as described in Section 1.4.4, they will not be used in the Y-Axis range determination. Only the Y-Axis values shown on the Axiomatic EA will be considered when establishing the limits of the table when it is used to drive another function block, such as an Output Drive.

1.4.3. Default Configuration, Data Response

By default, all Lookup Tables in the ECU are disabled (“X-Axis Source” equals ‘Control Source Not Used’.) If they were to use the default settings for Inputs 1 and 2 instead as the X-Axis, and output current (in mA) they could be used to control the corresponding Output Drives. If a non-linear response for one or more of the outputs is required, the user can easily use the table(s) to create the desired response profiles.

Recall, any controlled function block which uses the Lookup Table as an input source (not only the Output Drive) will also apply a linearization to the data. **Therefore, for a 1:1 control response, ensure that the minimum and maximum values of the output (Ymin and Ymax in Figure 3) correspond to the minimum and maximum values of the table’s Y-Axis (Xmin and Xmax in Figure 3).**

To control “Output N Drive” by “Received Message N” modified by “Lookup Table N” (N = 1 to 2) it is recommended to do so in the following order:

- a) Change Output Drive “**Output at Minimum Command**” and “**Output at Maximum Command**” to the desired limits.
- b) Set “**Auto update when control changes**” in the Miscellaneous block to *TRUE* (optional)
- c) Configure the desired Control Source (i.e. CAN Receive Message), and set the appropriate limits.
- d) Change the Lookup Table X “**X-Axis Source**” setpoints. (If applicable)
At this point, the X-Axis limits will match the control source, and the Y-Axis limits and the Y-Axis limits would correspond to the Output Drive range, as a percentage.
- e) Update the X and Y setpoints for the application

Note: Order (c) to (e) holds true for all configuration done using any Lookup Table function block.

All tables (1 to 8) are disabled by default (no control source selected). However, should an “**X-Axis Source**” be selected, the Y-Axis defaults will be in the range of 0 to 100% as described in the “Y-Axis, Lookup Table Output” section above. X-Axis minimum and maximum defaults will be set as described in the “X-Axis, Data Response” section above.

By default, the X and Y axes data is setup for an equal value between each point from the minimum to maximum in each case.

For example, with a 0.5 to 4.5V input (X-Axis) driving a 0 to 1500mA output (Y-Axis), the default points would be setup as per figure (a) below. However, a 100Ω to 54kΩ input (X-Axis) representing 120°C to -30°C (Y-Axis) would be setup as per figure (b) below. In each case, the user would have to adjust the table for the desired response.

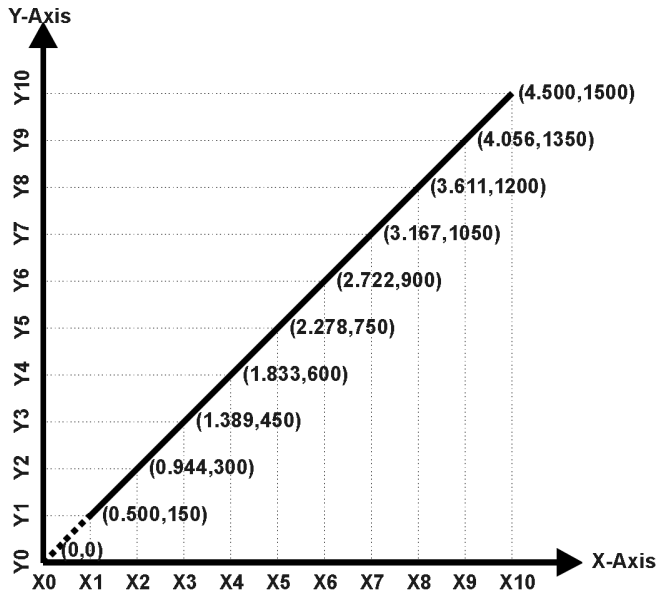

Figure A - 0.5 to 4.5V Input, 0 to 1500mA Output

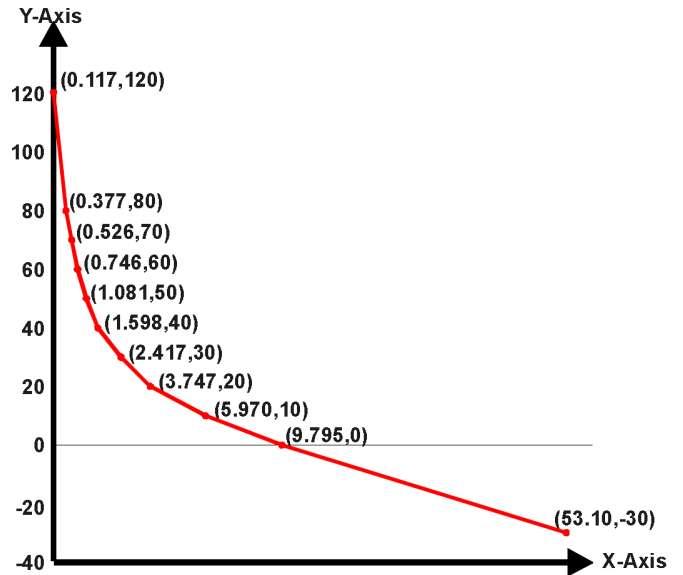

Figure B - 0.1 to 54kOhm Input, 120 to -30°C Output

Figure 12 – Lookup Table Initialization Examples

1.4.4. Point To Point Response

By default, the X and Y axes are setup for a linear response from point (0,0) to (10,10), where the output will use linearization between each point, as shown in Figure 12. To get the linearization, each **“Point N – Response”**, where N = 1 to 10, is setup for a *‘Ramp To’* output response.

Alternatively, the user could select a *‘Jump To’* response for **“Point N – Response”**, where N = 1 to 10. In this case, any input value between X_{N-1} to X_N will result in an output from the Lookup Table function block of Y_N.

An example of a CAN message (0 to 100) used to control a default table (0 to 100) but with a *‘Jump To’* response instead of the default *‘Ramp To’* is shown in Figure 13.

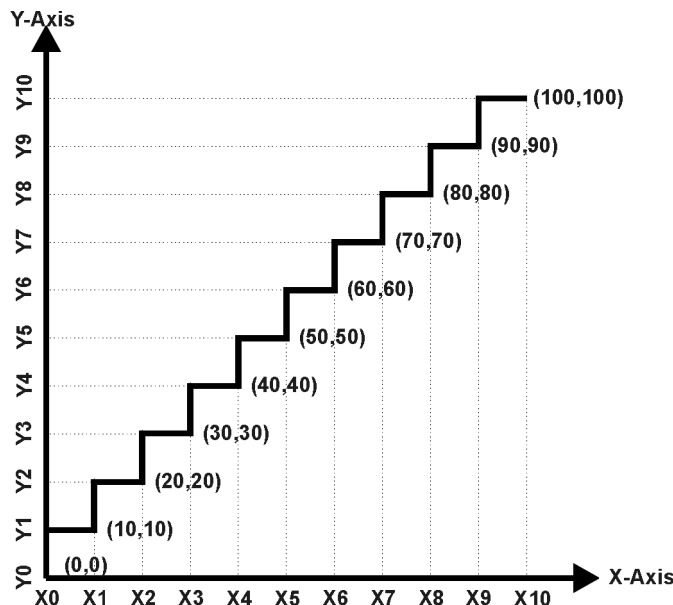

Figure 13 – Lookup Table “Jump To” Data Response

Lastly, any point except (0,0) can be selected for an 'Ignore' response. If "Point N – Response" is set to ignore, then all points from (X_N, Y_N) to (X₁₀, Y₁₀) will also be ignored. For all data greater than X_{N-1}, the output from the Lookup Table function block will be Y_{N-1}.

A combination of 'Ramp To', 'Jump To' and 'Ignore' responses can be used to create an application specific output profile. An example of where the same input (i.e. a CAN Message) is used as the X-Axis for two tables, but where the output profiles 'mirror' each other for a deadband joystick response is shown in Figure 14. The example shows a dual slope output response for each side of the deadband, but additional slopes can be easily added as needed.

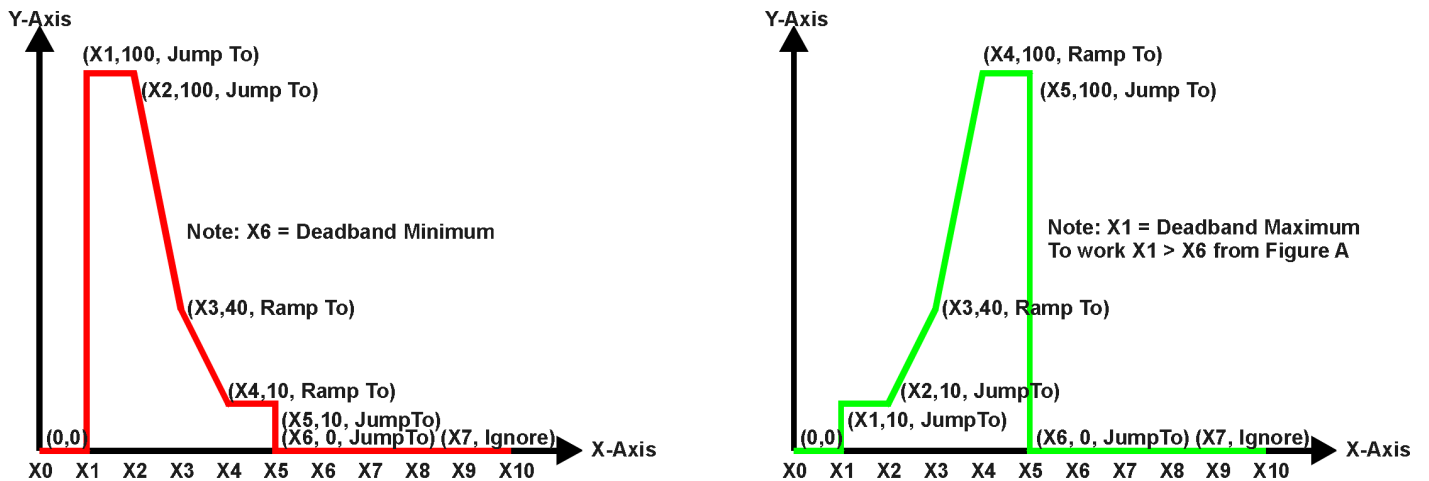

Figure A - Dual Slope "Profile B" Joystick Deadband Response

Figure B - Dual Slope "Profile A" Joystick Deadband Response

Figure 14 – Lookup Table Examples to Setup for Joystick Deadband Response

1.4.5. X-Axis, Time Response

As mentioned in Section 1.5, a Lookup Table can also be used to get a custom output response where the "X-Axis Type" is a 'Time Response.' When this is selected, the X-Axis now represents time, in units of milliseconds, while the Y-Axis still represents the output of the function block.

In this case, the "X-Axis Source" is treated as a digital input. If the signal is actually an analog input, it is interpreted like a digital input per Figure 7. When the control input is ON, the output will be changed over a period of time based on the profile in the Lookup Table. Once the profile has finished (i.e. index 10, or 'Ignored' response), the output will remain at the last output at the end of the profile until the control input turns OFF.

When the control input is OFF, the output is always at zero. When the input comes ON, the profile ALWAYS starts at position (X₀, Y₀) which is 0 output for 0ms.

When using the Lookup Table to drive an output based on time, it is mandatory that setpoints "Ramp Up (min to max)" and "Ramp Down (max to min)" in the Output X Drive function block be set to zero. Otherwise, the output result will not match the profile as expected. Recall, also, that the Y-Axis range of the table should be set to match the Output Drive range in order to get a 1:1 response of table output versus drive output.

An application where this feature would be useful is filling a clutch when a transmission is engaged. An example of some fill profiles is shown in Figure 15.

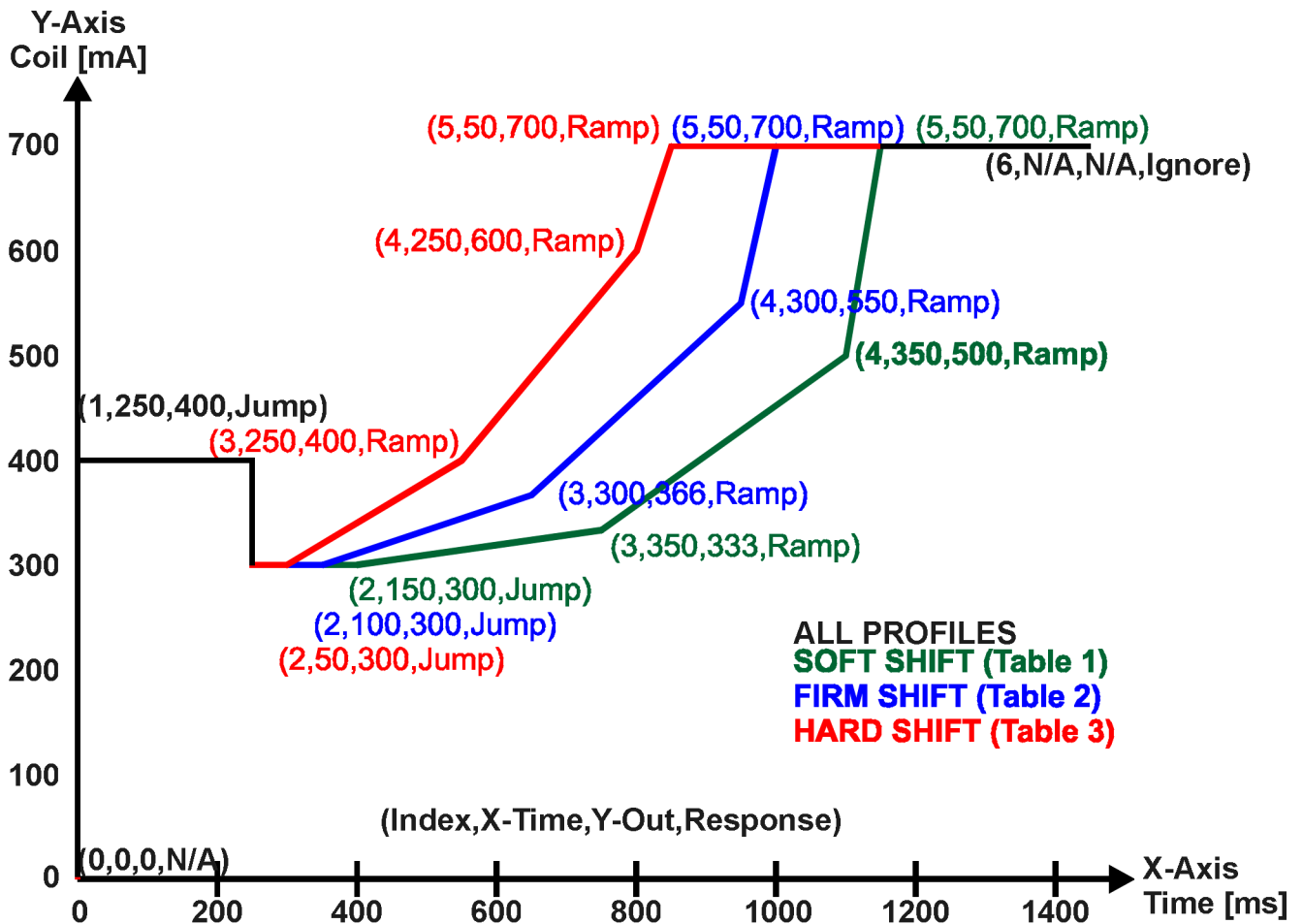

Figure 15 – Lookup Table Time Response Clutch Fill Profiles

In a time response, the interval time between each point on the X-axis can be set anywhere from 1ms to 24 hours. [86,400,000 ms]

One final note about the Lookup Tables is that if a digital input is selected as the control source for the X-Axis, only a 0 (Off) or 1 (On) will be measured. Ensure that the data range for the X-Axis on the table is updated appropriately in this condition.

Electronic Assistant

File View Options Help

CAN SP SP F

J1939 CAN Network

- ECU AX022002, CAN with Dual 3A Outputs,
 - General ECU Information
 - Setpoint File
 - Miscellaneous
 - Output 1 Drive
 - Output 2 Drive
 - Constant Data List
 - PID Control 1
 - PID Control 2
 - Lookup Table 1
 - Lookup Table 2
 - Lookup Table 3
 - Lookup Table 4
 - Lookup Table 5
 - Lookup Table 6
 - Lookup Table 7
 - Lookup Table 8
 - Programmable Logic 1
 - Programmable Logic 2
 - Programmable Logic 3
 - Programmable Logic 4
 - Math Function 1
 - Math Function 2
 - Math Function 3
 - Math Function 4
 - CAN Transmit 1
 - CAN Transmit 2
 - CAN Transmit 3
 - CAN Transmit 4
 - CAN Transmit 5
 - CAN Transmit 6
 - CAN Transmit 7
 - CAN Transmit 8
 - CAN Receive 1
 - CAN Receive 2
 - CAN Receive 3
 - CAN Receive 4
 - CAN Receive 5

Setpoint Name	Value	Comment
SP X-Axis Source	1	Received CAN J1939 Message
SP X-Axis Number	1	Received Message 1, Default Output 1 Command
SP X-Axis Type	1	Time Response
SP Point 1 - Response	2	Jump To
SP Point 2 - Response	2	Jump To
SP Point 3 - Response	1	Ramp To
SP Point 4 - Response	1	Ramp To
SP Point 5 - Response	1	Ramp To
SP Point 6 - Response	0	Ignore
SP Point 7 - Response		This point (and higher) is ignored
SP Point 8 - Response		This point (and higher) is ignored
SP Point 9 - Response		This point (and higher) is ignored
SP Point 10 - Response		This point (and higher) is ignored
SP Point 0 - X Value		Parameter not used with this configuration
SP Point 1 - X Value	250.000	ms
SP Point 2 - X Value	150.000	ms
SP Point 3 - X Value	350.000	ms
SP Point 4 - X Value	350.000	ms
SP Point 5 - X Value	50.000	ms
SP Point 6 - X Value		This point (and higher) is ignored
SP Point 7 - X Value		This point (and higher) is ignored
SP Point 8 - X Value		This point (and higher) is ignored
SP Point 9 - X Value		This point (and higher) is ignored
SP Point 10 - X Value		This point (and higher) is ignored
SP Point 0 - Y Value		Parameter not used with this configuration
SP Point 1 - Y Value	400.000	
SP Point 2 - Y Value	300.000	
SP Point 3 - Y Value	333.000	
SP Point 4 - Y Value	500.000	
SP Point 5 - Y Value	700.000	
SP Point 6 - Y Value		This point (and higher) is ignored
SP Point 7 - Y Value		This point (and higher) is ignored
SP Point 8 - Y Value		This point (and higher) is ignored
SP Point 9 - Y Value		This point (and higher) is ignored
SP Point 10 - Y Value		This point (and higher) is ignored

Ready

Figure 16 – Lookup Table “Soft Shift” Axiomatic EA Configuration

1.5. Programmable Logic Function Block

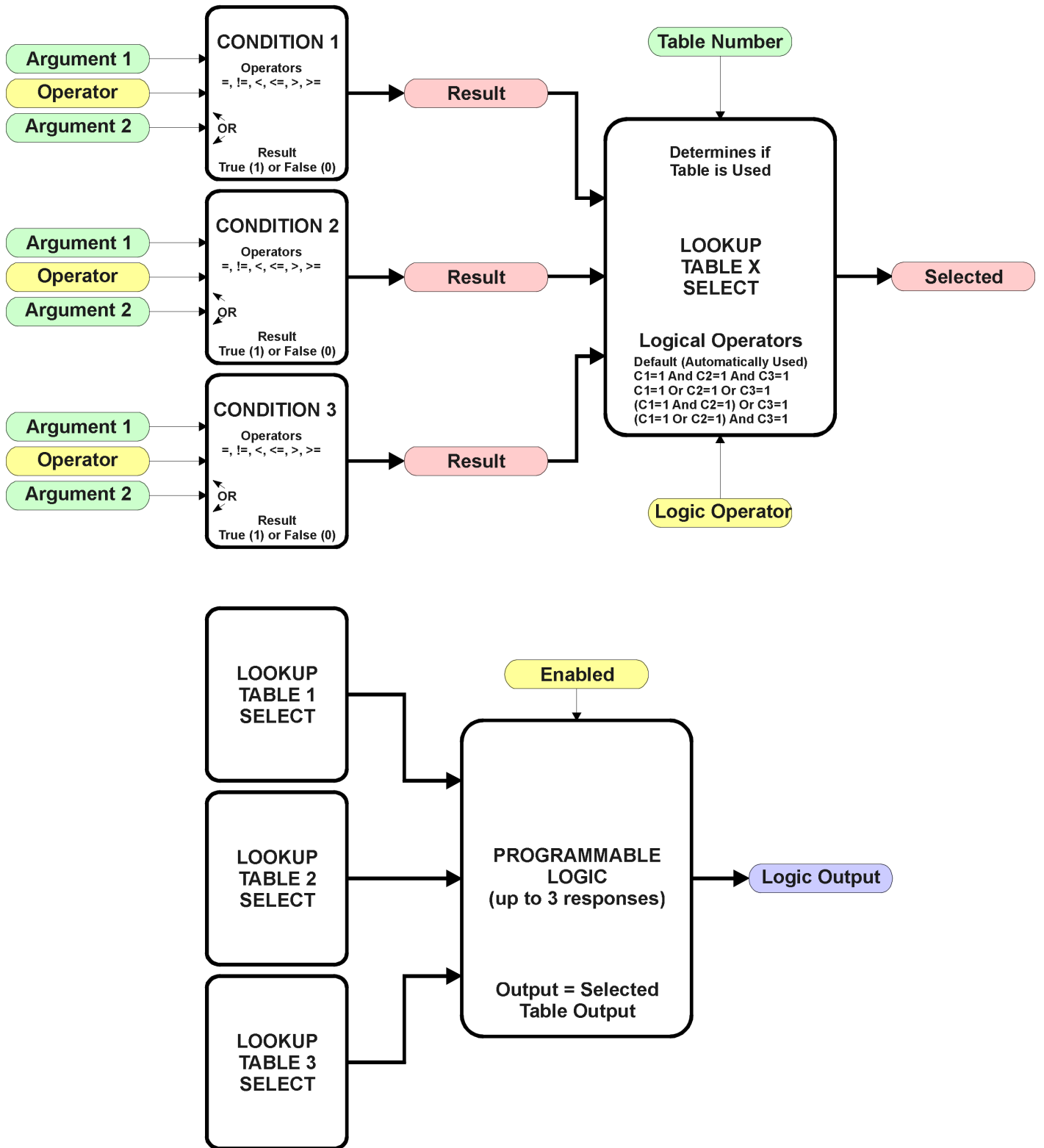

Figure 17 – Programmable Logic Function Block

This function block is obviously the most complicated of them all, but very powerful. The Programmable Logic can be linked to up to three tables, any one of which would be selected only under given conditions. Any three tables (of the available 8) can be associated with the logic, and which ones are used is fully configurable.

Should the conditions be such that a particular table (1, 2 or 3) has been selected as described in Section 1.5.2, then the output from the selected table, at any given time, will be passed directly to the Logic Output.

Therefore, up to three different responses to the same input, or three different responses to different inputs, can become the input to another function block, such as an Output X Drive. To do this, the “**Control Source**” for the reactive block would be selected to be the ‘*Programmable Logic Function Block*.’

In order to enable any one of Programmable Logic blocks, the “**Programmable Logic Block Enabled**” setpoint must be set to True. They are all disabled by default.

Logic is evaluated in the order shown in Figure 18. Only if a lower number table has not been selected will the conditions for the next table be looked at. **The default table is always selected as soon as it is evaluated. It is therefore required that the default table always be the highest number in any configuration.**

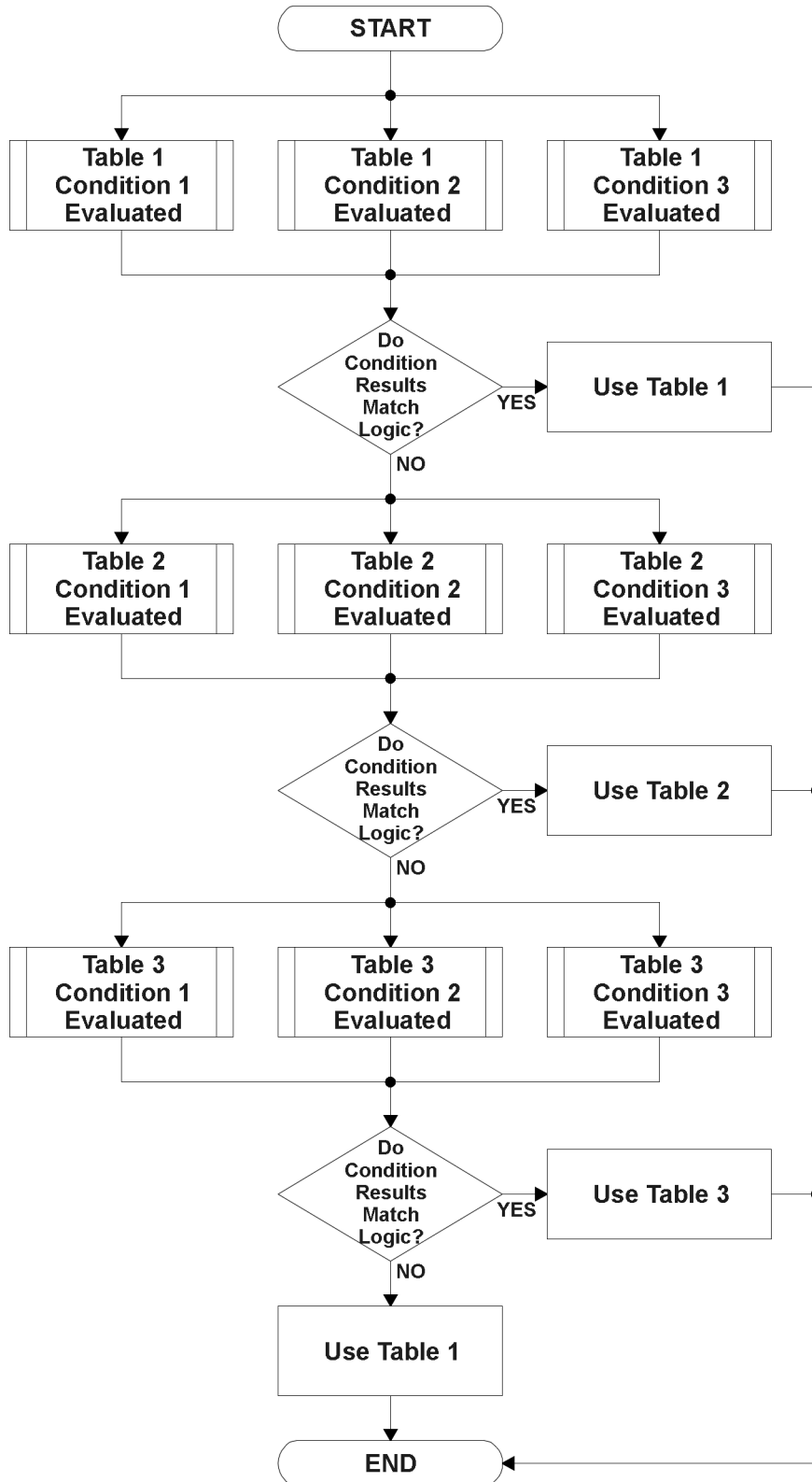

Figure 18 – Programmable Logic Flowchart

1.5.1. Conditions Evaluation

The first step in determining which table will be selected as the active table is to first evaluate the conditions associated with a given table. Each table has associated with it up to three conditions that can be evaluated.

Argument 1 is always a logical output from another function block, as listed in Section 1.11. As always, the source is a combination of the functional block type and number, setpoints “**Table X, Condition Y, Argument 1 Source**” and “**Table X, Condition Y, Argument 1 Number**”, where both X = 1 to 3 and Y = 1 to 3.

Argument 2 on the other hand, could either be another logical output such as with Argument 1, OR a constant value set by the user. To use a constant as the second argument in the operation, set “**Table X, Condition Y, Argument 2 Source**” to ‘*Control Constant Data.*’ Note that the constant value has no unit associated with it in the Axiomatic EA, so the user must set it as needed for the application.

The condition is evaluated based on the “**Table X, Condition Y Operator**” selected by the user. It is always ‘=, Equal’ by default. The only way to change this is to have two valid arguments selected for any given condition. Options for the operator are listed in Table 6.

0	=, <i>Equal</i>
1	!=, <i>Not Equal</i>
2	>, <i>Greater Than</i>
3	>=, <i>Greater Than or Equal</i>
4	<, <i>Less Than</i>
5	<=, <i>Less Than or Equal</i>

Table 6 – Condition Operator Options

For example, a condition for a transmission control shift selection, as shown in Figure 15 in the previous section, could be that the Engine RPM received on CAN message 3 be less than a certain value to select a Soft Fill profile. In this case, “**...Argument 1 Source**” would be set to ‘*Received CAN J1939 Message 3*’, “**...Argument 2 Source**” to ‘*Control Constant Data*’, and the “**...Operator**” to ‘<, *Less Than.*’ The “**Constant Value X**” in the Constant Data List would be set to whatever cutoff RPM the application required.

By default, both arguments are set to ‘*Control Source Not Used*’ which disables the condition, and automatically results in a value of N/A as the result. Although Figure 18 shows only True or False as a result of a condition evaluation, the reality is that there could be four possible results, as described in Table 7.

Value	Meaning	Reason
0	False	(Argument 1) Operator (Argument 2) = False
1	True	(Argument 1) Operator (Argument 2) = True
2	Error	Argument 1 or 2 output was reported as being in an error state
3	Not Applicable	Argument 1 or 2 is not available (i.e. set to ‘ <i>Control Source Not Used</i> ’)

Table 7 – Condition Evaluation Results

1.5.2. Table Selection

In order to determine if a particular table will be selected, logical operations are performed on the results of the conditions as determined by the logic in Section 1.5.1. There are several logical combinations that can be selected, as listed in Table 8.

0	<i>Default Table</i>
1	<i>Cnd1 And Cnd2 And Cnd3</i>
2	<i>Cnd1 Or Cnd2 Or Cnd3</i>
3	<i>(Cnd1 And Cnd2) Or Cnd3</i>
4	<i>(Cnd1 Or Cnd2) And Cnd3</i>

Table 8 – Conditions Logical Operator Options

Not every evaluation is going to need all three conditions. The case given in the earlier section, for example, only has one condition listed, i.e. that the Engine RPM be below a certain value. Therefore, it is important to understand how the logical operators would evaluate an Error or N/A result for a condition.

Logical Operator	Select Conditions Criteria
Default Table	Associated table is automatically selected as soon as it is evaluated.
Cnd1 And Cnd2 And Cnd3	<p>Should be used when two or three conditions are relevant, and all must be true to select the table.</p> <p>If any condition equals False or Error, the table is not selected. An N/A is treated like a True. If all three conditions are True (or N/A), the table is selected.</p> <p>If((Cnd1==True) &&(Cnd2==True)&&(Cnd3==True)) Then Use Table</p>
Cnd1 Or Cnd2 Or Cnd3	<p>Should be used when only one condition is relevant. Can also be used with two or three relevant conditions.</p> <p>If any condition is evaluated as True, the table is selected. Error or N/A results are treated as False</p> <p>If((Cnd1==True) (Cnd2==True) (Cnd3==True)) Then Use Table</p>
(Cnd1 And Cnd2) Or Cnd3	<p>To be used only when all three conditions are relevant.</p> <p>If both Condition 1 and Condition 2 are True, OR Condition 3 is True, the table is selected. Error or N/A results are treated as False</p> <p>If(((Cnd1==True)&&(Cnd2==True)) (Cnd3==True)) Then Use Table</p>
(Cnd1 Or Cnd2) And Cnd3	<p>To be used only when all three conditions are relevant.</p> <p>If Condition 1 And Condition 3 are True, OR Condition 2 And Condition 3 are True, the table is selected. Error or N/A results are treated as False</p> <p>If(((Cnd1==True) ((Cnd2==True)) && (Cnd3==True)) Then Use Table</p>

Table 9 – Conditions Evaluation Based on Selected Logical Operator

The default “**Table X, Conditions Logical Operator**” for Table 1 and Table 2 is ‘*Cnd1 And Cnd2 And Cnd3*,’ while Table 3 is set to be the ‘*Default Table*.’

1.5.3. Logic Block Output

Recall that Table X, where X = 1 to 3 in the Programmable Logic function block does NOT mean Lookup Table 1 to 3. Each table has a setpoint “**Table X – Lookup Table Block Number**” which allows the user to select which Lookup Tables they want associated with a particular Programmable Logic Block. The default tables associated with each logic block are listed in Table 10.

Programmable Logic Block Number	Table 1 – Lookup Table Block Number	Table 2 – Lookup Table Block Number	Table 3 – Lookup Table Block Number
1	1	2	3
2	4	5	6
3	1	2	3
4	4	5	6

Table 10 – Programmable Logic Block Default Lookup Tables

If the associated Lookup Table does not have an “**X-Axis Source**” selected, then the output of the Programmable Logic block will always be “Not Available” so long as that table is selected. However, should the Lookup Table be configured for a valid response to an input, be it Data or Time, the output of the Lookup Table function block (i.e. the Y-Axis data that has been selected based on the X-Axis value) will become the output of the Programmable Logic function block so long as that table is selected.

Unlike all other function blocks, the Programmable Logic does NOT perform any linearization calculations between the input and the output data. Instead, it mirrors exactly the input (Lookup Table) data. Therefore, when using the Programmable Logic as a control source for another function block, it is HIGHLY recommended that all the associated Lookup Table Y-Axes either be (a) Set between the 0 to 100% output range or (b) all set to the same scale.

1.5.4. Application Ideas

This section is not meant to be a comprehensive list of all the possibilities that the Programmable Logic offers. Rather, it is meant to show how some common, but widely diversified functions can be achieved by using it.

- a) Dual Speed Application – Under certain conditions, a valve could be driven between Min_A to Max_A while under others, the speed is limited by having the output respond to changes at the input between Min_B and Max_B.
- b) Multi-Speed Transmission Control – By using a Forward input as the enable of one Output X Drive, and the Reverse input as the other, different clutch fill profiles could be selected based on Engine Speed as discussed in earlier examples.
- c) Getting better resolution (i.e. up to 30 slopes) on a resistive to temperature curve for an NTC sensor. The condition for Table 1 would be input resistance $\leq R1$, Table 2 is input $\leq R2$ and Table 3 as the default for high resistance values.

1.6. Math Function Block

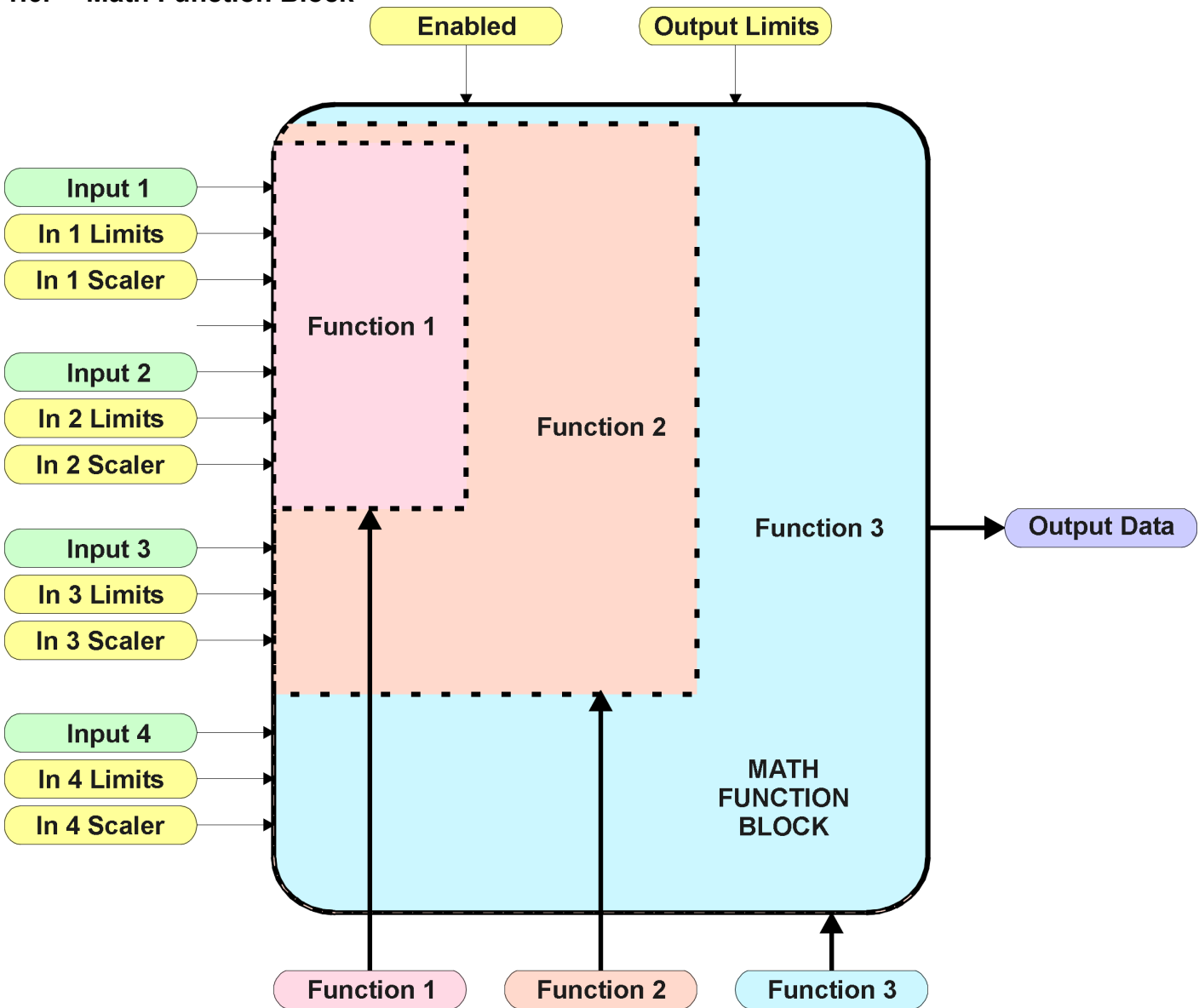

Figure 19 – Math Function Block

There are four mathematic function blocks that allow the user to define basic algorithms. A math function block can take up to four input signals, as listed in Table 16 in Section 1.11. Each input is then scaled according to the associated limit and scaling setpoints.

Inputs are converted into a percentage value based on the “**Math Input X Minimum**” and “**Math Input X Maximum**” values selected, where X = 1 to 4. For additional control, the user can also adjust the “**Math Input X Scaler.**” By default, each input has a scaling ‘weight’ of 1.0. However, each input can be scaled from -1.0 to 1.0 as necessary before it is applied in the function.

For example, in the case where the user may want to combine two inputs such that a joystick (Input 1) is the primary control of an output, but the speed can be incremented or decremented based on a potentiometer (Input 2), it may be desired that 75% of the scale is controlled by the joystick position, while the potentiometer can increase or decrease the min/max output by up to 25%. In this case, Input 1 would be scaled with 0.75, while Input 2 uses 0.25. The resulting addition will give a command from 0 to 100% based on the combined positions of both inputs.

The appropriate arithmetic or logical operation is performed on the two inputs, InA and InB, according to the associated function. The list of selectable function operations is defined in Table 11.

0	=	True when InA Equals InB
1	!=	True when InA Not Equal InB
2	>	True when InA Greater Than InB
3	>=	True when InA Greater Than or Equal InB
4	<	True when InA Less Than InB
5	<=	True when InA Less Than or Equal InB
6	OR	True when InA or InB is True
7	AND	True when InA and InB are True
8	XOR	True when InA/InB is True, but not both
9	+	Result = InA plus InB
10	-	Result = InA minus InB
11	x	Result = InA times InB
12	/	Result = InA divided by InB
13	MIN	Result = Smallest of InA and InB
14	MAX	Result = Largest of InA and InB

Table 11 – Math Function Operators

For Function 1, InA and InB are Inputs 1 and 2 respectively.

For Function 2, InA is the result of Function 1, and InB is Input 3.

For Function 3, InA is the result of Function 2, and InB is Input 4.

For a valid result, the control source for an input must be a non-zero value, i.e. something other than ‘Control Source Not Used.’ Otherwise, the corresponding function is ignored, and the “Output Data” for the math function block is the result of the earlier function scaled according to the output limit setpoints. For example, if Input 4 is not used, the math output would be the result of the Function 2 operation.

For logical operators (6, 7 or 8), any SCALED input greater than or equal to 0.5 is treated as a TRUE input. For logic output operators (0 to 8), the result of the calculation for the function will always be 0 (FALSE) or 1 (TRUE).

Error data (i.e. input measured out of range) is always treated as a 0.0 input into the function.

For the arithmetic functions (9 to 14), it is recommended to scale the data such that the resulting operation will not exceed full scale (0 to 100%) and saturate the output result.

When dividing, a zero InB value will always result in a zero output value for the associated function. When subtracting, a negative result will always be treated as a zero, unless the function is multiplied by a negative one, or the inputs are scaled with a negative coefficient first.

The resulting mathematical calculation, represented as a percentage value, can be scaled into the appropriate physical units using the “**Math Output Minimum Range**” and “**Math Output Maximum Range**” setpoints. These values are also used as the limits when the Math Function is selected as the input source for another function block.

1.7. Diagnostic Function Block

There are several types of diagnostics supported by the 2oPi. As described in Section 1.2, fault detection and reaction is associated with both output drives. In addition the 2oPi can also detect/react to power supply over/under voltage measurements, a processor over-temperature, or lost communication events.

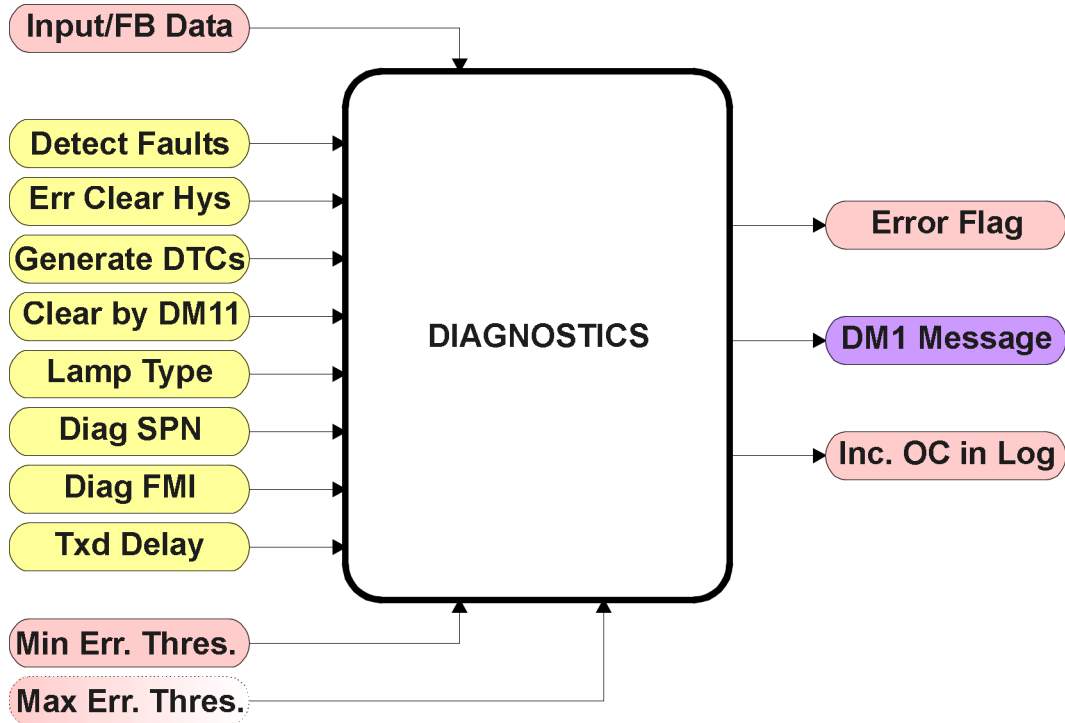

Figure 20 – Diagnostics Function Block

The “**Fault Detection is Enabled**” is the most important setpoint associated with this function block, and it should be selected first. Changing it will result in other setpoints being enabled/disabled as appropriate. When disabled, all diagnostic behaviour associated with the output or event in question is ignored (i.e. this type of fault will not disable the output.)

In the case of a power supply error, it can be selected to disable the 2.5A proportional outputs. By default, a power supply under or over voltage condition will not shutoff the outputs.

In most cases, faults can be flagged as either a low or high occurrence. The min/max thresholds for all diagnostics supported by the 2oPi are listed in Table 20. Bolded values are user configurable setpoints. Some diagnostics react only to a single condition, in which case a N/A is listed in one of the columns.

Function Block	Minimum Threshold	Maximum Threshold
Universal Input	Minimum Error	Maximum Error
Output Drive	Hysteresis to Clear Fault *	~4.5A * (Hardware)
Power Supply	Power Undervoltage Threshold	Power Overvoltage Threshold
Over Temperature	N/A	Over Temperature Shutdown
Lost Communication	N/A	Received Message Timeout (any)

Table 12 – Fault Detect Thresholds

The output current diagnostics will compare the desired current with the measured value, and if the difference between the two readings is greater the “Hysteresis to Clear Fault**” setpoint, an open circuit will be flagged. A hardware shutdown will occur if the output is sourcing greater than 4.5A +/- 0.5A, most likely due to a short circuit on the load. Output diagnostics are not available with non-current output types. See Section 1.2 for more information about Open/Short circuit detection.*

When applicable, a hysteresis setpoint is provided to prevent the rapid setting and clearing of the error flag when an input or feedback value is right near the fault detection threshold. For the low end, once a fault has been flagged, it will not be cleared until the measured value is greater than or equal to the Minimum Threshold + “**Hysteresis to Clear Fault.**” For the high end, it will not be cleared until the measured value is less than or equal to the Maximum Threshold – “**Hysteresis to Clear Fault.**” The minimum, maximum and hysteresis values are always measured in the units of the fault in question.

The next setpoint in this function block is the “**Event Generates a DTC in DM1.**” If and only if this is set to true will the other setpoints in the function block be enabled. They are all related to the data that is sent to the J1939 network as part of the DM1 message, Active Diagnostic Trouble Codes.

A Diagnostic Trouble Code (DTC) is defined by the J1939 standard as a four byte value which is a combination of:

SPN	Suspect Parameter Number	(first 19 bits of the DTC, LSB first)
FMI	Failure Mode Identifier	(next 5 bits of the DTC)
CM	Conversion Method	(1 bit, always set to 0)
OC	Occurrence Count	(7 bits, number of times the fault has happened)

In addition to supporting the DM1 message, the 2oPi also supports

DM2	Previously Active Diagnostic Trouble Codes	Sent only on request
DM3	Diagnostic Data Clear/Reset of Previously Active DTCs	Done only on request
DM11	Diagnostic Data Clear/Reset for Active DTCs	Done only on request

So long as even one Diagnostic function block has “**Event Generates a DTC in DM1**” set to True, the 2oPi will send the DM1 message every one second, regardless of whether or not there are any active faults, as recommended by the standard. While there are no active DTCs, the 2oPi will send the “No Active Faults” message. If a previously inactive DTC becomes active, a DM1 will be sent immediately to reflect this. As soon as the last active DTC goes inactive, it will send a DM1 indicating that there are no more active DTCs.

If there is more than one active DTC at any given time, the regular DM1 message will be sent using a multipacket Broadcast Announce Message (BAM). If the controller receives a request for a DM1 while this is true, it will send the multipacket message to the Requester Address using the Transport Protocol (TP).



At power up, the DM1 message will not be broadcasted until after a 5 second delay. This is done to prevent any power up or initialization conditions from being flagged as an active error on the network.

When the fault is linked to a DTC, a non-volatile log of the occurrence count (OC) is kept. As soon as the controller detects a new (previously inactive) fault, it will start decrementing the “**Delay Before Sending DM1**” timer for that Diagnostic function block. If the fault has remained present during the delay time, then the controller will set the DTC to active, and will increment the OC in the log. A DM1 will immediately be generated that includes the new DTC. The timer is provided so that intermittent faults do not overwhelm the network as the fault comes and goes, since a DM1 message would be sent every time the fault shows up or goes away.

Previously active DTCs (any with a non-zero OC) are available upon request for a **DM2** message. If there is more than one previously active DTC, the multipacket DM2 will be sent to the Requester Address using the Transport Protocol (TP).

Should a **DM3** be requested, the occurrence count of all previously active DTCs will be reset to zero. The OC of currently active DTCs will not be changed.

The Diagnostic function block has a setpoint “**Event Cleared only by DM11.**” By default, this is always set to False, which means that as soon as the condition that caused an error flag to be set goes away, the DTC is automatically made Previously Active, and is no longer included in the DM1 message. However, when this setpoint is set to True, even if the flag is cleared, the DTC will not be made inactive, so it will continue to be sent on the DM1 message. Only when a DM11 has been requested will the DTC go inactive. This feature may be useful in a system where a critical fault needs to be clearly identified as having happened, even if the conditions that caused it went away.

In addition to all the active DTCs, another part of the DM1 message is the first byte which reflects the Lamp Status. Each Diagnostic function block has the setpoint “**Lamp Set by Event in DM1**” which determines which lamp will be set in this byte while the DTC is active. The J1939 standard defines the lamps as ‘*Malfunction*’, ‘*Red, Stop*’, ‘*Amber, Warning*’ or ‘*Protect*’. By default, the ‘*Amber, Warning*’ lamp is typically the one set by any active fault.

By default, every Diagnostic function block has associated with it a proprietary SPN. However, this setpoint “**SPN for Event used in DTC**” is fully configurable by the user should they wish it to reflect a standard SPN define in J1939-71 instead. If the SPN is changed, the OC of the associate error log is automatically reset to zero.

Every Diagnostic function block also has associated with it a default FMI. The only setpoint for the user to change the FMI is “**FMI for Event used in DTC,**” even though some Diagnostic function blocks can have both high and low errors as shown in Table 13. In those cases, the FMI in the setpoint reflect that of the low end condition, and the FMI used by the high fault will be determined per Table 13. If the FMI is changed, the OC of the associate error log is automatically reset to zero.

FMI for Event used in DTC – Low Fault	Corresponding FMI used in DTC – High Fault
FMI=1, Data Valid But Below Normal Operational Range – Most Severe Level	FMI=0, Data Valid But Above Normal Operational Range – Most Severe Level
FMI=4, Voltage Below Normal, Or Shorted To Low Source	FMI=3, Voltage Above Normal, Or Shorted To High Source
FMI=5, Current Below Normal Or Open Circuit	FMI=6, Current Above Normal Or Grounded Circuit
FMI=17, Data Valid But Below Normal Operating Range – Least Severe Level	FMI=15, Data Valid But Above Normal Operating Range – Least Severe Level
FMI=18, Data Valid But Below Normal Operating Range – Moderately Severe Level	FMI=16, Data Valid But Above Normal Operating Range – Moderately Severe Level
FMI=21, Data Drifted Low	FMI=20, Data Drifted High

Table 13 – Low Fault FMI versus High Fault FMI



If the FMI used is anything other than one of those in Table 13, then both the low and high faults will be assigned the same FMI. This condition should be avoided, as the log will still used different OC for the two types of faults, even though they will be reported the same in the DTC. It is the user’s responsibility to make sure this does not happen.

1.8. DTC React Function Block

The DTC React function block is a very simple function which will allow a received DTC, sent from another ECU on a DM1 message, to disable an output or be used as input to another type of logic block. Up to five SPN/FMI combinations can be selected.

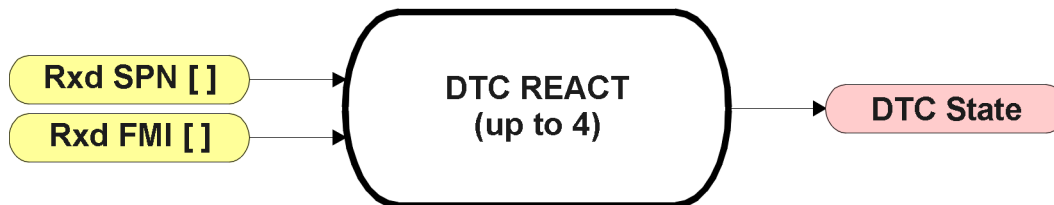

Figure 21 – DTC React Function Block

Should a DM1 message be received with the SPN/FMI combination defined, the corresponding DTC State will be set to ON. Once ON, if the same SPN/FMI combination has not been received again after 3 seconds, the DTC State will be reset to OFF.

The DTC could be used as a digital input for any function block as appropriate.

1.9. CAN Transmit Function Block

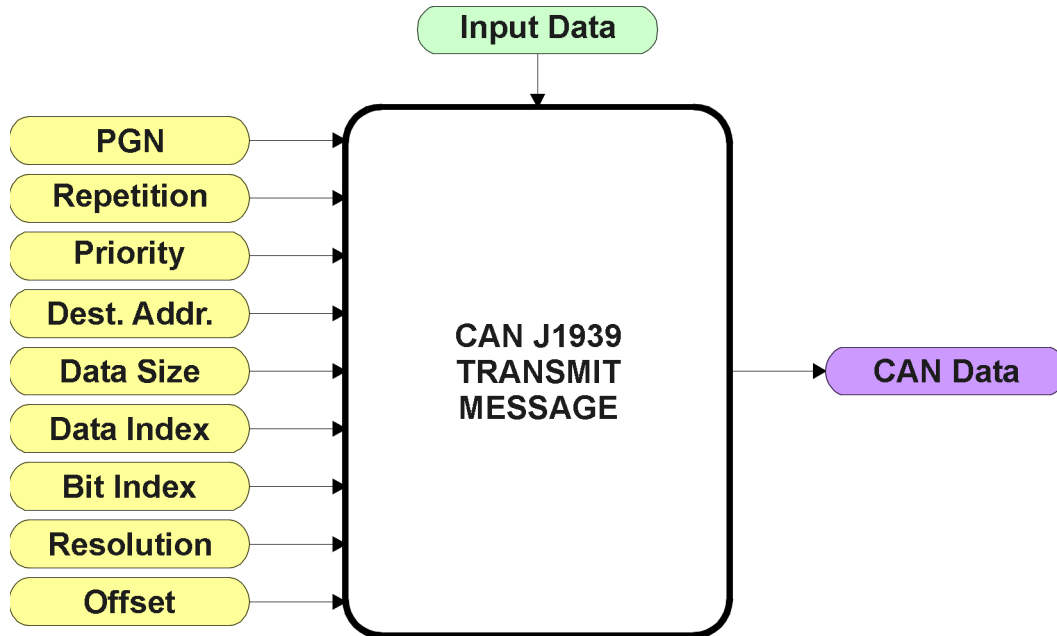

Figure 22 – CAN Transmit Function Block

The CAN Transmit function block is used to send any output from another function block (i.e. input, status or feedback signals) to the J1939 network.

Normally, to disable a transmit message, the “**Transmit Repetition Rate**” is set to zero. However, should message share its Parameter Group Number (PGN) with another message, this is not necessarily true. In the case where multiple messages share the same “**Transmit PGN**”, the repetition rate selected in the message with the **LOWEST** number will be used for **ALL** the messages that use that PGN.

By default, all messages are sent on Proprietary B PGNs as broadcast messages. The default settings do ‘bundle’ multiple messages onto a PGN, as outlined in Section 3. If all of the data is not necessary, disable the entire message by setting the lowest channel using that PGN to zero. If some of the data is not necessary, simply change the PGN of the superfluous channel(s) to an unused value in the Proprietary B range.



At power up, transmitted message will not be broadcasted until after a 5 second delay. This is done to prevent any power up or initialization conditions from creating problems on the network.

Since the defaults are PropB messages, the “**Transmit Message Priority**” is always initialized to 6 (low priority) and the “**Destination Address (for PDU1)**” setpoint is not used. This setpoint is only valid when a PDU1 PGN has been select, and it can be set either to the Global Address (0xFF) for broadcasts, or sent to a specific address as setup by the user.

The “**Transmit Data Size**”, “**Transmit Data Index in Array (LSB)**”, “**Transmit Bit Index in Byte (LSB)**”, “**Transmit Resolution**” and “**Transmit Offset**” can all be use to map the data to any SPN supported by the J1939 standard. The defaults used by the 2oPi are all for proprietary SPNs, and are defined in detail in Section 3.3.

Note: CAN Data = (Input Data – Offset)/Resolution

The 2oPi supports up to 8 unique CAN Transmit Messages, all of which can be programmed to send any available data to the CAN network. By default, only the first two messages are pre-configured to send the output feedback data. The details are outlined in Section 3.3, and the default list is shown in Table 14 below.

Block #	Default Transmit Data	(PGN)
1	Proportional Output 1 Current Feedback	(0xFF00)
2	Proportional Output 2 Current Feedback	(0xFF00)
3	Control Source Not Used	(0xFFFF)
4	Control Source Not Used	(0xFFFF)
5	Control Source Not Used	(0xFFFF)
6	Control Source Not Used	(0xFFFF)
7	Control Source Not Used	(0xFFFF)
8	Control Source Not Used	(0xFFFF)

Table 14 – Default CAN Transmit Messages

1.10. CAN Receive Function Block

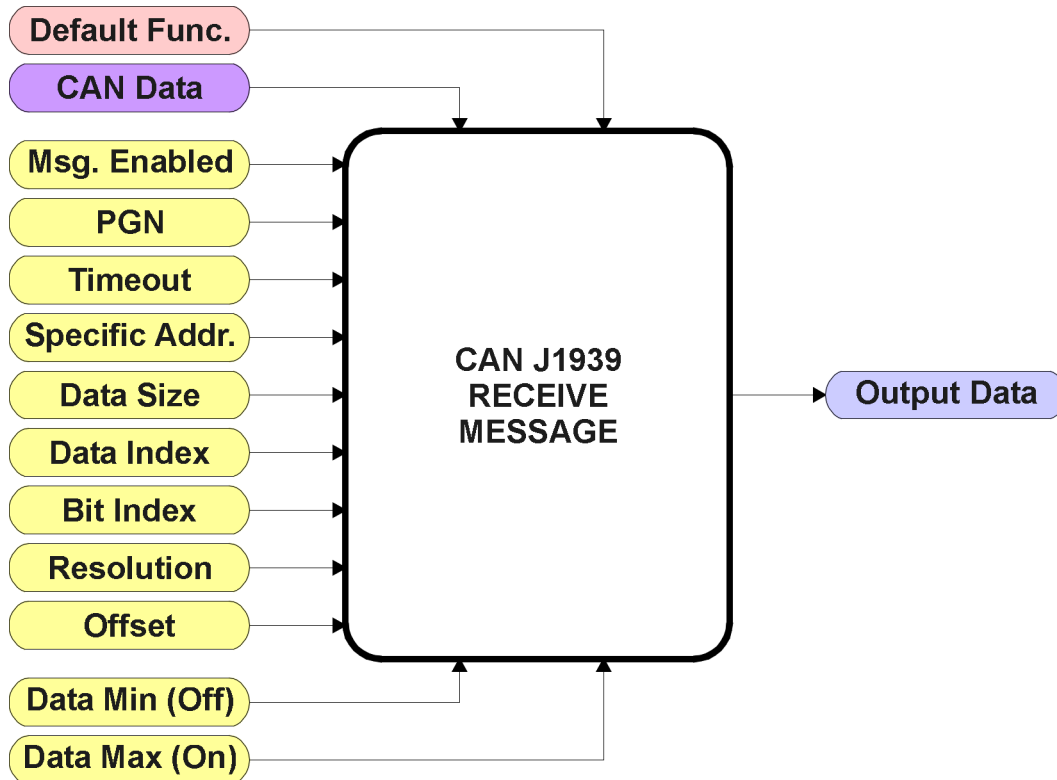



Figure 23 – CAN Receive Function Block

The CAN Receive function block is designed to take any SPN from the J1939 network, and use it as an input to any another function block (i.e. Lookup Table or Output Control).

The “**Received Message Enabled**” is the most important setpoint associated with this function block, and it should be selected first. Changing it will result in other setpoints being enabled/disabled as appropriate. By default ALL received messages are disabled.



Since the 2oPi can support up to 8 received messages, it can get confusing as to what message performs what function. Therefore, the intended “**Default Receive Function**” is available as a read-only value for each message. Change functions with CAUTION!

Once a message has been enabled, a Lost Communication fault will be flagged if that message is not received off of the bus within the “**Receive Message Timeout**” period. This could trigger a Lost Communication event as described in Section 1.7. In order to avoid timeouts on a heavily saturated network, it is recommended to set it at least three times larger than the expected update rate. To disable the timeout feature, simply set this value to zero, in which case the received message will never trigger a Lost Communication fault.

By default, all control messages are expected to be sent to the 2oPi on Proprietary B PGNs. However, should a PDU1 message be selected, the 2oPi can be setup to receive it from any ECU by setting the “**Specific Address that sends the PGN**” to the Global Address (0xFF). If a specific address is selected instead, then any other ECU sending data on the PGN will be ignored.

The “**Receive Data Size**”, “**Receive Data Index in Array (LSB)**”, “**Receive Bit Index in Byte (LSB)**”, “**Receive Resolution**” and “**Receive Offset**” can all be use to map any SPN supported by the J1939 standard to the output data of the Received function block. The defaults used by the 2oPi are all for proprietary SPNs, and are defined in detail in Section 3.4.

Note: Output Data = CAN Data * Resolution + Offset

As mentioned earlier, a CAN Receive function block can be selected as the source of the control input for the output function blocks. When this is the case, the “**Received Data Min (Off Threshold)**” and “**Received Data Max (On Threshold)**” setpoints become the minimum and maximum values of the X-axis used in the linear calculations. As the names imply, they are also used as the On/Off thresholds for digital input types. These values are in whatever units the output data is AFTER the resolution and offset is applied to the CAN data.

The 2oPi supports up to 8 unique CAN Receive Messages. By default, each message is pre-configured to read a particular type of data. The details are outlined in Section 3.4, and the default list is shown in Table 15 below.

Block #	Default Receive Data
1	Output 1 Command Input Data
2	Output 2 Command Input Data
3	Output 1 Closed Loop Feedback
4	Output 2 Closed Loop Feedback
5	Output 1 Enable Input Data
6	Output 2 Enable Input Data
7	Output 1 Override Input Data
8	Output 2 Override Input Data

Table 15 – Default CAN Receive Messages

1.11. Available Control/Input Sources

Throughout Section 1, there have been numerous mentions of ‘mapping’ an output of one function block to a control or input of another. Any time an input is programmable, as shown by the green bubbles in the figures above, it consists of two setpoints. One is the “[Name] Source” and the other the “[Name] Number.” Together, these two setpoints uniquely select how the I/O of the various function blocks are linked together in the custom application.

Below is the full list of the programmable inputs supported by the 2oPi.

Function Block	Input Name
Output X Drive (where X =1 to 2)	Control
	Enable
	Override
PID Control X (where X =1 to 2)	PID Target Command
	PID Feedback Input
Lookup Table X (where X = 1 to 8)	X-Axis
Programmable Logic	Table 1 – Lookup Table Block Number
	Table 1 – Condition 1, Argument 1
	Table 1 – Condition 1, Argument 2
	Table 1 – Condition 2, Argument 1
	Table 1 – Condition 2, Argument 2
	Table 1 – Condition 3, Argument 1
	Table 1 – Condition 3, Argument 2
	Table 2 – Lookup Table Block Number
	Table 2 – Condition 1, Argument 1
	Table 2 – Condition 1, Argument 2
	Table 2 – Condition 2, Argument 1
	Table 2 – Condition 2, Argument 2
	Table 2 – Condition 3, Argument 1
	Table 2 – Condition 3, Argument 2
	Table 3 – Lookup Table Block Number
	Table 3 – Condition 1, Argument 1
	Table 3 – Condition 1, Argument 2
	Table 3 – Condition 2, Argument 1
	Table 3 – Condition 2, Argument 2
	Table 3 – Condition 3, Argument 1
Table 3 – Condition 3, Argument 2	
Math Function X (where X = 1 to 4)	Input 1, Input 2, Input 3 and Input 4
CAN Transmit X (where X = 1 to 8)	Transmit Data

Table 16 – Programmable Inputs

For each of the inputs listed in Table 16, the options for the Source and Number are listed below. Note, not all options would make sense for any particular input, and it is up to the user to program the controller in a logical and functional fashion.

Sources	Range	Notes
Control Source Not Used	N/A	When this is selected, it disables all other setpoints associated with the input in question.
Received CAN J1939 Message	1 to 8	The CAN Receive Messages each have a unique default assigned to them as outlined in Section 1.10
PID Function Block	1 to 2	User must enable the function block, as it is disabled by default
Lookup Table Function Block	1 to 8	User must enable the function block, as it is disabled by default
Programmable Logic Function Block	1 to 4	User must enable the function block, as it is disabled by default
Math Function Block	1 to 4	User must enable the function block, as it is disabled by default
Control Constant Data	1 to 14	1 = Always FALSE, 2 = Always TRUE, 3 to 14 = User Selectable
Diagnostic Trouble Code (Rxd)	1 to 4	Will only be valid if the corresponding DTC has a non-zero SPN
Note: Control sources below this line are meant for feedback and diagnostics, and are not suitable for use as controls for other logic blocks		
Universal Output Target Value	1 to 2	Can be mapped to a CAN Txd
Universal Output Feedback Value	1 to 2	Input to Output X Drive Diagnostics Can be mapped to a CAN Txd
Power Supply Measured	N/A	Input to Power Supply Diagnostics Can be mapped to a CAN Txd
Processor Temperature Measured	N/A	Input to Over Temperature Diagnostics Can be mapped to a CAN Txd

Table 17 – Input Sources and Numbers

1.12. Default Valve Controller Program Logic

Below is shown an **extremely** simplified block diagram illustrating the default control logic programmed into the 2oPi.

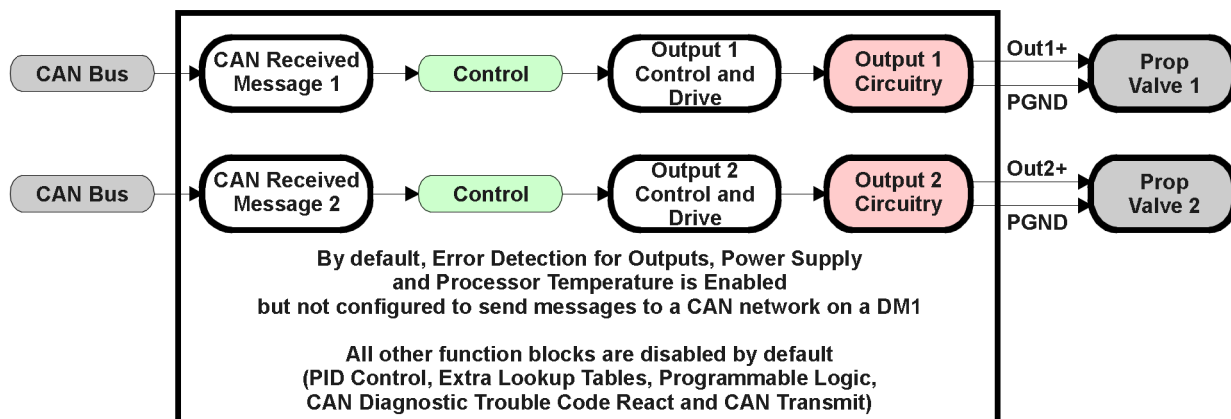

Figure 24 – Default Control Logic

2. INSTALLATION INSTRUCTIONS

2.1. Dimensions and Pinout

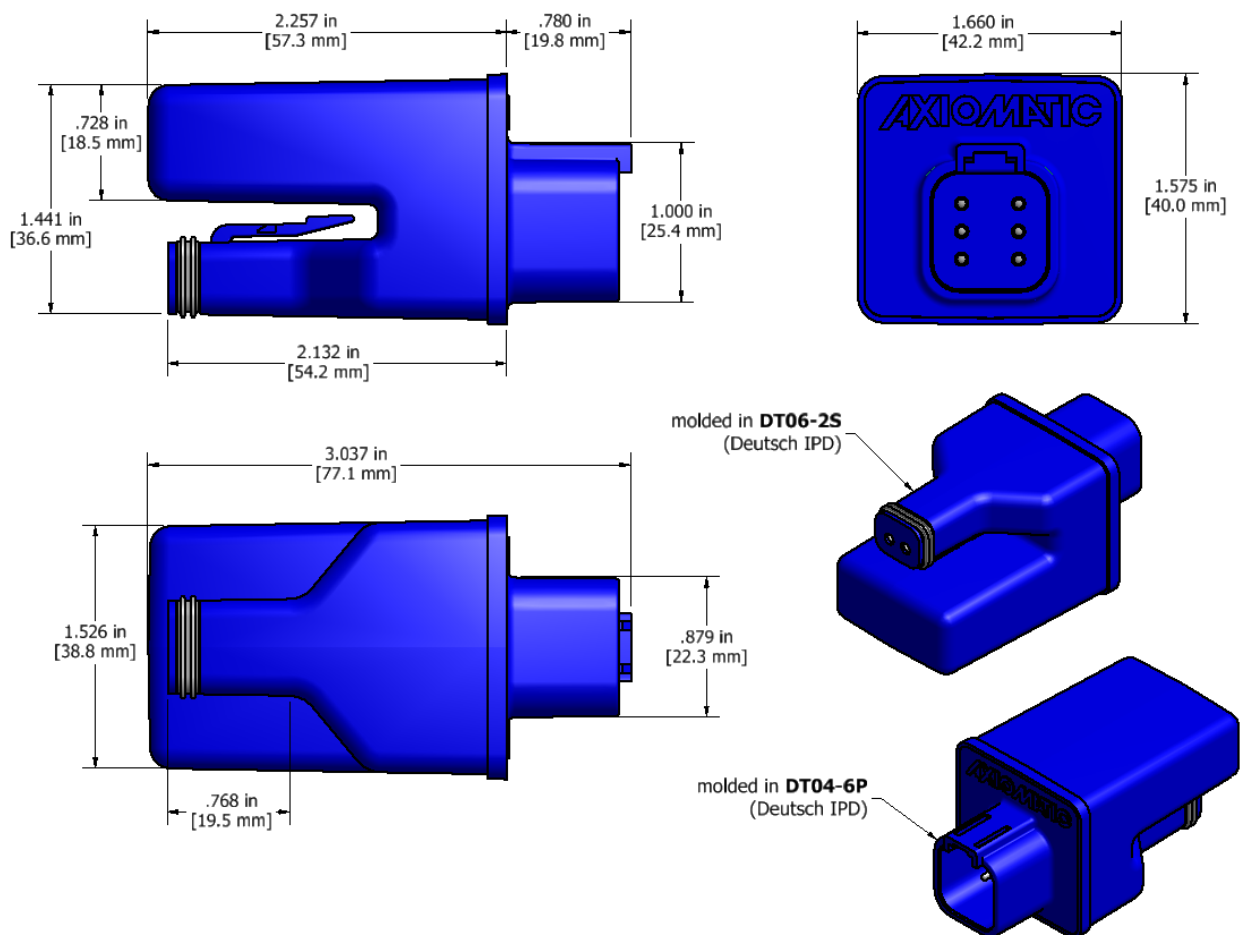

Figure 25 – Dimension Drawing

6-pin Connector	
Pin #	Description (Notes)
1	Solenoid B-
2	CAN H
3	CAN L
4	Power +
5	Power -
6	Solenoid B+

2-pin Connector	
Pin #	Description (Notes)
1	Solenoid A+
2	Solenoid A-

Table 18 – Connector Pinout

2.2. Mounting Instructions

NOTES & WARNINGS

- Do not install near high-voltage or high-current devices.
- Note the operating temperature range. All field wiring must be suitable for that temperature range.
- Install the unit with appropriate space available for servicing and for adequate wire harness access (15 cm) and strain relief (30 cm).
- Do not connect or disconnect the unit while the circuit is live, unless the area is known to be non-hazardous.

MOUNTING

The module is designed for mounting on the valve block. If it is mounted without an enclosure, the controller should be mounted horizontally with connectors facing left or right, or with the connectors facing down, to reduce likelihood of moisture entry.

Mask all labels if the unit is to be repainted, so label information remains visible.

Mounting legs include holes sized for up to ¼-20 or M6 bolts. The bolt length will be determined by the end-user's mounting plate thickness. Typically 20 mm (¾ inch) is adequate.

If the module is mounted away from the valve block, no wire or cable in the harness should exceed 30 meters in length. The power input wiring should be limited to 10 meters.

CONNECTIONS

Use the following TE Deutsch mating plugs to connect to the integral receptacles. Wiring to these mating plugs must be in accordance with all applicable local codes. Suitable field wiring for the rated voltage and current must be used. The rating of the connecting cables must be at least 85°C. For ambient temperatures below -10°C and above +70°C, use field wiring suitable for both minimum and maximum ambient temperature.

Mating Connector	DT06-12SA and wedge W12S
Sockets	0462-201-16141 or acceptable alternate Refer to www.laddinc.com for more information on the contacts available for this mating plug.

NOISE – ELECTRICAL CONNECTIONS AND SHIELDING

To reduce noise, separate all power and output wires from those of the input and CAN. Shielded wires will protect against injected noise. Shield wires should be connected at the power or input source, or at the output load.

All wires used must be 16 or 18 AWG.

CAN NETWORK CONSTRUCTION

Axiomatic recommends that multi-drop networks be constructed using a “daisy chain” or “backbone” configuration with short drop lines.

CAN TERMINATION

It is necessary to terminate the network; therefore, an external CAN termination is required. No more than two network terminators should be used on any one single network. A terminator is a 121Ω, 0.25 W, 1% metal film resistor placed between CAN_H and CAN_L terminals at the end two nodes on a network.

3. OVERVIEW OF J1939 FEATURES

The software was designed to provide flexibility to the user with respect to messages sent to and from the ECU by providing:

- Configurable ECU Instance in the NAME (to allow multiple ECUs on the same network)
- Configurable Transmit PGN and SPN Parameters
- Configurable Receive PGN and SPN Parameters
- Sending DM1 Diagnostic Message Parameters
- Reading and reacting to DM1 messages sent by other ECUs
- Diagnostic Log, maintained in non-volatile memory, for sending DM2 messages

3.1. Introduction To Supported Messages

The ECU is compliant with the standard SAE J1939, and supports the following PGNs

From J1939-21 - Data Link Layer

- | | |
|---|------------------|
| • Request | 59904 (\$00EA00) |
| • Acknowledgment | 59392 (\$00E800) |
| • Transport Protocol – Connection Management | 60416 (\$00EC00) |
| • Transport Protocol – Data Transfer Message | 60160 (\$00EB00) |
| • PropB Transmit, Default Measured Inputs Feedback Message | 65280 (\$00FF00) |
| • PropB Transmit, Default Proportional Outputs Target Message | 65296 (\$00FF10) |
| • PropB Transmit, Default Proportional Outputs Feedback Message | 65312 (\$00FF20) |
| • PropB Transmit, Default Digital I/O State Feedback Message | 65328 (\$00FF30) |
| • PropB Receive, Default Output Control Data Message | 65408 (\$00FF80) |
| • PropB Receive, Default Output Enable Data Message | 65424 (\$00FF90) |
| • PropB Receive, Default Output Override Data Message | 65440 (\$00FFA0) |
| • PropB Receive, Default PID Feedback Data Message | 65456 (\$00FFB0) |

Note: Any Proprietary B PGN in the range 65280 to 65535 (\$00FF00 to \$00FFFF) can be selected

Note: The Proprietary A PGN 61184 (\$00EF00) can also be selected for any of the messages

From J1939-73 - Diagnostics

- | | |
|--|------------------|
| • DM1 – Active Diagnostic Trouble Codes | 65226 (\$00FECA) |
| • DM2 – Previously Active Diagnostic Trouble Codes | 65227 (\$00FECB) |
| • DM3 – Diagnostic Data Clear/Reset for Previously Active DTCs | 65228 (\$00FECC) |
| • DM11 - Diagnostic Data Clear/Reset for Active DTCs | 65235 (\$00FED3) |
| • DM14 – Memory Access Request | 55552 (\$00D900) |
| • DM15 – Memory Access Response | 55296 (\$00D800) |
| • DM16 – Binary Data Transfer | 55040 (\$00D700) |

From J1939-81 - Network Management

- | | |
|--------------------------------|------------------|
| • Address Claimed/Cannot Claim | 60928 (\$00EE00) |
| • Commanded Address | 65240 (\$00FED8) |

From J1939-71 – Vehicle Application Layer

- | | |
|---------------------------|------------------|
| • Software Identification | 65242 (\$00FEDA) |
|---------------------------|------------------|

None of the application layer PGNs are supported as part of the default configurations, but they can be selected as desired for either transmit or received function blocks.

Setpoints are accessed using standard Memory Access Protocol (MAP) with proprietary addresses. The Axiomatic Electronic Assistant (EA) allows for quick and easy configuration of the unit over the CAN network.

3.2. NAME, Address and Software ID

J1939 NAME

The 2oPi ECU has the following defaults for the J1939 NAME. The user should refer to the SAE J1939/81 standard for more information on these parameters and their ranges.

Arbitrary Address Capable	Yes
Industry Group	0, Global
Vehicle System Instance	0
Vehicle System	0, Non-specific system
Function	66, I/O Controller
Function Instance	26, Axiomatic AX022310, Dual Input, Dual Output
ECU Instance	0, First Instance
Manufacture Code	162, Axiomatic Technologies Corporation
Identity Number	Variable, uniquely assigned during factory programming for each ECU

The ECU Instance is a configurable setpoint associated with the NAME. Changing this value will allow multiple ECUs of this type to be distinguishable by other ECUs (including the Axiomatic Electronic Assistant) when they are all connected on the same network.

ECU Address

The default value of this setpoint is 128 (0x80), which is the preferred starting address for self-configurable ECUs as set by the SAE in J1939 tables B3 to B7. The Axiomatic EA supports the selection of any address between 0 to 253, and ***it is the user's responsibility to select an address that complies with the standard.*** The user must also be aware that since the unit is arbitrary address capable, if another ECU with a higher priority NAME contends for the selected address, the 2oPi will continue select the next highest address until it finds one that it can claim. See J1939/81 for more details about address claiming.

Software Identifier

PGN 65242	Software Identification	- SOFT	
Transmission Repetition Rate:	On request		
Data Length:	Variable		
Extended Data Page:	0		
Data Page:	0		
PDU Format:	254		
PDU Specific:	218 PGN Supporting Information:		
Default Priority:	6		
Parameter Group Number:	65242 (0xFEDA)		
Start Position	Length	Parameter Name	SPN
1	1 Byte	Number of software identification fields	965
2-n	Variable	Software identification(s), Delimiter (ASCII “**”)	234

For the 2oPi ECU, Byte 1 is set to 5, and the identification fields are as follows

(Part Number)*(Version)*(Date)*(Owner)*(Description)

The Axiomatic EA shows all this information in “General ECU Information”, as shown below:

The screenshot shows the 'Electronic Assistant' window with a tree view on the left and a data table on the right. The tree view shows a 'J1939 CAN Network' containing an 'ECU AX022310, CAN with Dual 2.5A Output'. Under this ECU, the 'General ECU Information' section is expanded. The data table on the right lists various parameters and their values.

Parameter	Value	Description
ECU Part Number	AX022310	
ECU Serial Number	0012113004	
ECU J1939 NAME		
Arbitrary Address Capable	0X01	Yes
Industry Group	0X00	Global
Vehicle System Instance	0X00	
Vehicle System	0X00	Non-specific system
Reserved	0X00	
Function	0X42	I/O Controller
Function Instance	0X1B	
ECU Instance	0X00	#1 - First Instance
Manufacturer Code	0X0A2	Axiomatic Technolog
Identity Number	0X0AD4AA	Unique ECU network
ECU Address	0X80	Reserved for future
ECU ID	N/A	PGN 64965 -ECUID
Software ID		
Field #1	AX022310	
Field #2	V1.00	
Field #3	JUN 13, 2013	
Field #4	Axiomatic Technologies Corp.	
Field #5	CAN, Dual 2.5A Outputs, Plug-In	

Note: The information provided in the Software ID is available for any J1939 service tool which supports the PGN -SOFT.

3.3. CAN Transmit Message Defaults

This section outlines the **default** settings of the 2oPi CAN transmissions. Recall, however, that this is a fully programmable unit, such that all these SPNs can be sent on different PGNs if so desired.

In all the messages shown below, not all the transmitted values have an SPN assigned to them, as this ECU only uses the SPNs for diagnostic trouble codes. If the SPN is shown as N/A, this means that the associated value cannot be used to generate DTCs.

The “Proportional Outputs Message” has the following default configuration.

PGN 65280		Proportional Outputs Feedback	
Transmission Repetition:		0s (not sent by default, configurable)	
Data Length:		8	
Data Page:		0	
PDU Format:		254	
PDU Specific:		GE	PGN Supporting Information:
Default Priority:		6	
Parameter Group Number:		65280 (0xFF00)	
Start Position	Length	Parameter Name	SPN
1-2	2 byte	Universal Output 1 Current Feedback	520448
3-4	2 byte	Universal Output 2 Current Feedback	520449
5-8	4 byte	Not Used	N/A

Universal Output X Current Feedback, where X = 1 to 2

This value reflects the measured current sourced from the proportional output drive circuit. For non-current “Output Type” selections, this value will reflect the actual value being applied to the output port.

Data Length: 2 byte
Resolution: 1mA/bit, 0 offset
Data Range: 0 to 64255 mA
Type: Measured
Suspect Parameter Number: 520448 to 520449 (0x7F100 to 0x7F101, proprietary SPNs)
Parameter Group Number: 65280

3.4. CAN Receive Message Defaults

This section outlines the **default** settings of the 2oPi CAN receive channels, used as inputs to the various function blocks supported by this ECU. Recall, however, that this is a fully programmable unit, such that all these SPNs can be received on different PGNs if so desired.

In all the messages shown below, none of the received values have an SPN assigned to them, as this ECU only uses the SPNs for diagnostic trouble codes. To have the 2oPi react to a DTC sent by another ECU on the network on a DM1, use the DTC React Function block instead.

By default, all but the first two CAN Receive Messages are disabled, as they are not part of the factory set logic shown in Figure 24. However, should any of them be enabled by the user, the default settings for each message are as outlined in this section.

The “Output Control Data Message” has the following default configuration.

PGN 65408		Output Control Data	
Transmission Repetition:	100ms (default, configurable)		
Data Length:	8		
Data Page:	0		
PDU Format:	254		
PDU Specific:	GE	PGN Supporting Information:	
Default Priority:	6		
Parameter Group Number:	65408 (0xFF80)		
Start Position	Length	Parameter Name	SPN
1	1 byte	Output 1 Command Input Data	N/A
2	1 byte	Output 2 Command Input Data	N/A
3	1 byte	Output 1 Closed Loop Feedback	N/A
4	1 byte	Output 2 Closed Loop Feedback	N/A
5	1 byte	Output 1 Enable Input Data	N/A
6	1 byte	Output 2 Enable Input Data	N/A
7	1 byte	Output 1 Override Input Data	N/A
8	1 byte	Output 2 Override Input Data	N/A

Output X Command Input Data, where X = 1 to 2

Default value used when a ‘Received CAN J1939 Message’ is used as the control source for the Output Control logic function block (or another block that is linked to the output control.)

Data Length: 1 byte
 Resolution: 0.4%/bit, 0 offset
 Data Range: 0 to 100 %
 Type: Input
 Suspect Parameter Number: N/A
 Parameter Group Number: 65408

Output X Closed Loop Feedback, where X = 1 to 2

Default value used when a 'Received CAN J1939 Message' is used as the feedback source for a proportional output PID control function block.

Data Length: 1 byte
Resolution: 0.4 [Data]/bit, 0 offset
Data Range: 0 to 100.0
Type: Input
Suspect Parameter Number: N/A
Parameter Group Number: 65408

Output X Enable Input Data, where X = 1 to 2

Default value used when a 'Received CAN J1939 Message' is used as an enable source for the Output Control logic function block.

- 00 Enable Signal is OFF
- 01 Enable Signal is ON
- 02 Error (automatic disable)
- 03+ Ignored

Data Length: 2 bits
Resolution: 1 state/bit, 0 offset
Type: Input
Suspect Parameter Number: N/A
Parameter Group Number: 65408

Output X Override Input Data, where X = 1 to 2

Default value used when a 'Received CAN J1939 Message' is used as the override source for the Output Control logic function block.

- 00 Override Signal is OFF
- 01 Override Signal is ON
- 02 Error (override disabled)
- 03+ Ignored

Data Length: 2 bits
Resolution: 1 state/bit, 0 offset
Type: Input
Suspect Parameter Number: N/A
Parameter Group Number: 65408

4. ECU SETPOINTS ACCESSED WITH THE AXIOMATIC EA

Many setpoints have been referenced throughout this manual. This section describes in detail each setpoint, and their defaults and ranges. For more information on how each setpoint is used by the 2oPi, refer to the relevant section of the User Manual.

4.1. Miscellaneous Setpoints

The Miscellaneous setpoints primarily deal with the CAN Network. Refer to the notes for more information about each setpoint.

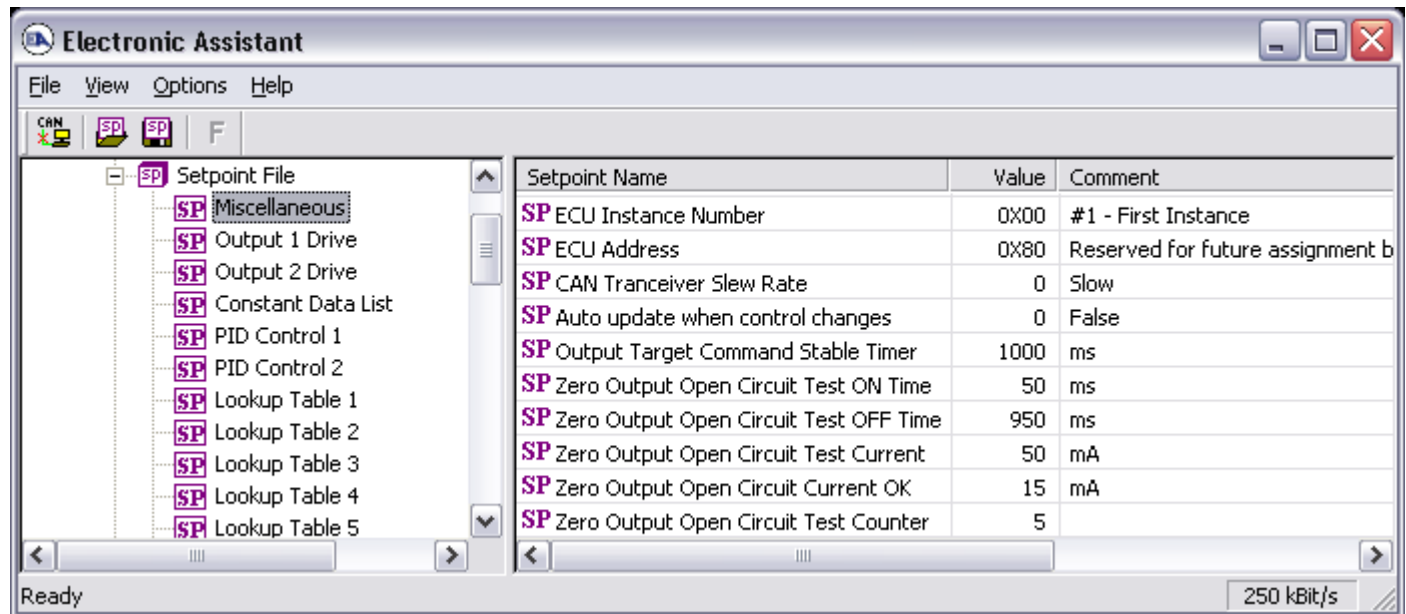

Screen Capture of Default Miscellaneous Setpoints

Name	Range	Default	Notes
ECU Instance Number	Drop List	0, #1 – First Instance	Per J1939-81
ECU Address	0 to 253	128 (0x80)	Preferred address for a self-configurable ECU
CAN Transceiver Slew Rate	0 to 1	Slow or Fast	A fast slew rate allows for better transmission over long CAN bus wires, but it can also increase the noise emitted on an unshielded network.
Auto update when control changes	0, False 1, True	0, False	When True, any change to a logic block that is used as a control source for another logic block will cause the block using the source as an input to automatically be updated with the new range. Use this feature with caution as it will cause any previous changes to the controlled block to be overwritten.
Output Target Command Stable Timer	1 to 1000 [ms]	1000 [ms]	See Section 1.2 “Open or Short Circuits” for more information on how these setpoints are used.
Zero Output Open Circuit Test ON Time	1 to 1000 [ms]	50 [ms]	
Zero Output Open Circuit Test OFF Time	1 to 1000 [ms]	950 [ms]	
Zero Output Open Circuit Test Current	0 to 200 [mA]	50 [mA]	
Zero Output Open Circuit Current OK	1 to 200 [mA]	15 [mA]	
Zero Output Open Circuit Test Counter	1 to 10	5	

If non-default values for the “**ECU Instance Number**” or “**ECU Address**” are used, they will be mirrored during a setpoint file flashing, and will only take effect once the entire file has been downloaded to the unit. After the setpoint flashing is complete, the unit will claim the new address and/or re-claim the address with the new NAME. If these setpoints are changing, it is recommended to close and re-open the CAN connection on the Axiomatic EA after the file is loaded, such that only the new NAME and address appear in the J1939 CAN Network ECU list.

4.2. Output Drive Setpoints

The Output Drive function block is defined in Section 1.2. Please refer there for detailed information about how all these setpoints are used.

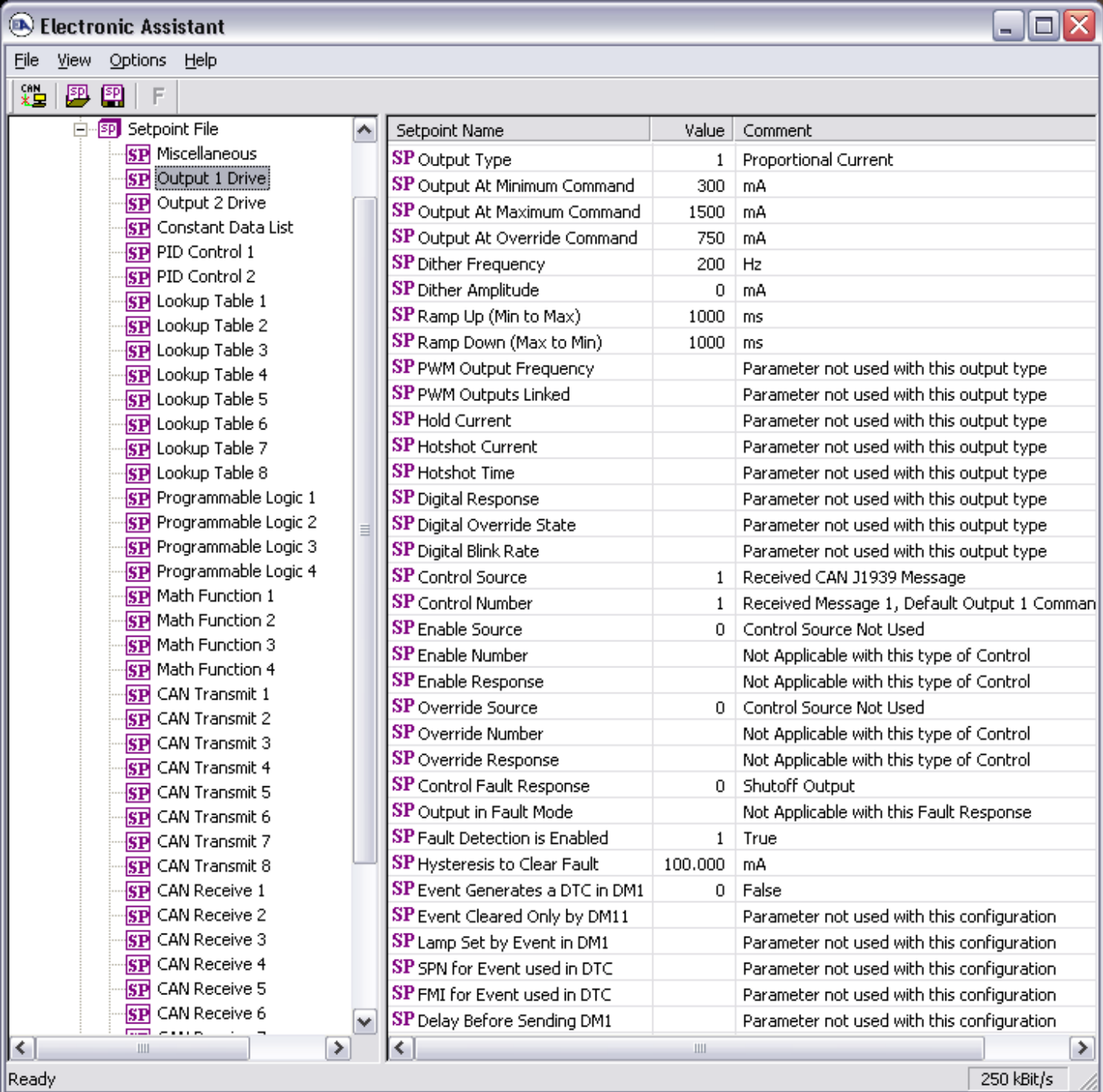

The screenshot shows the 'Electronic Assistant' software window. On the left, a tree view under 'Setpoint File' has 'Output 1 Drive' selected. On the right, a table lists the setpoints for this drive.

Setpoint Name	Value	Comment
SP Output Type	1	Proportional Current
SP Output At Minimum Command	300	mA
SP Output At Maximum Command	1500	mA
SP Output At Override Command	750	mA
SP Dither Frequency	200	Hz
SP Dither Amplitude	0	mA
SP Ramp Up (Min to Max)	1000	ms
SP Ramp Down (Max to Min)	1000	ms
SP PWM Output Frequency		Parameter not used with this output type
SP PWM Outputs Linked		Parameter not used with this output type
SP Hold Current		Parameter not used with this output type
SP Hotshot Current		Parameter not used with this output type
SP Hotshot Time		Parameter not used with this output type
SP Digital Response		Parameter not used with this output type
SP Digital Override State		Parameter not used with this output type
SP Digital Blink Rate		Parameter not used with this output type
SP Control Source	1	Received CAN J1939 Message
SP Control Number	1	Received Message 1, Default Output 1 Comman
SP Enable Source	0	Control Source Not Used
SP Enable Number		Not Applicable with this type of Control
SP Enable Response		Not Applicable with this type of Control
SP Override Source	0	Control Source Not Used
SP Override Number		Not Applicable with this type of Control
SP Override Response		Not Applicable with this type of Control
SP Control Fault Response	0	Shutoff Output
SP Output in Fault Mode		Not Applicable with this Fault Response
SP Fault Detection is Enabled	1	True
SP Hysteresis to Clear Fault	100.000	mA
SP Event Generates a DTC in DM1	0	False
SP Event Cleared Only by DM11		Parameter not used with this configuration
SP Lamp Set by Event in DM1		Parameter not used with this configuration
SP SPN for Event used in DTC		Parameter not used with this configuration
SP FMI for Event used in DTC		Parameter not used with this configuration
SP Delay Before Sending DM1		Parameter not used with this configuration

Screen Capture of Default Output 1 Drive Setpoints

Name	Range	Default	Notes
Output Type	Drop List	1, Proportional Current	See Table 10
Output at Minimum Command	0 to Limit	300 mA	Current, Limit = 3000 mA Voltage, Limit = 48.0V PWM, Limit = 100.0 %
Output at Maximum Command	0 to Limit	1500 mA	
Output at Override Command	0 to Limit	750 mA	
Dither Frequency	50 to 400 Hz	200 Hz	
Dither Amplitude	0 to 500 mA	0 mA	0 = No Dithering
Ramp Up (Min to Max)	0 to 10,000 ms	1000 ms	
Ramp Down (Max to Min)	0 to 10,000 ms	1000 ms	
PWM Output Frequency	1Hz to 25,000 Hz	500Hz	Only configurable if no current output types are enabled for any output.
PWM Outputs Linked	False or True	False	Only configurable on Output 1 in PWM mode
Hold Current	0 to 2500 mA	500 mA	Only used with Hotshot output type
Hotshot Current	0 to 2500 mA	2000 mA	
Hotshot Time	500 to 10,000 ms	1000 ms	
Digital Response	Drop List	0, Normal On/Off	See Table 11
Digital Override State	0 or 1	1, ON	
Digital Blink Rate	100 to 5000 ms	1000 ms	Only used with 'Blinking' response
Control Source	Drop List	1, Received CAN J1939 Message	See Table 17
Control Number	Per Source	Same as Output Drive Number	See Table 17
Enable Source	Drop List	0, Control Source Not Used	See Table 17
Enable Number	Per Source	N/A	See Table 17
Enable Response	Drop List	N/A	See Table 1
Override Source	Drop List	0, Control Source Not Used	See Table 17
Override Number	Per Source	N/A	See Table 17
Override Response	Drop List	N/A	0 = Override When On 1 = Override When Off
Control Fault Response	Drop List	0, Shutoff Output	See Table 2
Output in Fault Mode	Depends on Output Type	500 mA	See limits on ranges per output type outlined above
Fault Detection is Enabled	False or True	True	See Section 1.2 and 1.7
Hysteresis to Clear Fault	0.01 to 250.00	100.00 mA	See Section 1.2 and 1.7
Event Generates a DTC in DM1	False or True	False	See Section 1.7
Event Cleared Only by DM11	False or True	False	See Section 1.7
Lamp Set by Event in DM1	Drop List	1, Amber, Warning	See Section 1.7
SPN for Event used in DTC	1 to 524287	520448 (\$7F100) 520449 (\$7F101)	Out1 Out2 See Section 1.7 and 3.3
FMI for Event used in DTC	Drop List	5, Open Circuit	See Section 1.7 (low FMI)
Delay Before Sending DM1	0 to 60,000 ms	1000 ms	See Section 1.7

4.3. Constant Data List Setpoints

The Constant Data List function block is provided to allow the user to select values as desired for various logic block functions. Throughout this manual, various references have been made to constants, as summarized in the examples listed below.

- a) PID Control: Constant **“PID Target Command”** in a *‘Setpoint Control’* application
- b) Programmable Logic: Constant **“Table X = Condition Y, Argument 2”**, where X and Y = 1 to 3
- c) Math Function: Constant **“Math Input X”**, where X = 1 to 4

The first two constants are fixed values of 0 (False) and 1 (True) for use in binary logic. The remaining 12 constants are fully user programmable to any value between +/- 1,000,000. The default values (shown below) are arbitrary and should be configured by the user as appropriate for their application.

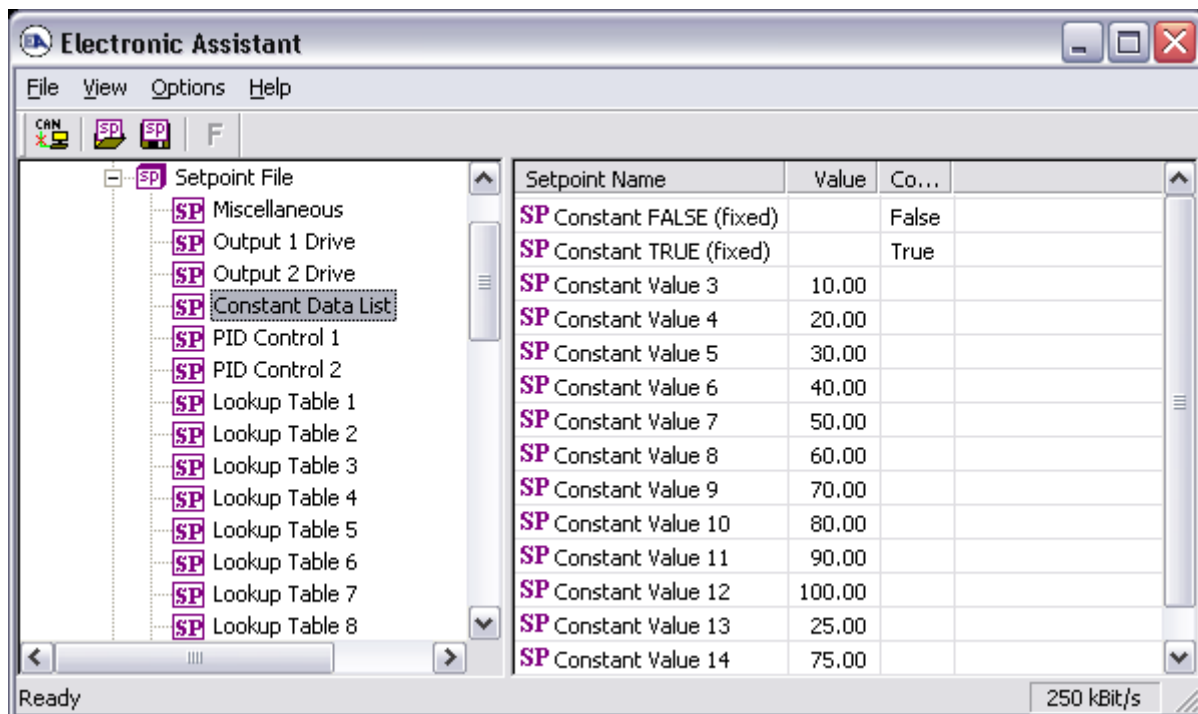

Screen Capture of Default Constant Data List Setpoints

4.4. PID Control

The PID Control function block is defined in Section 1.3. Please refer there for detailed information about how all these setpoints are used.

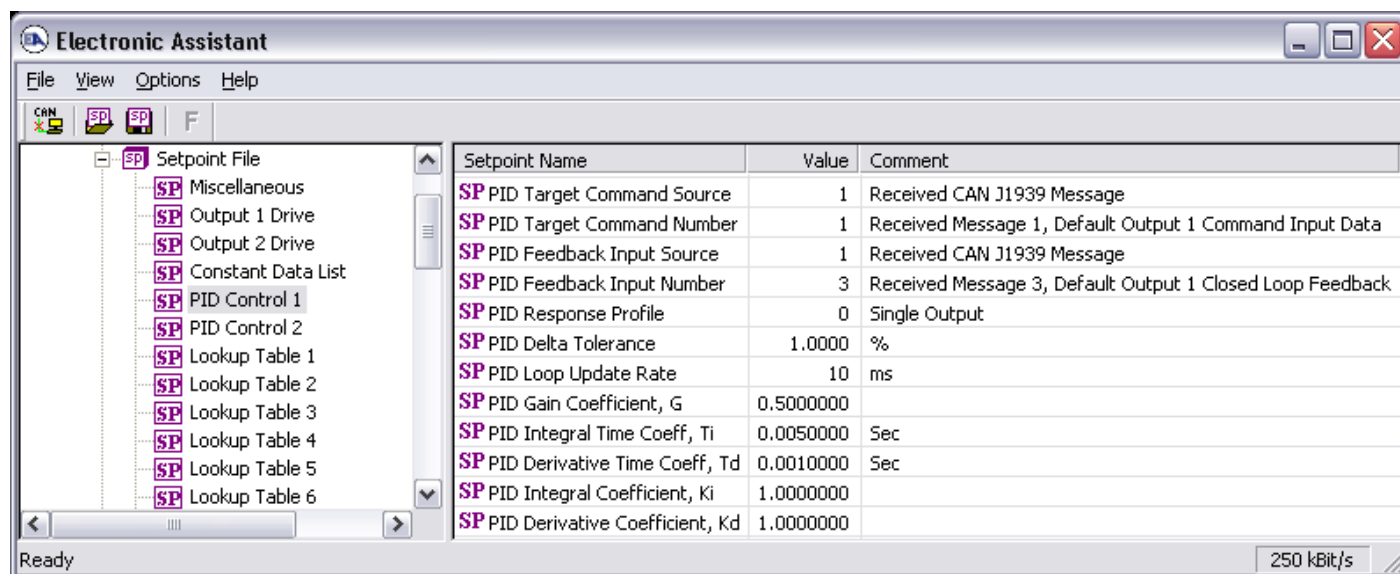

Screen Capture of Default PID Control 1 Setpoints

Note: In the screen capture shown above, the “PID Target Command Source” has been changed from its default value in order to enable the function block.

Name	Range	Default	Notes
PID Target Command Source	Drop List	0, Control Source Not Used	See Table 17
PID Target Command Number	Per Source	1, Receive Message 1 2, Receive Message 2	PID1 PID2 See Table 17
PID Feedback Input Source	Drop List	1, Received CAN J1939 Message	See Table 17
PID Feedback Input Number	Per Source	3, Receive Message 3 4, Receive Message 4	PID1 PID2 See Table 17
PID Response Profile	Drop List	0, Single Output	See Table 5
PID Delta Tolerance	0 to 100	1.00	%
PID Loop Update Rate	1 to 60,000 ms	10 ms	1 ms resolution
PID Gain Coefficient, G	0.1 to 10	0.5	See Figure 10
PID Integral Time Coeff, Ti	0.001 to 10 Sec	0.005 Sec	0.001 Sec (1ms) resolution
PID Derivative Time Coeff, Td	0.001 to 10 Sec	0.001 Sec	0.001 Sec (1ms) resolution
PID Integral Coefficient, Ki	0 to 10	1.0	0 disables integral, PD ctrl
PID Derivative Coefficient, Kd	0 to 10	1.0	0 disables derivative, PI ctrl

4.5. Lookup Table Setpoints

The Lookup Table function block is defined in Section 1.4. Please refer there for detailed information about how all these setpoints are used. As this function block's X-Axis defaults are defined by the **"X-Axis Source"** selected from Table 17, there is nothing further to define in terms of defaults and ranges beyond that which is described in Section 1.4. Recall, the X-Axis values will be automatically updated if the min/max range of the selected source is changed.

Setpoint Name	Value	Comment
SP X-Axis Source	1	Received CAN J1939 Message
SP X-Axis Number	1	Received Message 1, Default Output 1 Command Input Data
SP X-Axis Type	0	Data Response
SP Point 1 - Response	1	Ramp To
SP Point 2 - Response	1	Ramp To
SP Point 3 - Response	1	Ramp To
SP Point 4 - Response	1	Ramp To
SP Point 5 - Response	1	Ramp To
SP Point 6 - Response	1	Ramp To
SP Point 7 - Response	1	Ramp To
SP Point 8 - Response	1	Ramp To
SP Point 9 - Response	1	Ramp To
SP Point 10 - Response	1	Ramp To
SP Point 0 - X Value	0.000	
SP Point 1 - X Value	10.000	
SP Point 2 - X Value	20.000	
SP Point 3 - X Value	30.000	
SP Point 4 - X Value	40.000	
SP Point 5 - X Value	50.000	
SP Point 6 - X Value	60.000	
SP Point 7 - X Value	70.000	
SP Point 8 - X Value	80.000	
SP Point 9 - X Value	90.000	
SP Point 10 - X Value	100.000	
SP Point 0 - Y Value	0.000	
SP Point 1 - Y Value	10.000	
SP Point 2 - Y Value	20.000	
SP Point 3 - Y Value	30.000	
SP Point 4 - Y Value	40.000	
SP Point 5 - Y Value	50.000	
SP Point 6 - Y Value	60.000	
SP Point 7 - Y Value	70.000	
SP Point 8 - Y Value	80.000	
SP Point 9 - Y Value	90.000	
SP Point 10 - Y Value	100.000	

Screen Capture of Example Lookup Table 1 Setpoints

Note: In the screen capture shown above, the "X-Axis Source" has been changed from its default value in order to enable the function block.

4.6. Programmable Logic Setpoints

The Programmable Logic function block is defined in Section 1.5. Please refer there for detailed information about how all these setpoints are used.

As this function block is disabled by default, there is nothing further to define in terms of defaults and ranges beyond that which is described in Section 1.5. The screen capture below shows how the setpoints referenced in that section appear on the Axiomatic EA.

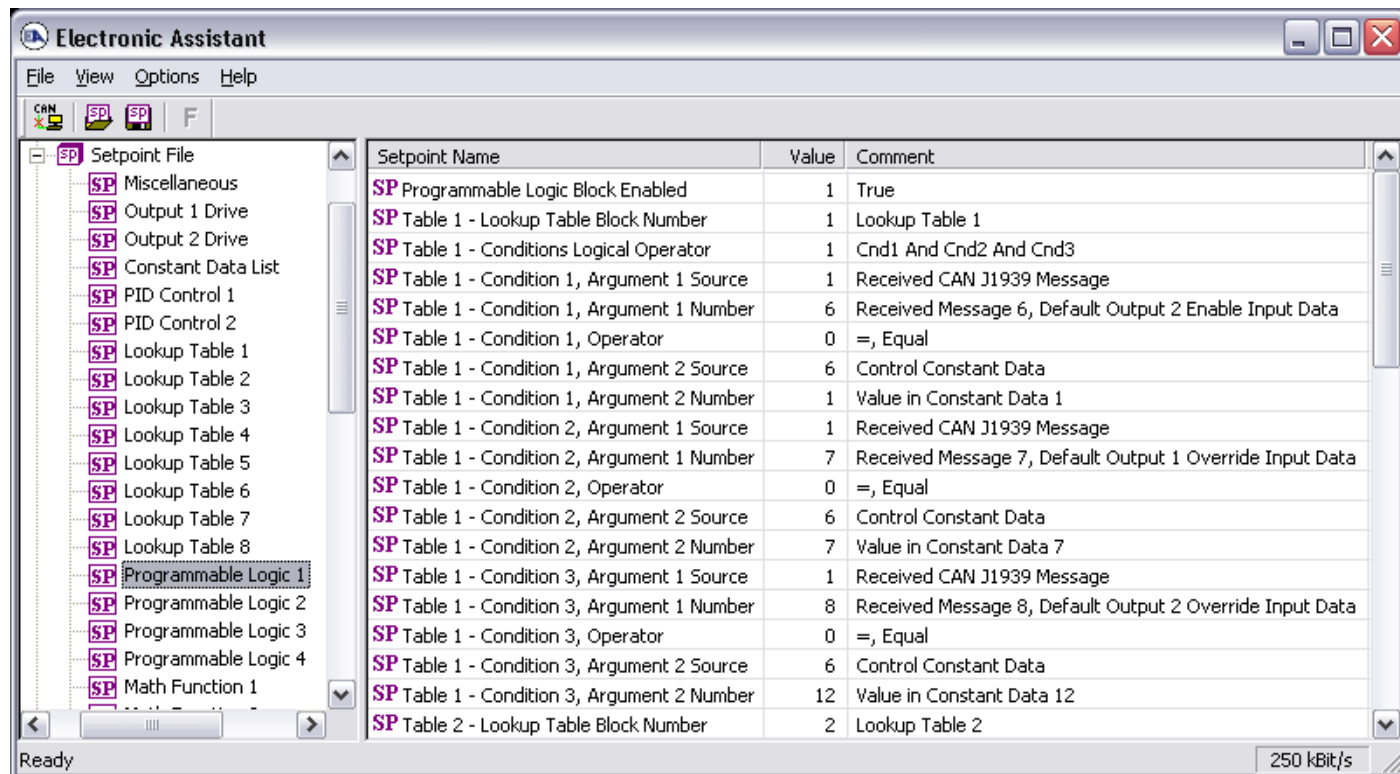

Setpoint Name	Value	Comment
SP Programmable Logic Block Enabled	1	True
SP Table 1 - Lookup Table Block Number	1	Lookup Table 1
SP Table 1 - Conditions Logical Operator	1	Cnd1 And Cnd2 And Cnd3
SP Table 1 - Condition 1, Argument 1 Source	1	Received CAN J1939 Message
SP Table 1 - Condition 1, Argument 1 Number	6	Received Message 6, Default Output 2 Enable Input Data
SP Table 1 - Condition 1, Operator	0	=, Equal
SP Table 1 - Condition 1, Argument 2 Source	6	Control Constant Data
SP Table 1 - Condition 1, Argument 2 Number	1	Value in Constant Data 1
SP Table 1 - Condition 2, Argument 1 Source	1	Received CAN J1939 Message
SP Table 1 - Condition 2, Argument 1 Number	7	Received Message 7, Default Output 1 Override Input Data
SP Table 1 - Condition 2, Operator	0	=, Equal
SP Table 1 - Condition 2, Argument 2 Source	6	Control Constant Data
SP Table 1 - Condition 2, Argument 2 Number	7	Value in Constant Data 7
SP Table 1 - Condition 3, Argument 1 Source	1	Received CAN J1939 Message
SP Table 1 - Condition 3, Argument 1 Number	8	Received Message 8, Default Output 2 Override Input Data
SP Table 1 - Condition 3, Operator	0	=, Equal
SP Table 1 - Condition 3, Argument 2 Source	6	Control Constant Data
SP Table 1 - Condition 3, Argument 2 Number	12	Value in Constant Data 12
SP Table 2 - Lookup Table Block Number	2	Lookup Table 2

Screen Capture of Default Programmable Logic 1 Setpoints

Note: In the screen capture shown above, the “Programmable Logic Block Enabled” has been changed from its default value in order to enable the function block.

Note: The default values for the Argument1, Argument 2 and Operator are all the same across all the Programmable Logic function blocks, and must therefore be changed by the user as appropriate before this can be used.

4.7. Math Function Setpoints

The Math Function block is defined in Section 1.6. Please refer there for detailed information about how all these setpoints are used.

Setpoint Name	Value	Comment
SP Math Function Enabled	1	True
SP Math Input 1 Source	1	Received CAN J1939 Message
SP Math Input 1 Number	1	Received Message 1, Default Output 1 Command Input Data
SP Math Input 1 Minimum	0.500	
SP Math Input 1 Maximum	4.500	
SP Math Input 1 Scaler	0.75	
SP Math Input 2 Source	1	Received CAN J1939 Message
SP Math Input 2 Number	2	Received Message 2, Default Output 2 Command Input Data
SP Math Input 2 Minimum	0.500	
SP Math Input 2 Maximum	4.500	
SP Math Input 2 Scaler	0.25	
SP Math Function 1 (In1,In2)	9	+, Result = InA plus InB
SP Math Input 3 Source	0	Control Source Not Used
SP Math Input 3 Number		Not Applicable with this type of Control
SP Math Input 3 Minimum		No Control Source, Function Block Disabled
SP Math Input 3 Maximum		No Control Source, Function Block Disabled
SP Math Input 3 Scaler		No Control Source, Function Block Disabled
SP Math Function 2 (Func1,In3)		No Control Source, Function Block Disabled
SP Math Input 4 Source	0	Control Source Not Used
SP Math Input 4 Number		Not Applicable with this type of Control
SP Math Input 4 Minimum		No Control Source, Function Block Disabled
SP Math Input 4 Maximum		No Control Source, Function Block Disabled
SP Math Input 4 Scaler		No Control Source, Function Block Disabled
SP Math Function 3 (Func2,In4)		No Control Source, Function Block Disabled
SP Math Output Minimum Range	0.000	
SP Math Output Maximum Range	5.000	

Screen Capture of Example Math Function 1 Setpoints

Note: In the screen capture shown above, the “Math Function Enabled” has been changed from its default value in order to enable the function block. Other setpoints have also been changed from default values in order to illustrate how the block might look when functional, as per the example outlined in Section 1.6.

Name	Range	Default	Notes
Math Function Enabled	Drop List	0, False	True or False
Math Input X Source (X = 1 to 4)	Drop List	0, Control Source Not Used	See Table 17
Math Input X Number	Per Source	0	See Table 17
Math Input X Minimum	-10^6 to 10^6	0.0	Converts input to a percentage before use in the calculation.
Math Input X Maximum	-10^6 to 10^6	100.0	
Math Input X Scaler	-1.00 to 1.00	1.00	See Section 1.7
Math Output Minimum Range	-10^6 to 10^6	0.0	Converts calculation from a percentage value to the desired physical unit.
Math Output Maximum Range	-10^6 to 10^6	100.0	

4.8. CAN Transmit Setpoints

The CAN Transmit function block is defined in Section 1.9, with additional information in Section 3.3. Please refer there for detailed information about how all these setpoints are used.

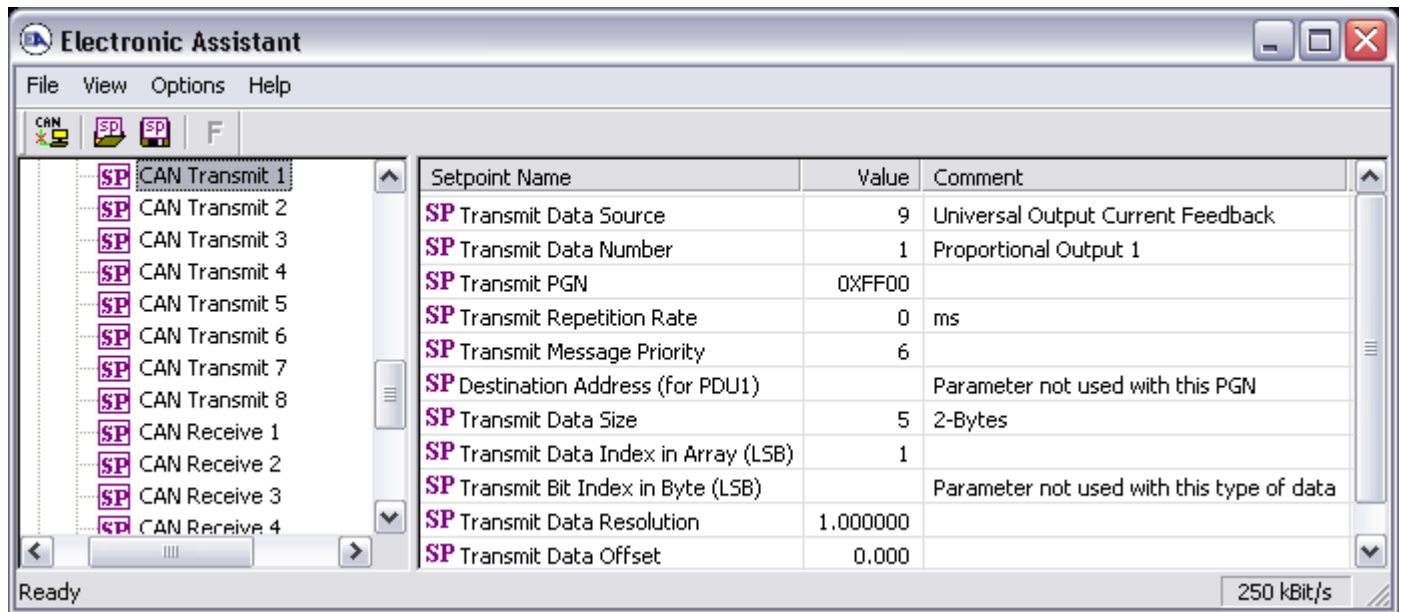

Screen Capture of Default CAN Transmit 1 Setpoints

Name	Range	Default	Notes
Transmit Data Source	Drop List	Different for each	See Table 14 for defaults
Transmit Data Number	Per Source	Different for each	See Table 14 for defaults
Transmit PGN	0 to 65535	65280 (0xFF00) Txd1 to 2	See Section 3.3 for defaults
Transmit Repetition Rate	0 to 60,000 ms	0	0ms disables transmit
Transmit Message Priority	0 to 7	6	Proprietary B Priority
Destination Address (for PDU1)	0 to 255	254 (0xFE, Null Address)	Not used by default
Transmit Data Size	Drop List	Different for each	0 = Not Used (disabled) 1 = 1-Bit 2 = 2-Bits 3 = 4-Bits 4 = 1-Byte 5 = 2-Bytes 6 = 4-Bytes See Section 3.3 for defaults
Transmit Data Index in Array (LSB)	1 to 9-DataSize	Different for each	See Section 3.3 for defaults
Transmit Bit Index in Byte (LSB)	1 to 9-BitSize	Different for each	Only used with Bit Data Types
Transmit Data Resolution	-10 ⁶ to 10 ⁶	Different for each	See Section 3.3 for defaults
Transmit Data Offset	-10 ⁴ to 10 ⁴	Different for each	See Section 3.3 for defaults



Recall that when multiple messages are sent on the same PGN, only the LOWEST Indexed channel's 'Repetition Rate' will be used. This means that even if a non-zero value is selected on a higher channel, but the lowest is still 0, no message will be sent.

4.9. CAN Receive Setpoints

The CAN Receive function block is defined in Section 1.10, with additional information in Section 3.4. Please refer there for detailed information about how all these setpoints are used.

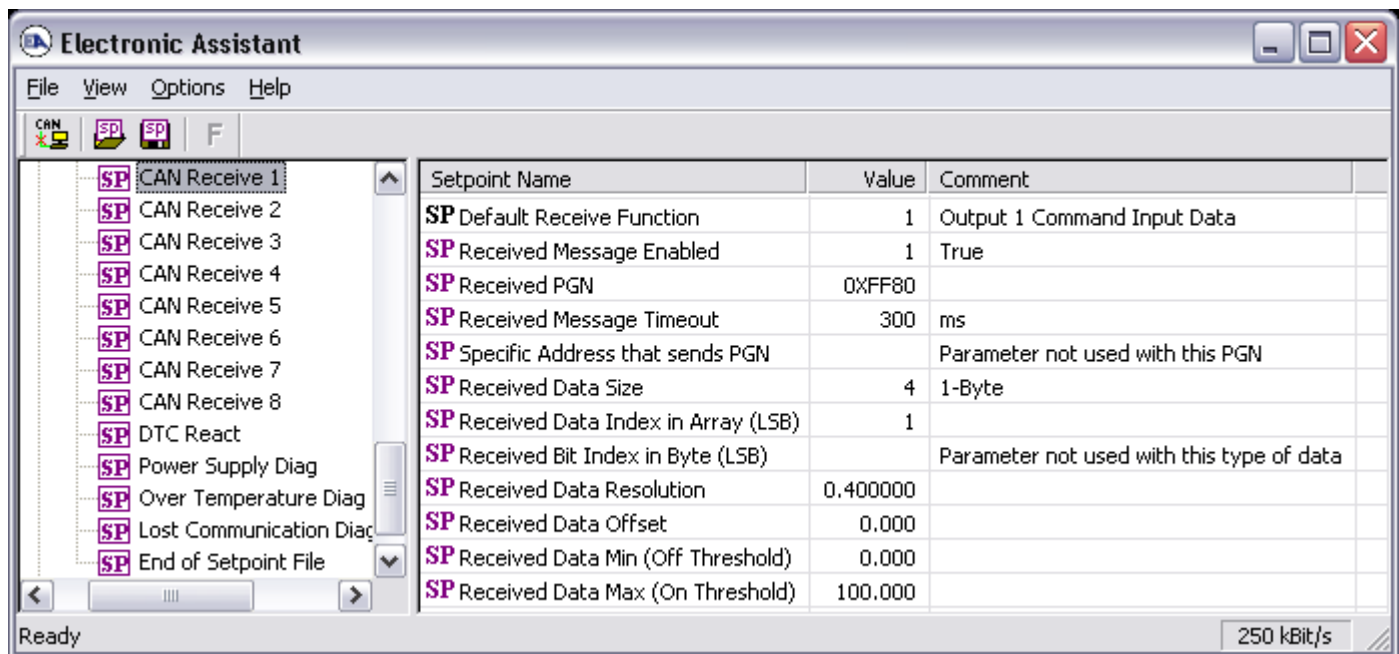

Screen Capture of Default CAN Receive 1 Setpoints

Note: If the “Received Message Enabled” setpoint is False all other setpoints read “No Control Source, Function Block Disabled”

Name	Range	Default	Notes
Default Receive Function	Drop List	Different for each	Read-Only Setpoint See Table 23 for defaults
Received Message Enabled	False or True	False	See note above
Received PGN	0 to 65535	65408 (0XFF80)	See Section 3.4 for defaults
Received Message Timeout	0 to 60,000 ms	300 ms	Expects all data at 100ms
Specific Address that sends PGN	0 to 255	254 (0xFE, Null Addr)	Not used by default
Receive Data Size	Drop List	Different for each	0 = Not Used (disabled) 1 = 1-Bit 2 = 2-Bits 3 = 4-Bits 4 = 1-Byte 5 = 2-Bytes 6 = 4-Bytes See Section 3.4 for defaults
Receive Data Index in Array (LSB)	1 to 9-DataSize	Different for each	See Section 3.4 for defaults
Receive Bit Index in Byte (LSB)	1 to 9-BitSize	Different for each	Only used with Bit Data Types
Receive Data Resolution	-10 ⁶ to 10 ⁶	Different for each	See Section 3.4 for defaults
Receive Data Offset	-10,000 to 10,000	Different for each	See Section 3.4 for defaults
Received Data Min (Off Threshold)	-10 ⁶ to Max	0.0	See Section 3.4 for defaults
Received Data Max (On Threshold)	-10 ⁴ to 10 ⁴	100.0	See Section 3.4 for defaults

4.10. DTC React Setpoints

The DTC React function block is defined in Section 1.8. Please refer there for detailed information about how all these setpoints are used.

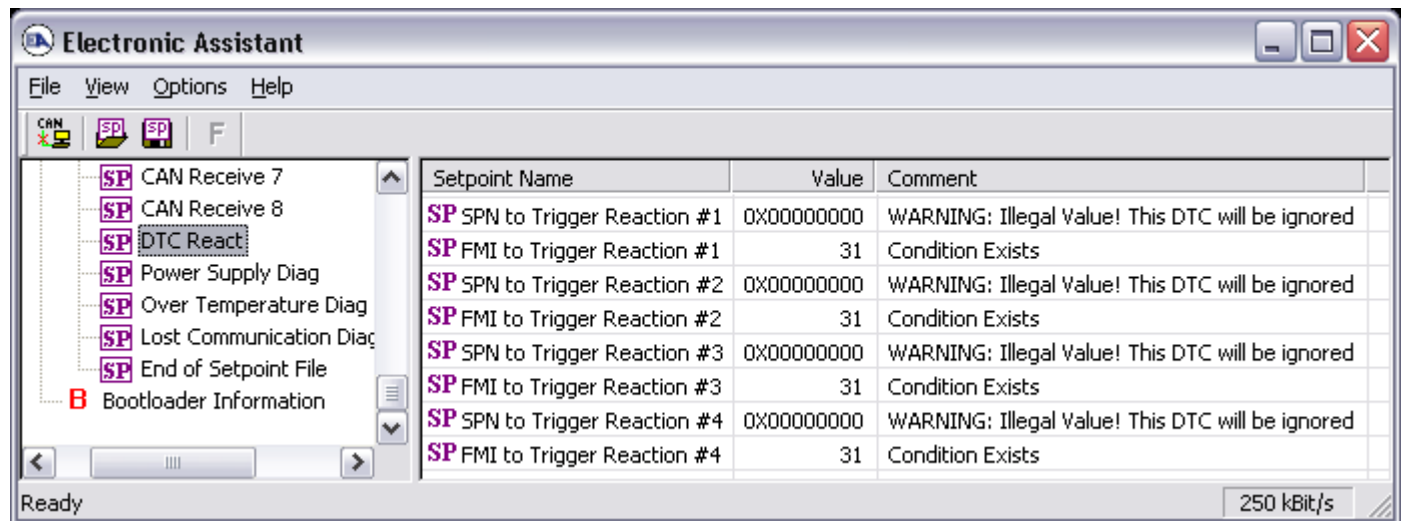

Screen Capture of Default DTC React Setpoints

Name	Range	Default	Notes
SPN to Trigger Reaction #X	0 to 524287	0	0 is an illegal value, and disables the DTC
FMI to Trigger Reaction #X	Drop List	31, Condition Exists	Supports all FMIs in the J1939 standard

Where X = 1 to 4

4.11. [Additional] Diagnostic Setpoints

Here, the [Additional] diagnostics are Power Supply, Over Temperature and Lost Communication. The Diagnostic function block is defined in Section 1.7. Please refer there for detailed information about how all these setpoints are used.

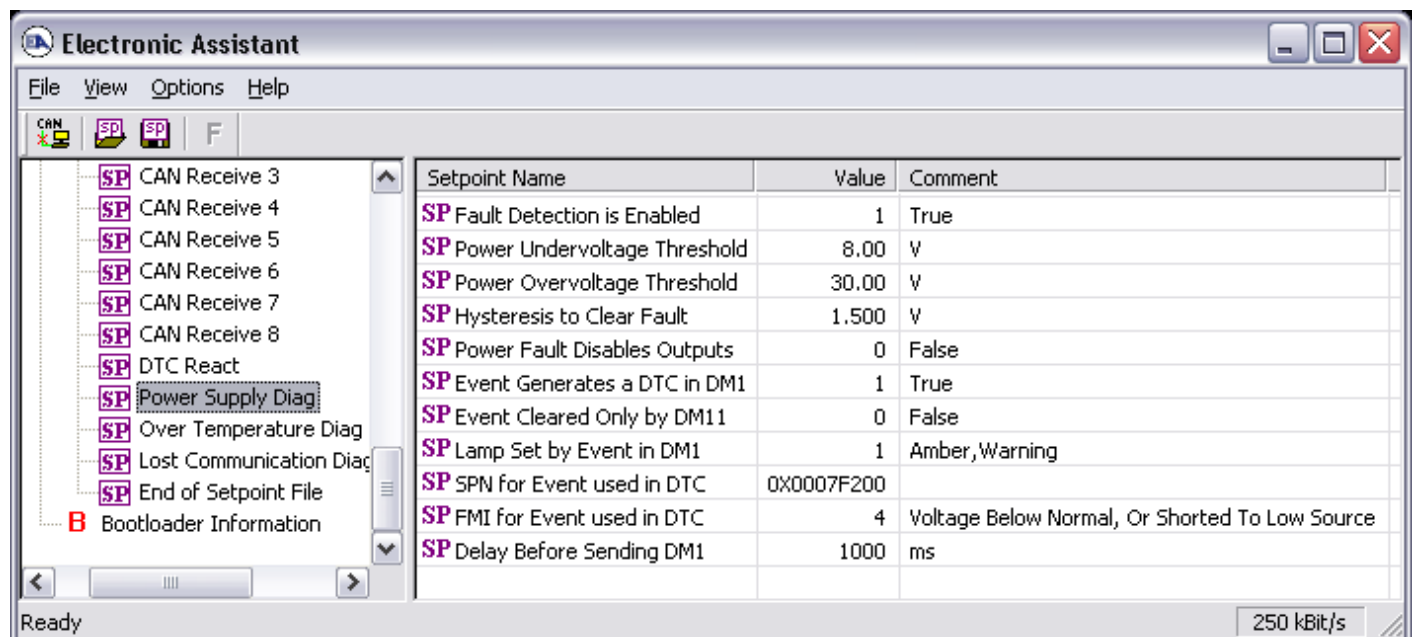

Screen Capture of Default Power Supply Diag Setpoints

Note: By default, the “Event Generates at DTC in DM1” is actually False, but it was changed to get the screen capture.

Name	Range	Default	Notes
Fault Detection is Enabled	False or True	True	See Section 1.7
Power Undervoltage Threshold *	7.5V to Over V	8.00 V	
Power Overvoltage Threshold *	Under V to 65V	30.00 V	
Over Temperature Shutdown **	0 to 125 DegC	125.00 Deg C	
Hysteresis to Clear Fault	0.01 to 250.00	1.50 V 5.00 DegC N/A	Power Temp Comm See Section 1.7
Power Fault Disables Outputs *	False or True	False	
Event Generates a DTC in DM1	False or True	False	See Section 1.7
Event Cleared Only by DM11	False or True	False	See Section 1.7
Lamp Set by Event in DM1	Drop List	1, Amber, Warning	See Section 1.7
SPN for Event used in DTC	1 to 524287	520704 (\$7F200) 520960 (\$7F300) 521216 (\$7F400)	Power Temp Comm See Section 1.7 and Section 3.3
FMI for Event used in DTC	Drop List	4, Voltage Below Normal 0, Data Above Normal–Most Sever 19, Received Data Error	Power Temp Comm See Section 1.7
Delay Before Sending DM1	0 to 60,000 ms	1000 ms	See Section 1.7

* Only used with Power Supply Diag group

** Only used with Over Temperature Diag group

5. REFLASHING OVER CAN WITH THE AXIOMATIC EA BOOTLOADER

The AX022310 can be upgraded with new application firmware using the **Bootloader Information** section. This section details the simple step-by-step instructions to upload new firmware provided by Axiomatic onto the unit via CAN, without requiring it to be disconnected from the J1939 network.

Note: To upgrade the firmware use Axiomatic Electronic Assistant V4.5.49.1 or higher.

1. When the Axiomatic EA first connects to the ECU, the **Bootloader Information** section will display the following information.

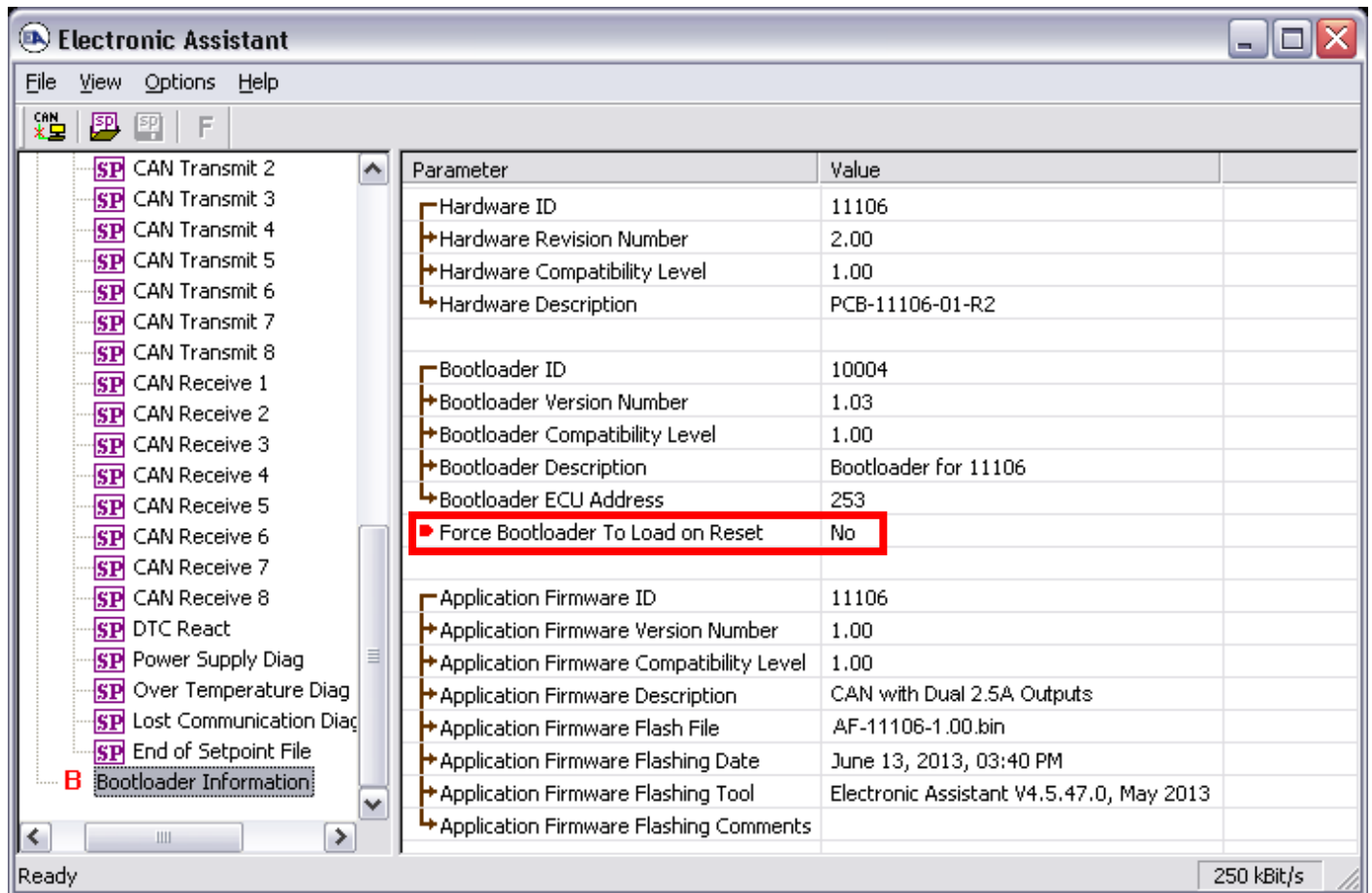

2. To use the bootloader to upgrade the firmware running on the ECU, change the variable **“Force Bootloader To Load on Reset”** to Yes.

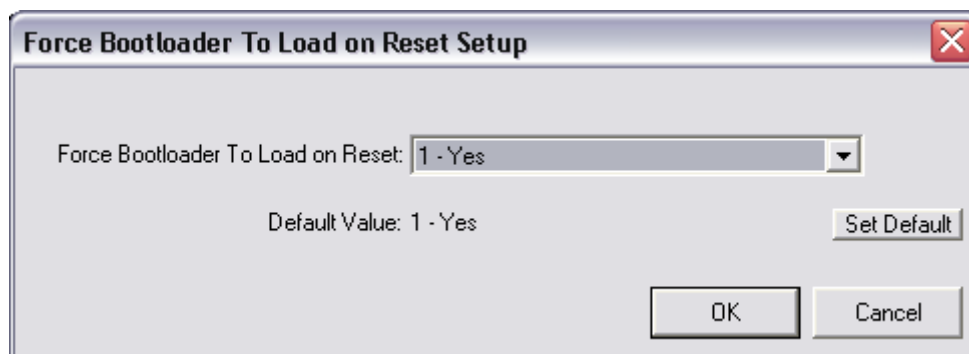

3. When the prompt box asks if you want to reset the ECU, select Yes.

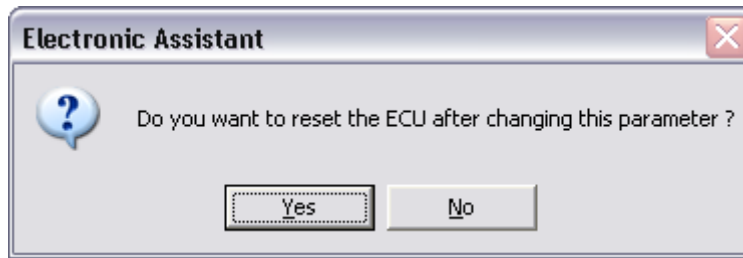

4. Upon reset, the ECU will no longer show up on the J1939 network as an AX022310 but rather as **J1939 Bootloader #1**.

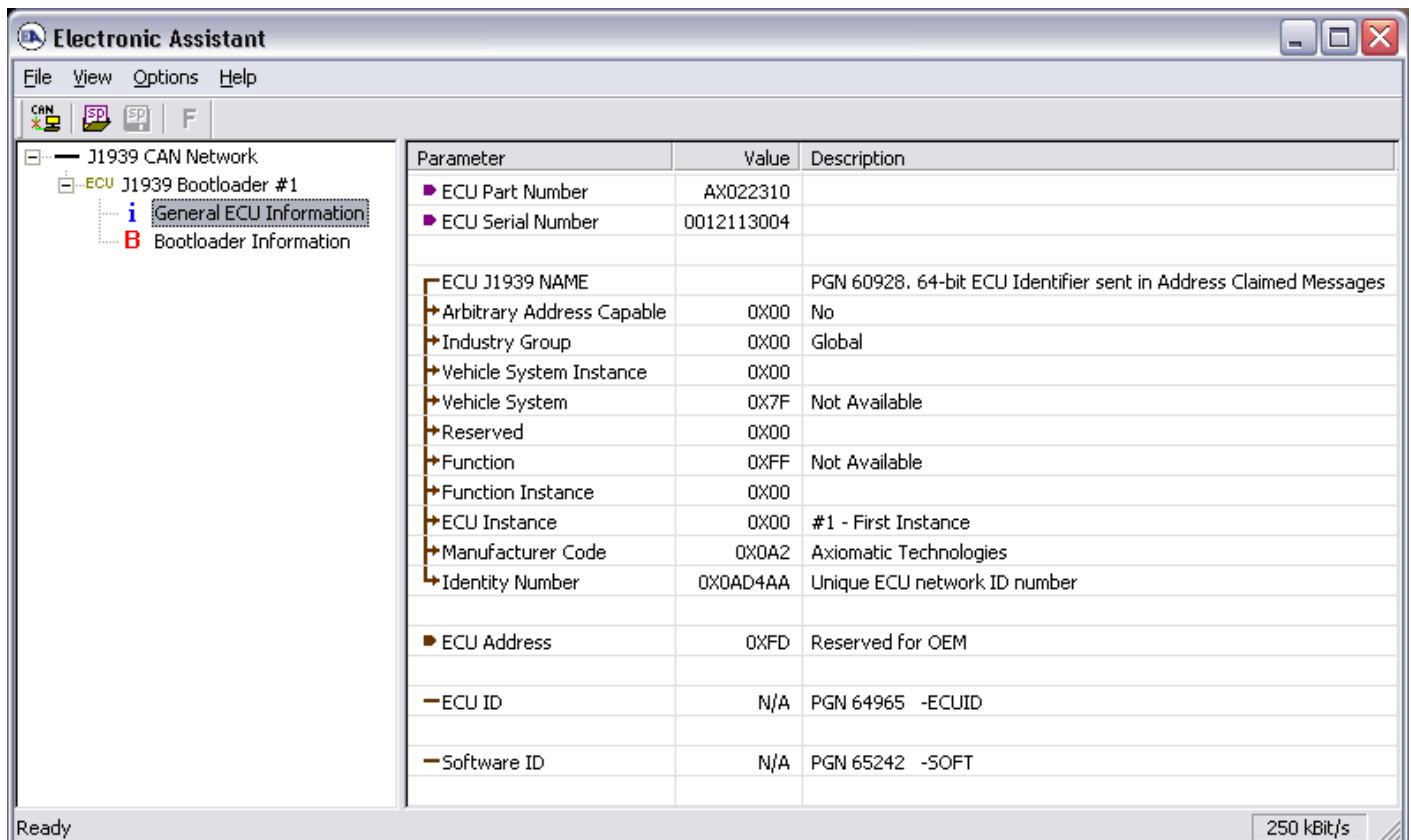
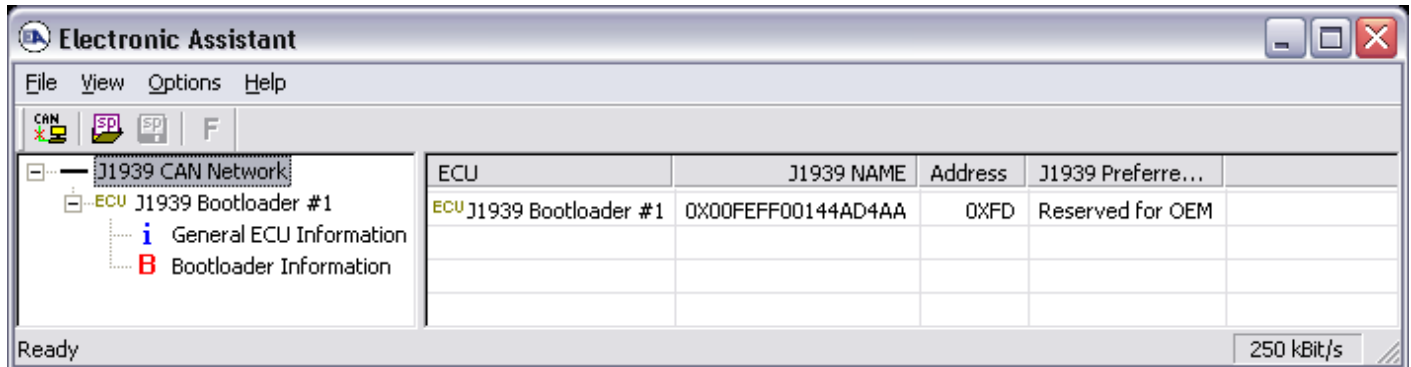

Note that the bootloader is NOT Arbitrary Address Capable. This means that if you want to have multiple bootloaders running simultaneously (not recommended) you would have to manually change the address for each one before activating the next, or there will be address conflicts, and

only one ECU would show up as the bootloader. Once the 'active' bootloader returns to regular functionality, the other ECU(s) would have to be power cycled to re-activate the bootloader feature.

5. When the **Bootloader Information** section is selected, the same information is shown as when it was running the AX022310 firmware, but in this case the **Flashing** feature has been enabled.

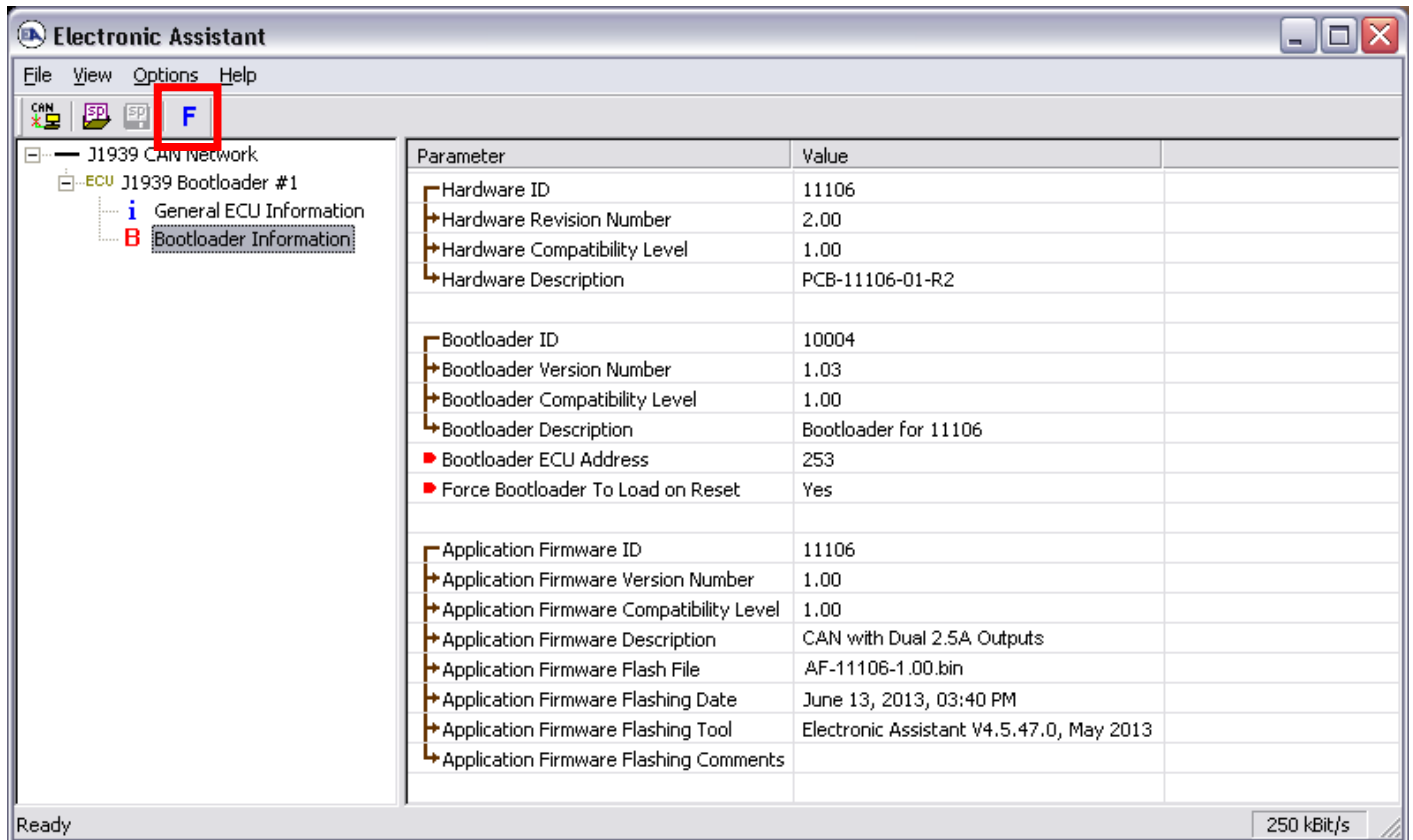

The screenshot shows the Electronic Assistant software window. The 'File View Options Help' menu bar is at the top. Below it, there are icons for CAN, SD, EP, and a highlighted 'F' (Flashing) button. The main window is divided into two panes. The left pane shows a tree view with 'J1939 CAN Network' expanded to 'ECU J1939 Bootloader #1', which is further expanded to 'Bootloader Information'. The right pane displays a table of parameters and their values.

Parameter	Value
Hardware ID	11106
Hardware Revision Number	2.00
Hardware Compatibility Level	1.00
Hardware Description	PCB-11106-01-R2
Bootloader ID	10004
Bootloader Version Number	1.03
Bootloader Compatibility Level	1.00
Bootloader Description	Bootloader for 11106
Bootloader ECU Address	253
Force Bootloader To Load on Reset	Yes
Application Firmware ID	11106
Application Firmware Version Number	1.00
Application Firmware Compatibility Level	1.00
Application Firmware Description	CAN with Dual 2.5A Outputs
Application Firmware Flash File	AF-11106-1.00.bin
Application Firmware Flashing Date	June 13, 2013, 03:40 PM
Application Firmware Flashing Tool	Electronic Assistant V4.5.47.0, May 2013
Application Firmware Flashing Comments	

Ready 250 kBit/s

6. Select the **Flashing** button and navigate to where you had saved the **AF-11106-x.yy.bin** file sent from Axiomatic. (Note: only binary (.bin) files can be flashed using the Axiomatic EA tool)

- Once the Flash Application Firmware window opens, you can enter comments such as “Firmware upgraded by [Name]” if you so desire. This is not required, and you can leave the field blank if you do not want to use it.

Note: You do not have to date-stamp or timestamp the file, as this is all done automatically by the Axiomatic EA tool when you upload the new firmware.

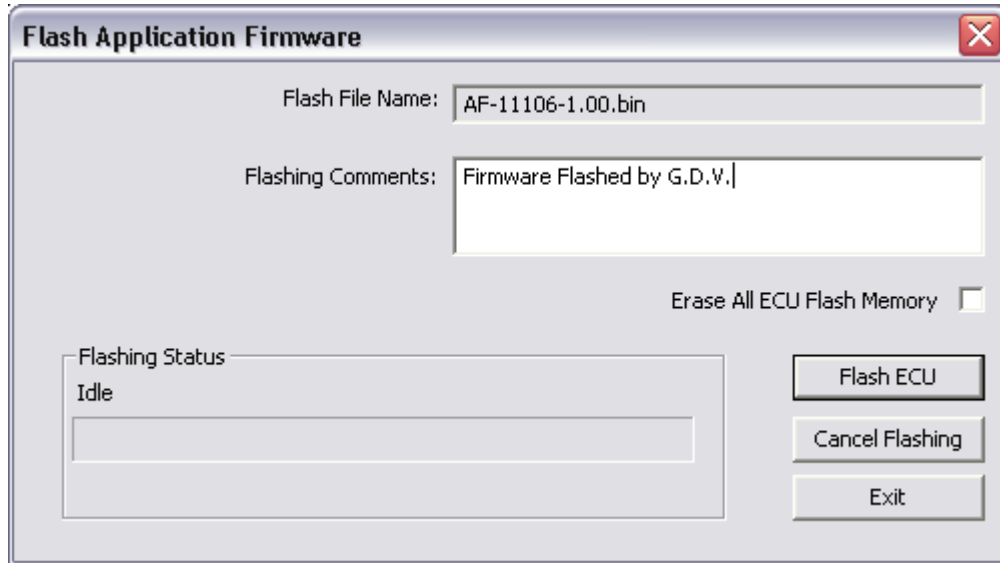



WARNING: Do not check the “Erase All ECU Flash Memory” box unless instructed to do so by your Axiomatic contact. Selecting this will erase ALL data stored in non-volatile flash, including the calibration done by Axiomatic during factory testing. It will also erase any configuration of the setpoints that might have been done to the ECU and reset all setpoints to their factory defaults. By leaving this box unchecked, none of the setpoints will be changed when the new firmware is uploaded.

- A progress bar will show how much of the firmware has been sent as the upload progresses. The more traffic there is on the J1939 network, the longer the upload process will take.

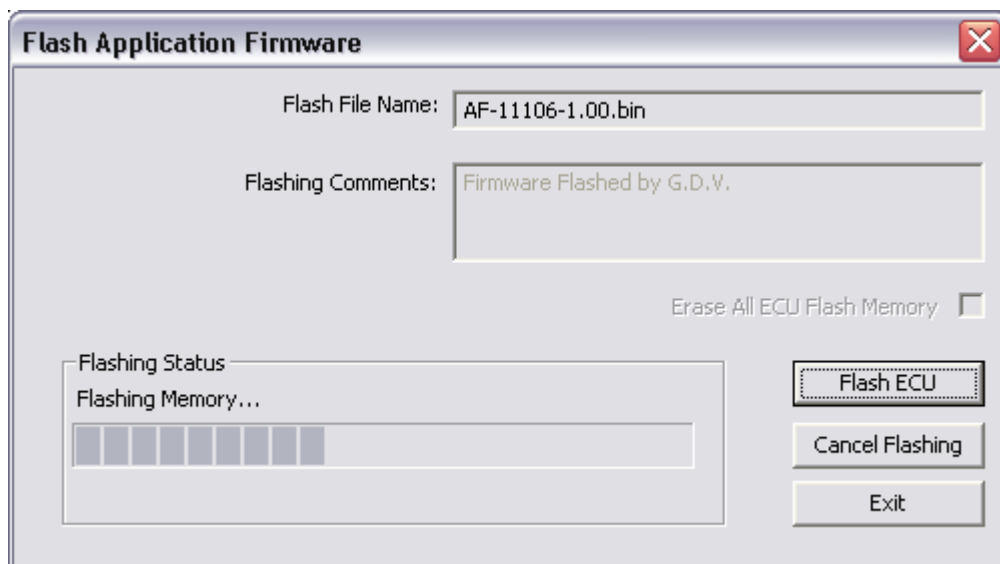

9. Once the firmware has finished uploading, a message will popup indicating the successful operation. If you select to reset the ECU, the new version of the AX022310 application will start running, and the ECU will be identified as such by the Axiomatic EA. Otherwise, the next time the ECU is power-cycled, the AX022310 application will run rather than the bootloader function.

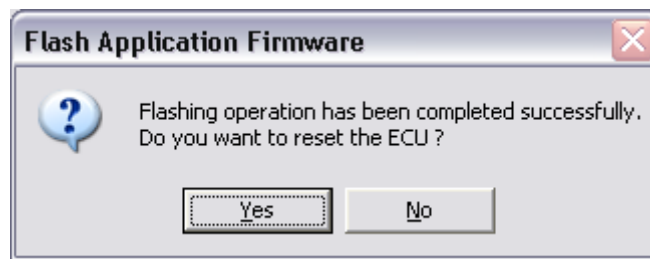

Note: If at any time during the upload the process is interrupted, the data is corrupted (bad checksum) or for any other reason the new firmware is not correct, i.e. bootloader detects that the file loaded was not designed to run on the hardware platform, the bad or corrupted application will not run. Rather, when the ECU is reset or power-cycled the **J1939 Bootloader** will continue to be the default application until valid firmware has been successfully uploaded into the unit.

6. Diagnostic Trouble Codes Table

J1939/73 DM1/2		Description	Detection conditions	Associated Setpoint Group	Restricted Function
SPN ¹ /FMI	Lamp ¹				
520448-05	Amber	Output 1 Current Open Circuit	Output 1 Current FB error > 100mA (when ON)	Output 1 Drive	None
520448-06	Amber	Output 1 Current Short Circuit (Hardware)	Output 1 Current FB > ~4500mA	Output 1 Drive	Out 1 Off
520449-05	Amber	Output 2 Current Open Circuit	Output 2 Current FB error > 100mA (when ON)	Output 2 Drive	None
520449-06	Amber	Output 2 Current Short Circuit (Hardware)	Output 2 Current FB > ~4500mA	Output 2 Drive	Out 2 Off
520704-04	Amber	Power Supply Under Voltage	Measured Power Supply < Power Undervoltage Threshold	Power Supply Diag	Outs Off
520704-03	Amber	Power Supply Over Voltage	Measured Power Supply > Power Overvoltage Threshold	Power Supply Diag	Outs Off
520960-00	Amber	Processor Over Temperature	Did not receive an expected CAN message within timeout period	Over Temperature Diag	Outs Off
521216-19	Amber	Lost Communication	Did not receive an expected CAN message within timeout period	CAN Receive X	Out Off

Note 1: SPN, FMI and Lamp Type are user configurable parameters for all DTC. Default values are shown in this table

Note 2: All diagnostic trouble code (DTC) can be disabled at any time by setting the "XXX Fault Generates DTCs" to FALSE.

If this setpoint for all diagnostics are FALSE, the DM1 message will not be sent every 1 second (i.e. in a standalone 2oPi mode where no CAN is connected)

7. TECHNICAL SPECIFICATIONS

Input Specifications

Power Supply Input - Nominal	12V, 24V or 32VDC nominal 9...36 VDC
Supply Current	16.41 mA at 12 V Typical, 11.74 mA at 24 V Typical
Reverse Polarity Protection	Provided
Surge Protection	Provided (up to 38V)
Under-voltage Protection	Provided (software, hardware shutdown at 7.5V)
Over-voltage Protection	Provided (software)

Output Specifications

<p>Universal Outputs</p>	<p>Two independent software controlled outputs selectable as: Proportional Current; Hotshot Digital; PWM Duty Cycle; Proportional Voltage; or On/Off Digital types</p> <p>Half-bridge outputs, current sensing, grounded load. High side sourcing up to 2.5A</p> <p>Current Outputs: 1mA resolution, accuracy +/- 2% error Software controlled PID current Fully configurable dither from 50 to 400Hz. High frequency drive at 25kHz <i>Note: Both Outputs use the same dither and drive frequencies</i></p> <p>Voltage Outputs: 0.1V resolution, accuracy +/- 3% error Average output based on unit power supply High frequency drive at 25kHz</p> <p>PWM Outputs: 0.1% resolution, accuracy +/- 1% error Output Frequency: 1Hz to 25kHz Configurable frequency ONLY if no current output types are used, otherwise default 25kHz is used</p> <p>Digital On/Off: Load at supply voltage must not draw more than 2.5A. Refer to Figure 26 - De-rating Curve.</p> <div data-bbox="1365 812 1984 1169"> <table border="1"> <caption>Data points for Figure 26 - De-rating Curve</caption> <thead> <tr> <th>Output Current [mA]</th> <th>32Vin Ambient Temp [°C]</th> <th>24Vin Ambient Temp [°C]</th> <th>12Vin Ambient Temp [°C]</th> <th>9Vin Ambient Temp [°C]</th> </tr> </thead> <tbody> <tr> <td>0</td> <td>85</td> <td>85</td> <td>85</td> <td>85</td> </tr> <tr> <td>500</td> <td>85</td> <td>85</td> <td>85</td> <td>85</td> </tr> <tr> <td>1000</td> <td>85</td> <td>85</td> <td>85</td> <td>85</td> </tr> <tr> <td>1500</td> <td>85</td> <td>85</td> <td>85</td> <td>85</td> </tr> <tr> <td>2000</td> <td>85</td> <td>85</td> <td>85</td> <td>85</td> </tr> <tr> <td>2500</td> <td>78</td> <td>75</td> <td>70</td> <td>58</td> </tr> </tbody> </table> </div> <p>Figure 26 – De-rating Curve</p>	Output Current [mA]	32Vin Ambient Temp [°C]	24Vin Ambient Temp [°C]	12Vin Ambient Temp [°C]	9Vin Ambient Temp [°C]	0	85	85	85	85	500	85	85	85	85	1000	85	85	85	85	1500	85	85	85	85	2000	85	85	85	85	2500	78	75	70	58
Output Current [mA]	32Vin Ambient Temp [°C]	24Vin Ambient Temp [°C]	12Vin Ambient Temp [°C]	9Vin Ambient Temp [°C]																																
0	85	85	85	85																																
500	85	85	85	85																																
1000	85	85	85	85																																
1500	85	85	85	85																																
2000	85	85	85	85																																
2500	78	75	70	58																																
<p>Protection</p>	<p>Fully protected against short circuit to ground or +Vcc Grounded short circuit protection will engage at 4.5A +/- 0.5A Unit will fail safe in the case of a short-circuit condition, and is self-recovering when the short is removed.</p>																																			
<p>Power GND Reference</p>	<p>One Provided</p>																																			

General Specifications

Microprocessor	32-bit, 128 KByte flash program memory	
Diagnostics	Each input and output channel can be configured to send diagnostic messages to the J1939 CAN network if the I/O goes out of range. Diagnostic data is stored in a non-volatile log. Refer to Section 1.7 for details	<p>Set up of SAE J1939 Controller on a CAN Network:</p>
Additional Fault Feedback	There are several types of faults that the controller will detect and provide a response: unit power supply undervoltage and overvoltage, microprocessor over temperature and lost communication. They can be sent to the J1939 CAN bus.	
CAN User Interface	<p>Compliant to SAE CAN J1939 Standard. 250kbit/s, 500kbit/s, 667kbit/s, 1Mbit/s. Automatic Baud Rate Detection</p> <p>Configurable via CAN using Electronic Assistant for <i>Windows</i> operating systems. It comes with a royalty-free license for use.</p> <p>The Axiomatic Electronic Assistant requires an USB-CAN converter to link the device's CAN port to a <i>Windows</i>-based PC for initial configuration. An Axiomatic USB-CAN Converter AX070501 is available.</p> <p>Order the Axiomatic EA and USB-CAN as a KIT (P/Ns: AX070502 or AX070506K), which includes all interconnecting cables.</p>	
Reflashing over CAN	Yes, per J1939 standard using the Axiomatic Electronic Assistant	
Electrical Connections	Refer to Section 2. Wires should be of the appropriate gauge to meet requirements of applicable electrical codes and suit the specifications of the connector(s).	
Packaging and Dimensions	<p>Molded Enclosure, integral connectors</p> <p>Polyester, 15% glass</p> <p>Silicone seals</p> <p>3.037 x 1.44 x 1.53 inches (77.1 x 36.6 x 38.8 mm)</p> <p>L x W x H including integral connectors</p> <p>Refer to Figure 25 for dimensions</p>	
Environmental Protection	IP67	
Vibration	<p>Random Vibration for vibration isolated cab mount components</p> <p>16 hours/axis, 4.41 - 6.79 Grms, 5 Hz – 2000 Hz, Modified Kurtosis 9.3</p> <p>Parts of SAE J1445, MIL-STD-202, IEC 60068-2-64</p>	
Temperature Rating	<p>Operating: -40 to 85°C (-40 to 185°F)</p> <p>Storage: -50 to 105°C (-58 to 221°F)</p>	
Weight	0.15 lbs. (0.068 kg)	

Note:

Technical Specifications are indicative and subject to change. Actual performance will vary depending on the application and operating conditions. Users should satisfy themselves that the product is suitable for use in the intended application. All our products carry a limited warranty against defects in material and workmanship. Please refer to our Warranty, Application Approvals/Limitations and Return Materials Process as described on <https://www.axiomatic.com/service/>.

8. VERSION HISTORY

User Manual Version	Firmware Version	Date	Author	Modifications
2C	--	August 9, 2023	Kiril Mojsov	Performed Legacy Updates
2B	2.00	November 10, 2022	Weixin Kong	Added automatic baud rate detection.
--	--	August 16, 2016	Amanda Wilkins	Corrected CAN bus pin out.
--	--	January 23, 2015	Amanda Wilkins	Added vibration rating
1A	1.xx	August 19, 2013	Amanda Wilkins	- Added Figure 26 – De-rating Curve
1A	1.xx	June 28 th , 2013	Gustavo Del Valle	- Modified information on Packaging and Dimensions - Modified power supply range to 9-36V
1	1.xx	June 13 th , 2013	Gustavo Del Valle	Initial Draft

OUR PRODUCTS

AC/DC Power Supplies
Actuator Controls/Interfaces
Automotive Ethernet Interfaces
Battery Chargers
CAN Controls, Routers, Repeaters
CAN/WiFi, CAN/Bluetooth, Routers
Current/Voltage/PWM Converters
DC/DC Power Converters
Engine Temperature Scanners
Ethernet/CAN Converters,
Gateways, Switches
Fan Drive Controllers
Gateways, CAN/Modbus, RS-232
Gyroscopes, Inclinometers
Hydraulic Valve Controllers
Inclinometers, Triaxial
I/O Controls
LVDT Signal Converters
Machine Controls
Modbus, RS-422, RS-485 Controls
Motor Controls, Inverters
Power Supplies, DC/DC, AC/DC
PWM Signal Converters/Isolators
Resolver Signal Conditioners
Service Tools
Signal Conditioners, Converters
Strain Gauge CAN Controls
Surge Suppressors

OUR COMPANY

Axiomatic provides electronic machine control components to the off-highway, commercial vehicle, electric vehicle, power generator set, material handling, renewable energy and industrial OEM markets. ***We innovate with engineered and off-the-shelf machine controls that add value for our customers.***

QUALITY DESIGN AND MANUFACTURING

We have an ISO9001:2015 registered design/manufacturing facility in Canada.

WARRANTY, APPLICATION APPROVALS/LIMITATIONS

Axiomatic Technologies Corporation reserves the right to make corrections, modifications, enhancements, improvements, and other changes to its products and services at any time and to discontinue any product or service without notice. Customers should obtain the latest relevant information before placing orders and should verify that such information is current and complete. Users should satisfy themselves that the product is suitable for use in the intended application. All our products carry a limited warranty against defects in material and workmanship. Please refer to our Warranty, Application Approvals/Limitations and Return Materials Process at <https://www.axiomatic.com/service/>.

COMPLIANCE

Product compliance details can be found in the product literature and/or on axiomatic.com. Any inquiries should be sent to sales@axiomatic.com.

SAFE USE

All products should be serviced by Axiomatic. Do not open the product and perform the service yourself.



This product can expose you to chemicals which are known in the State of California, USA to cause cancer and reproductive harm. For more information go to www.P65Warnings.ca.gov.

SERVICE

All products to be returned to Axiomatic require a Return Materials Authorization Number (RMA#) from sales@axiomatic.com. Please provide the following information when requesting an RMA number:

- Serial number, part number
- Runtime hours, description of problem
- Wiring set up diagram, application and other comments as needed

DISPOSAL

Axiomatic products are electronic waste. Please follow your local environmental waste and recycling laws, regulations and policies for safe disposal or recycling of electronic waste.

CONTACTS

Axiomatic Technologies Corporation
1445 Courtneypark Drive E.
Mississauga, ON
CANADA L5T 2E3
TEL: +1 905 602 9270
FAX: +1 905 602 9279
www.axiomatic.com
sales@axiomatic.com

Axiomatic Technologies Oy
Höytämöntie 6
33880 Lempäälä
FINLAND
TEL: +358 103 375 750
www.axiomatic.com
salesfinland@axiomatic.com