



USER MANUAL UMAX021301

**6 On/Off Valve Controller,
with CANopen®**

USER MANUAL

P/N: AX021301

VERSION HISTORY

Version	Date	Author	Modifications
1.0.0	July 14, 2011	Hassan Sharifian	Initial Draft
-	July 20, 2011	Amanda Wilkins	Marketing Review
1.0.1	August 8, 2023	Kiril Mojsov	Legacy Updates

ACRONYMS

CAN	Controller Area Network
CANopen®	CANopen® is a registered community trademark of CAN in Automation e.V.
CAN-ID	CAN 11-bit Identifier
COB	Communication Object
CTRL	Control
DI	Digital Input
DO	Digital Output (Relay)
EDS	Electronic Data Sheet
EMCY	Emergency
LSB	Least Significant Byte (or Bit)
LSS	Layer Settling Service
MSB	Most Significant Byte (or Bit)
NMT	Network Management
RO	Read Only Object
RPDO	Received Process Data Object
RW	Read/Write Object
SDO	Service Data Object
TPDO	Transmitted Process Data Object
WO	Write Only Object

REFERENCES

[DS-301]	CiA DS-301 V4.1 – CANopen® Application Layer and Communication Profile. CAN in Automation 2005
[DS-305]	CiA DS-305 V2.0 – Layer Setting Service (LSS) and Protocols. CAN in Automation 2006
[DS-401]	CiA DS-401 V3.0 – CANopen® device profile for generic I/O modules. CAN in Automation 2008

These documents are available from the CAN in Automation e.V. website: <http://www.can-cia.org/>.

TABLE OF CONTENTS

1. OVERVIEW OF CONTROLLER	5
1.1. Description of 6 On/Off Valve Controller	5
1.2. Description of Inputs	6
1.2.1. General Input Functionality	6
1.2.2. Digital Input Function Block.....	9
1.3. Description of Outputs.....	11
1.3.1. General Output Functionality	11
1.3.2. Digital Output Function Block	12
1.4. Miscellaneous Function Block	13
2. INSTALLATION INSTRUCTIONS	14
2.1. Dimensions and Pinout.....	14
2.2. Installation Instructions.....	15
3. CANOPEN® OBJECT DICTIONARY	17
3.1. NODE ID and BAUDRATE	17
3.1.1. LSS Protocol to Update	17
3.1.1.1. Setting Node-ID	17
3.1.1.2. Setting Baudrate	18
3.2. COMMUNICATION OBJECTS (DS-301 and DS-401)	21
3.2.1. Object 1000h: Device Type	22
3.2.2. Object 1001h: Error Register	23
3.2.3. Object 1003h: Pre-Defined Error Field.....	23
3.2.4. Object 100Ch and 100Dh: Guard Time and Lifetime Factor	25
3.2.5. Object 1010h: Store Parameters.....	25
3.2.6. Object 1011h: Restore Parameters	27
3.2.7. Object 1016h: Consumer Heartbeat Time.....	28
3.2.8. Object 1017h: Producer Heartbeat Time	29
3.2.9. Object 1018h: Identity Object	29
3.2.10. Object 1020h: Verify Configuration.....	30
3.2.11. Object 1029h: Error Behaviour	31
3.2.12. RPDO Behaviour.....	32
3.2.13. TPDO Behaviour.....	35
3.3. APPLICATION OBJECTS (DS-401)	37
3.3.1. Object 6000h: DI Read Input 8-bit.....	37
3.3.2. Object 6002h: DI Polarity 8-bit.....	38
3.3.3. Object 6200h: DO Write Output 8-bit.....	38
3.3.4. Object 6202h: DO Polarity 8-bit.....	39
3.3.5. Object 6206h: DO Error Mode 8-bit	39
3.3.6. Object 6207h: DO Error Value 8-bit	40
3.3.7. Object 6220h: DO Write Output Bit.....	41
3.3.8. Object 6401h: Read Analog Input.....	41
3.3.9. Object 6431h: Analog Input Offset	42
3.3.10. Object 6432h: Analog Input Pre-scale.....	42
3.4. MANUFACTURER OBJECTS	44
3.4.1. Object 2000h: DI Pull Up Pull Down.....	44
3.4.2. Object 2002h: DI Latched 8-bit	45
3.4.3. Object 2200h: DO Read Output 8-bit	45

3.4.4.	Object 2210h: DO Control Source	46
3.4.5.	Object 2212h: DO Output Type	47
3.4.6.	Object 2230h: DO Output Frequency	47
3.4.7.	Object 2231h: DO Output Duty Cycle.....	48
3.4.8.	Object 2240h: DO Output Startup Delay	48
3.4.9.	Object 2241h: DO Output ON Time.....	49
3.4.10.	Object 2242h: DO Output Timer Repeat	49
3.4.11.	Object 2243h: DO Output OFF Time	50
3.4.12.	Object 2250h: DO Output Current Feedback	50
3.4.13.	Object 2400h: AI Input Type	51
3.4.14.	Object 2410h: AI Input Range	52
3.4.15.	Object 2421h: AI Maximum	54
3.4.16.	Object 2430h: AI Decimal Digits.....	54
3.4.17.	Object 2440h: AI Filter Type	55
3.4.18.	Object 2441h: AI Filter Constant	56
3.4.19.	Object 2600h: ADC Filter Frequency	56
3.4.20.	Object 2601h: Power Supply Under Voltage	57
3.4.21.	Object 2602h: Power Supply Over Voltage.....	57
3.4.22.	Object 2651h: Error Reaction Delay.....	57
3.4.23.	Object 2652h: Error Reaction Delay.....	58
3.4.24.	Object 5020h: Power Supply Over Voltage.....	59
3.4.25.	Object 5555h: Start in Operational Mode	60
	APPENDIX A – Technical Specifications.....	1

List of Figures

Figure 1	Analog Input Objects	6
Figure 2	Analog Input Read as Digital	7
Figure 3	Digital Input Objects	9
Figure 4	Digital Input Debouncing.....	9
Figure 5	Digital Input Latched Logic	10
Figure 6	Digital Output Objects	12

List of Tables

Table 1	List of Input Types.....	6
Table 2	List of Input Ranges.....	7
Table 3	ADC Filter Frequency Options	8
Table 4	AI Filter Type Options	8
Table 5	Digital Input Bitmap	9
Table 6	DI Pullup/Down Options	10
Table 7	List of Output Types.....	11
Table 8	Digital Output Bitmap.....	12
Table 9	LSS Baudrate Indexes	19
Table 10	Pre-Defined Error Field Codes	24

1. OVERVIEW OF CONTROLLER

1.1. Description of 6 On/Off Valve Controller

The 6 On/Off Valve Controller electronic control unit (ECU) is a device intended to provide control of up to six digital outputs over a CANopen® network. In addition to the outputs, however, the ECU also has two 'analog' and three 'frequency' inputs (see below). Each can be configured to measure the input value, and send the data over the CAN network using a TPDO. In addition, any output on the ECU could be configured to use any of the on board inputs as a control signal, instead of taking the control information from the CAN bus.

The AX021301 is a versatile controller compliant with the CiA standard DS-401. It supports many objects from that device profile as well as some manufacturer objects to provide expanded functionality. All objects are user configurable using standard commercially available tools that can interact with a CANopen® Object Dictionary via an .EDS file.

Depending on how they set it up, the user can easily switch from having the output respond to CAN commands; using the discrete inputs to drive some or all of the outputs; or having them go to an individually preset state in error mode.

1.2. Description of Inputs

1.2.1. General Input Functionality

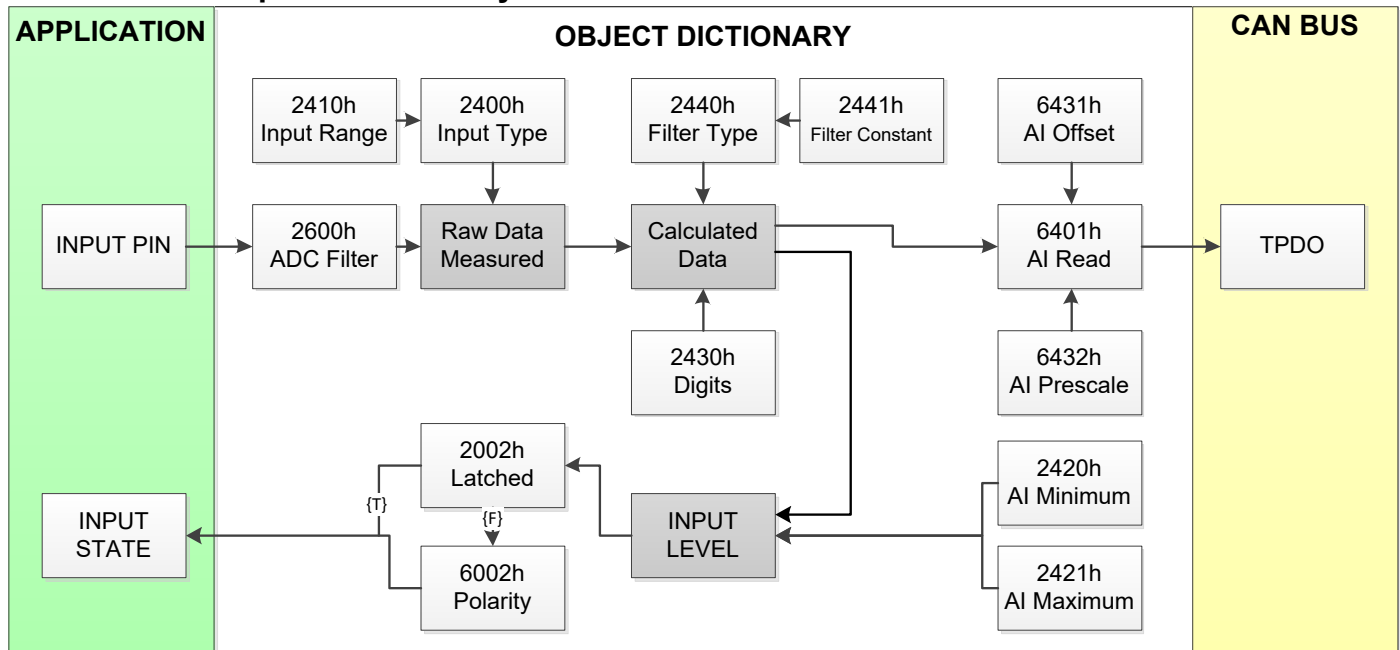

Figure 1 Analog Input Objects

Each input can be configured for any one of the following options, unless noted otherwise. The properties and behavior of the input in each mode is described below. Object **2400h: AI Input Type** is used to change the input type. Table 1 shows the list of inputs types available on the AX021301.

Value	Input Type
0	Voltage (0-5V)
1	Current (0-20mA or 4-20mA)
2	Digital (ON-OFF)
3	PWM
4	Frequency

Table 1 List of Input Types

It should be noted that since inputs 3, 4 and 5 are only digital inputs; their input type cannot be selected as a Voltage or Current. For inputs 1 and 2, all types are available.

For more versatility and resolution, some of the inputs have specific ranges that they could operate in. These ranges can be selected in object **2410h Input Range**. Table 2 shows the list of input ranges available.

Input Type	Value	Range
Voltage	0	0-5V
Current	0	0-20mA
	1	4-20mA
Digital	0	ON-OFF
Frequency	0	0.5Hz to 50Hz
	1	10Hz to 1KHz
	2	100Hz to 10KHz
PWM	0	10Hz to 1KHz
	1	100Hz to 10KHz

Table 2 List of Input Ranges

Objects **2420h Input Minimum** and **2421h Input Maximum** can be used to set the minimum and maximum values of the inputs. One purpose of these objects is that they are used to control the output proportionally to the input only when they output type is set to PWM. When this is the case, an input measure value of Input Minimum will represent 0% duty cycle on the output and an input measure of Input Maximum will represent 100% duty cycle on the output.

These objects are also used for determining the state of a digital (ON-OFF) input type for inputs 1 and 2. A digital input type for these two inputs still needs a voltage connected to the input. When this voltage is above the value set in object 2421h, then the input state is considered as an ON. Similarly, if the input voltage is changed to a value less than that set in object 2420h, then the input state is considered as an OFF. Figure 2 shows visually shows this concept.

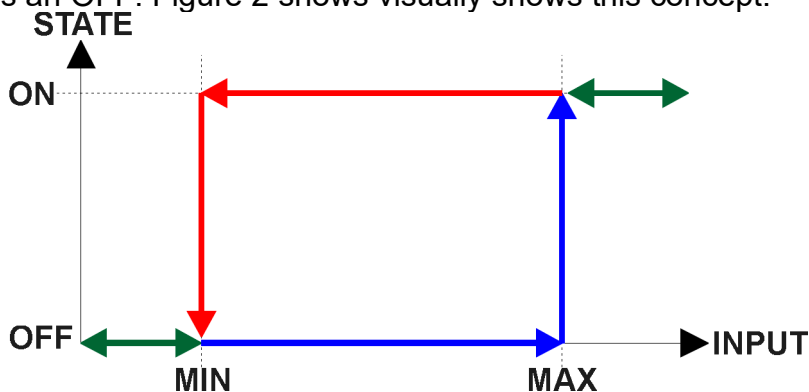

Figure 2 Analog Input Read as Digital

The measured values of analog inputs 1 and 2 are stored in object **6401h AI Read Input**. This object is mapped to TPDO2 by default. The value of this object can be scaled by object **6431h AI Analog Input Offset** and object **6432h Analog Input Pre-scale**. It is the user's responsibility to scale the measured input such that it does not exceed the data type limit.

The analog signals on inputs 1 and 2 are filtered for noise rejection and object **2600h ADC Filter Frequency** is used to set the type of filter. The ADC will filter as per Table 3, and by default it is set for 50Hz noise rejection by default.

Value	Meaning
0	Input Filter Off
1	Filter 50Hz
2	Filter 60Hz
3	Filter 50Hz and 60Hz

Table 3 ADC Filter Frequency Options

These analog inputs can be further filtered once the raw data has been measured. Object **2440h AI Filter Type** determines what kind of filter is used per Table 4. By default, additional software filtering is disabled.

Value	Meaning
0	No Filter
1	Moving Average
2	Repeating Average

Table 4 AI Filter Type Options

Object **2441h AI Filter Constant** is used with both types of filters as per the formulas below:

Calculation with no filter:

$$\text{Value} = \text{Input}$$

The data is simply a 'snapshot' of the latest value measured by the ADC or timer.

Calculation with the moving average filter:

$$\text{Value}_N = \text{Value}_{N-1} + \frac{(\text{Input} - \text{Value}_{N-1})}{\text{FilterConstant}}$$

This filter is called every 1ms. The value FilterConstant stored in object 2441h is 10 by default.

Calculation with the repeating average filter:

$$\text{Value} = \frac{\sum \text{Input}_N}{N}$$

At every reading of the input value, it is added to the sum. At every Nth read, the sum is divided by N, and the result is the new input value. The value and counter will be set to zero for the next read. The value of N is stored in object 2441h, and is 10 by default. This filter is called every 1ms.

1.2.2. Digital Input Function Block

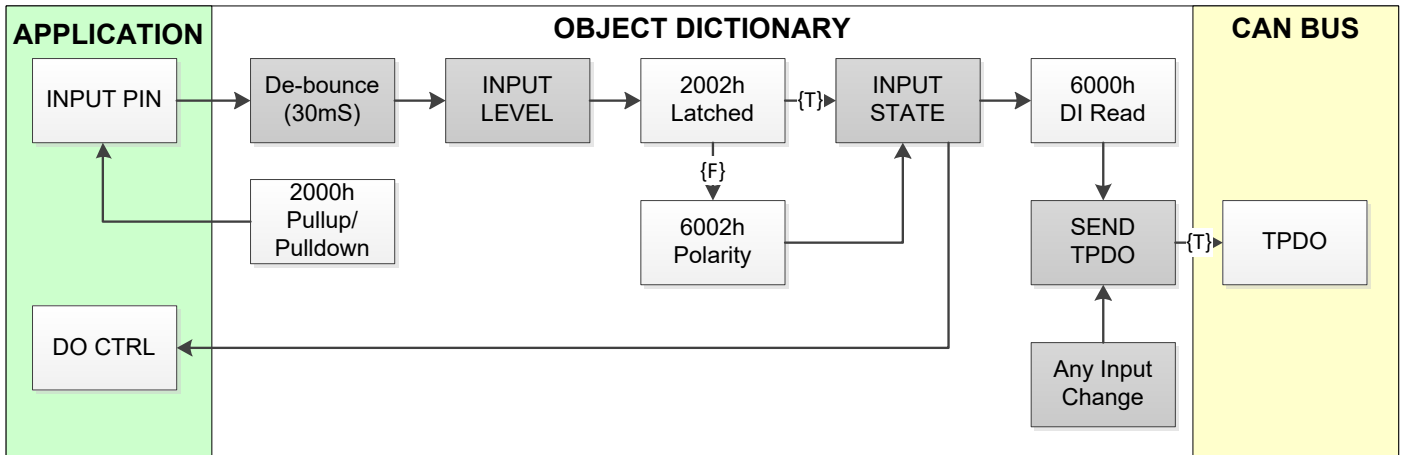

Figure 3 Digital Input Objects

For the digital inputs (DI), all associated objects from 6000h to 6207h and object 2002h are an 8-bit type. The table below shows the relationship between each bit and the corresponding input. This allows the value of these objects to range from 0x00 to 0x1F.

Subindex	Bit 7	Bit 6	Bit 5	Bit 4	Bit 3	Bit 2	Bit 1	Bit 0
1	-	-	-	DI5	DI4	DI3	DI2	DI1

Table 5 Digital Input Bitmap

In all cases when talking about bit data, the following relationships hold true:

0 = OFF 1 = ON
 0 = FALSE 1 = TRUE
 0 = DISABLED 1 = ENABLED

When evaluating a DI, the controller will read the level (0,1) at the pin, and when it detects a change of state, the unit waits for the de-bounce time to elapse and then it passes the input to the rest of the function blocks. The de-bounce time is a fixed value of 30ms. This concept is illustrated in Figure 4.

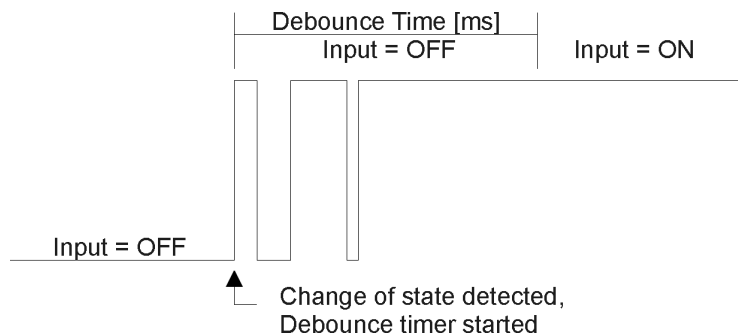

Figure 4 Digital Input Debouncing

Next, the controller looks at object **2002h, DI Latched** (default 0), and if TRUE the “Input State” of the input will toggle only on the rising edge of the input, as shown in Figure 5. This type of input could be used with a momentary push-button. Note: When 2002h is true, object 6002h is ignored.

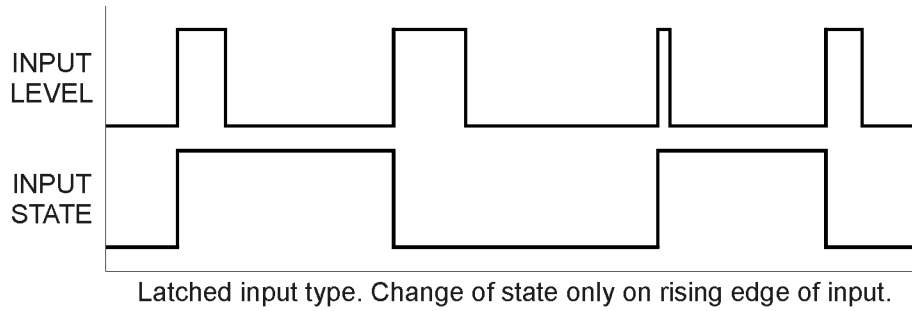

Figure 5 Digital Input Latched Logic

If not using latched logic, the controller then evaluates object **6002h, DI Polarity** (default 0). When it is ENABLED, the “Input State” will be the opposite of the “Input Level.”

The “Input State” value is written to object **6000h, DI Read Input** a read-only object that is mapped to TPDO1 by default, as outlined in Section 3.2.13. When TPDO1 is defined to be an event driven transmission type (default 255), the TPDO will only be sent after an “Input State” change is detected.

The AX021301 also has a pull up and pull down feature. Object 2000h **DI Pullup/Down Mode** will determine if the input signal is active high (10kΩ pulldown enabled, switch to +V) or active low (10kΩ pullup enabled, switched to GND) The options for object 2000h are shown in Table 6, with the default bolded.

Value	Meaning
0	Pullup/Down Disabled (high impedance input)
1	10kΩ Pullup Resistor Enabled (active low)
2	10kΩ Pulldown Resistor Enabled (active high)

Table 6 DI Pullup/Down Options

1.3. Description of Outputs

1.3.1. General Output Functionality

The digital outputs are high side (sourcing) switches that connect the load to the power supply voltage when the output is ON. They are individually protected against overcurrents and short circuits.

The outputs can have different types of functionalities. Object **2212h DO Output Type** is used to select different output types available on the AX021301. Table 7 shows the list of outputs types that can be selected.

Value	Output Type
0	Disabled
1	Digital (ON-OFF)
2	Pulsed
3	Timed
4	PWM

Table 7 List of Output Types

- Disabled** The output is disabled and it is turned OFF.
- Digital:** The output will toggle between OFF and ON states based on the states of the control source.
- Pulsed:** Similar to the digital output type, the pulsed output type is controlled by a digital ON-OFF state. However, unlike a digital output, when a pulsed output logic state is ON, the output will be turned on/off at the frequency set in object **2230h DO Output Frequency**, with the duty cycle set in object **2231 DO Duty Cycle**.
- Timed:** Similar to the digital output type, the pulsed output type is controlled by a digital ON-OFF state. However, unlike a digital output, when a timed output logic state comes ON, the output will be turned ON after the value in object **2240h DO Start Up Delay** has elapsed. The output will stay ON for the time set in object **2241h DO ON Time**, then shut off (even though the logic state is still ON). If object **2242h DO Timer Repeat** is TRUE, then the output will be OFF for the time set in object **2243h DO OFF Time** before coming back ON. The ON/OFF cycle will continue while the output logic state is still ON.
- PWM:** For this output type, the output will be switched at the frequency in object **2230h DO Output Frequency**. The duty cycle is fixed at minimum 0% and maximum 100%. The output PWM will be proportional to the input measured. The PWM output is linearly defined by the input minimum and maximum set in objects 2420h and 2421h.

1.3.2. Digital Output Function Block

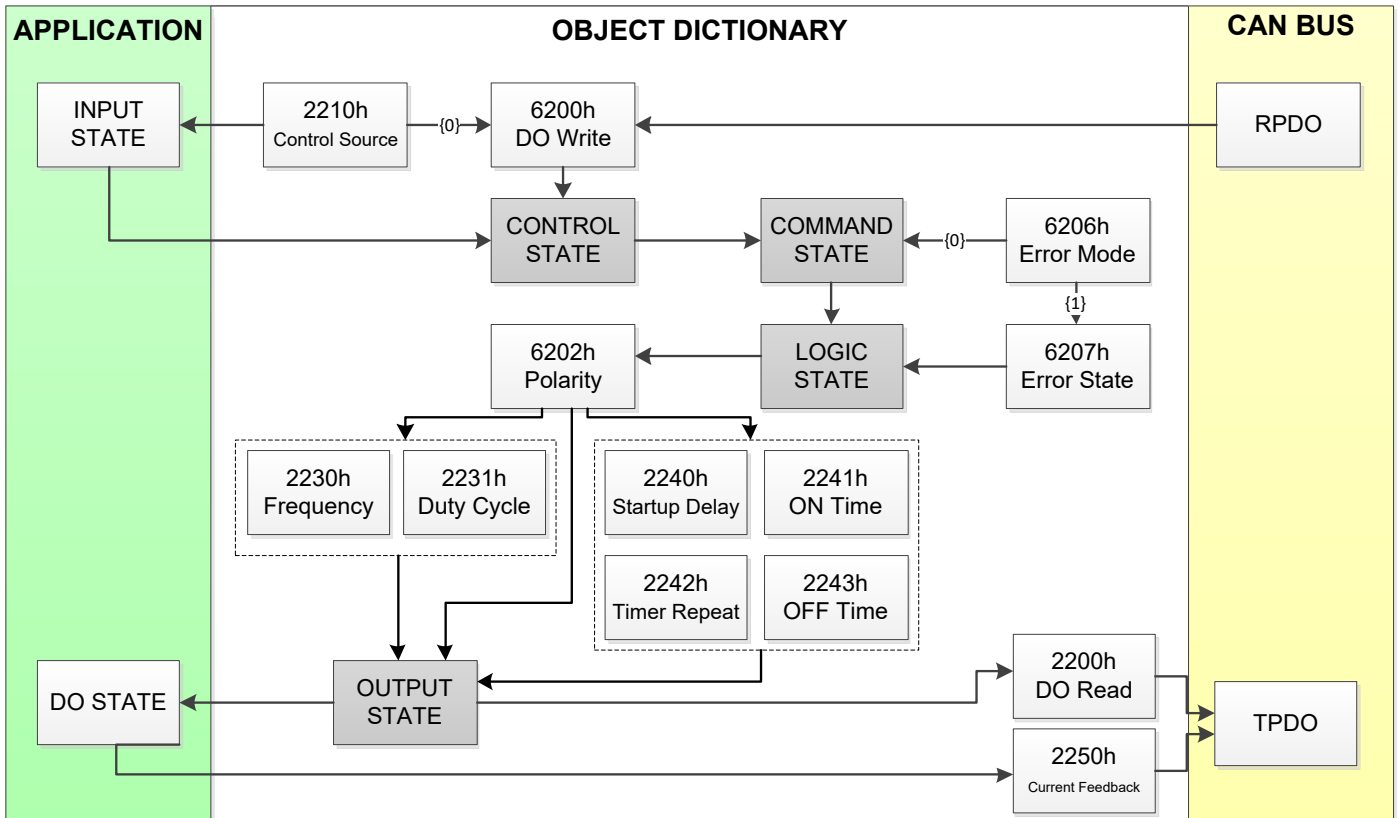

Figure 6 Digital Output Objects

For the digital outputs (DO), objects 2002h and 2200h are an 8-bit type. The table below shows the relationship between each bit and the corresponding digital output. This allows the value of these objects to range from 0x00 to 0x3F.

Subindex	Bit 7	Bit 6	Bit 5	Bit 4	Bit 3	Bit 2	Bit 1	Bit 0
1	-	-	DO6	DO5	DO4	DO3	DO2	DO1

Table 8 Digital Output Bitmap

When driving the outputs, the first thing the controller checks is that it is not in an error state by reading object **1001h, Error Register**. If an error is active, then object **6206h, DO Error Mode** (default 1) is evaluated, and if it is 1, then the “Logic State” is immediately set to the value in object **6207h, Error Value** (default 0). In this case, none of the other logic outlined below (except polarity) is applied.

If object 6206h is 0, then the output is kept the same even if the unit is in an error state.

If no errors are detected, then the outputs are controlled by object **2210h, DO Control Source**. Object 2210h has a value range between 0 to 5, where 0 means the unit is controlled through the RPDO, and 1 to 5 represents the input number. For example if the subindex 1 of object 2210h is changed to 3, it means the unit is configured to control output 1 using input 3.

When a subindex in 2210h is changed to 0, the output is controlled by the data in object **6200h, DO Write Output** (default 0) which is mapped to RPDO1 by default. Since PDOs do not exist in PRE-OPERATIONAL mode, the “Logic State” is always set OFF in this case. In OPERATIONAL mode, however, the “Logic State” will reflect the value in object 6200h.

Once the “Logic State” for the output has been established per the conditions above, object **6202h, DO Polarity** (default 0) is evaluated. When it is ENABLED, the “Output State” will be the opposite of the “Logic State.”

Since the “Output State” can reflect the opposite value of object 6200h because of the DO Polarity, object **2200h, DO Read Output** is a read-only object reflecting the actual output state of the output. This object is mapped to TPDO1 by default.

The controller has the capability to read the output current and it stores this value in object **2250h DO Current Feedback**. This output is mapped to TPDO1 by default.

1.4. Miscellaneous Function Block

Object **5555h, Start in Operational** (default 0) is provided as a ‘cheat’ when the unit is not intended to work with a CANopen® network (i.e. a stand-alone control), or is working on a network comprised solely as slaves so the OPERATION command will never be received from a master. By default this object is disabled (FALSE).

If the outputs are controlled by any of the inputs, the unit still needs to be in the OPERATIONAL mode for the outputs to be enabled. If desired, Object 5555h can be used to have the unit in OPERATIONAL mode at power up.

2. INSTALLATION INSTRUCTIONS

2.1. Dimensions and Pinout

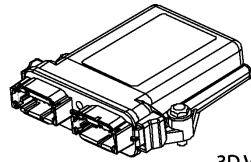

3D VIEW
Housing with 24 Pin Receptacle

HOUSING DIMENSIONS

Housing Material: High Temperature Nylon (Black)

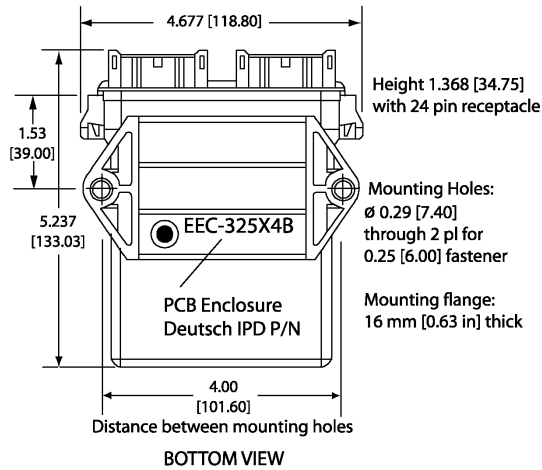

FRONT VIEW 24-PIN RECEPTACLE (NOT TO SCALE)

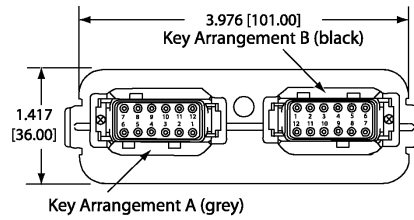

Mating Plug Assemblies for 24-pin receptacle:
Deutsch IPD P/N: DTM06-12SA and DTM06-12SB
with wedgelocks WM12S and contacts
(Contact factory for contact specification.)

Dimensions: inches [mm]
excluding mating plug(s)

Key Arrangement B (black)

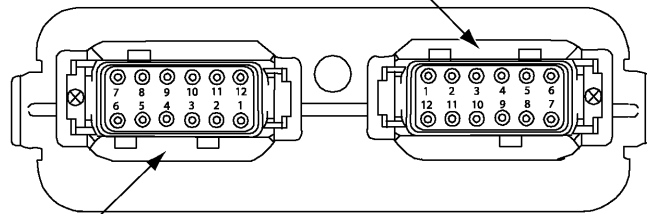

Key Arrangement A (grey)

FRONT VIEW 24 PIN RECEPTACLE

Grey Connector		Black Connector	
Pin #	Function	Pin #	Function
7	Output 1	1	Battery +
6	Ground 1	12	Battery -
8	Output 2	2	CANH
5	Ground 2	11	CANL
9	Output 3	3	RS-232 Transmit
4	Ground 3	4	RS-232 Receive
10	Output 4	5	Input 1 (Analog, AIN1/DIN1)
3	Ground 4	6	Input 2 (Analog, AIN2/DIN2)
11	Output 5	8	Input 3 (Frequency, FIN1/DIN3)
2	Ground 5	9	Input 4 (Frequency, FIN2/DIN4)
12	Output 6	10	Input 5 (Frequency, FIN3/DIN5)
1	Ground 6	7	Ground Reference

2.2. Installation Instructions

NOTES & WARNINGS

- Do not install near high-voltage or high-current devices.
- Note the operating temperature range. All field wiring must be suitable for that temperature range.
- Install the unit with appropriate space available for servicing and for adequate wire harness access (15 cm) and strain relief (30 cm).
- Do not connect or disconnect the unit while the circuit is live, unless the area is known to be non-hazardous.

MOUNTING

The module is designed for mounting on the valve block. If it is mounted without an enclosure, the controller should be mounted horizontally with connectors facing left or right, or with the connectors facing down, to reduce likelihood of moisture entry.

Mask all labels if the unit is to be repainted, so label information remains visible.

Mounting legs include holes sized for ¼” bolts. The bolt length will be determined by the end-user’s mounting plate thickness. Typically 20 mm (¾ inch) is adequate.

If the module is mounted away from the valve block, no wire or cable in the harness should exceed 30 meters in length. The power input wiring should be limited to 10 meters.

CONNECTIONS

Use the following TE Deutsch mating plugs to connect to the integral receptacles. Wiring to these mating plugs must be in accordance with all applicable local codes. Suitable field wiring for the rated voltage and current must be used. The rating of the connecting cables must be at least 85°C. For ambient temperatures below –10°C and above +70°C, use field wiring suitable for both minimum and maximum ambient temperature.

Refer to the respective TE Deutsch datasheets for usable insulation diameter ranges and other instructions.

Receptacle Contacts	Mating Sockets as appropriate (Refer to www.laddinc.com for more information on the contacts available for this mating plug.)
Mating Connector	DTM06-12SA, DTM06-12SB and wedges WM12S

NOISE – ELECTRICAL CONNECTIONS AND SHIELDING

To reduce noise, separate all power and output wires from those of the input and CAN. Shielded wires will protect against injected noise. Shield wires should be connected at the power or input source, or at the output load.

All wires used must be 18 or 20 AWG.

CAN NETWORK CONSTRUCTION

Axiomatic recommends that multi-drop networks be constructed using a “daisy chain” or “backbone” configuration with short drop lines.

CAN TERMINATION

It is necessary to terminate the network, therefore an external CAN termination is required. No more than two network terminators should be used on any one single network. A terminator is a 121Ω, 0.25 W, 1% metal film resistor placed between CAN_H and CAN_L terminals at the end two nodes on a network.

3. CANOPEN® OBJECT DICTIONARY

The CANopen® object dictionary of the AX021301 Controller is based on CiA device profile DS-401 V3.0 (device profile for generic I/O modules). The object dictionary includes Communication Objects beyond the minimum requirements in the profile, as well as several manufacturer-specific objects for extended functionality.

3.1. NODE ID and BAUD RATE

By default, the AX021301 Controller ships factory programmed with a Node ID = 127 (0x7F) and with Baud rate = 125 kbps.

3.1.1. LSS Protocol to Update

The only means by which the Node-ID and Baud rate can be changed is to use Layer Settling Services (LSS) and protocols as defined by CANopen® standard DS-305.

Follow the steps below to configure either variable using LSS protocol. If required, please refer to the standard for more detailed information about how to use the protocol.

3.1.1.1. Setting Node-ID

- Set the module state to LSS-configuration by **sending** the following message:

<i>Item</i>	<i>Value</i>
COB-ID	0x7E5
Length	2
Data 0	0x04 (cs=4 for switch state global)
Data 1	0x01 (switches to configuration state)

- Set the Node-ID by **sending** the following message:

<i>Item</i>	<i>Value</i>
COB-ID	0x7E5
Length	2
Data 0	0x11 (cs=17 for configure node-id)
Data 1	Node-ID (set new Node-ID as a hexadecimal number)

- The module will send the following response (any other response is a failure):

<i>Item</i>	<i>Value</i>
COB-ID	0x7E4
Length	3
Data 0	0x11 (cs=17 for configure node-id)
Data 1	0x00
Data 2	0x00

- Save the configuration by **sending** the following message:

<i>Item</i>	<i>Value</i>
COB-ID	0x7E5
Length	1
Data 0	0x17 (cs=23 for store configuration)

- The module will send the following response (any other response is a failure):

<i>Item</i>	<i>Value</i>
COB-ID	0x7E4
Length	3
Data 0	0x17 (cs=23 for store configuration)
Data 1	0x00
Data 2	0x00

- Set the module state to LSS-operation by **sending** the following message:
(Note, the module will reset itself back to the pre-operational state)

<i>Item</i>	<i>Value</i>
COB-ID	0x7E5
Length	2
Data 0	0x04 (cs=4 for switch state global)
Data 1	0x00 (switches to waiting state)

3.1.1.2. Setting Baudrate

- Set the module state to LSS-configuration by **sending** the following message:

<i>Item</i>	<i>Value</i>
COB-ID	0x7E5
Length	2
Data 0	0x04 (cs=4 for switch state global)
Data 1	0x01 (switches to configuration state)

- Set the baudrate by **sending** the following message:

<i>Item</i>	<i>Value</i>
COB-ID	0x7E5
Length	3
Data 0	0x13 (cs=19 for configure bit timing parameters)
Data 1	0x00 (switches to waiting state)
Data 2	Index (select baudrate index per table 9)

Index	Bit Rate
0	1 Mbit/s
1	800 kbit/s
2	500 kbit/s
3	250 kbit/s
4	125 kbit/s (default)
5	reserved (100 kbit/s)
6	50 kbit/s
7	20 kbit/s
8	10 kbit/s

Table 9 LSS Baudrate Indexes

- The module will send the following response (any other response is a failure):

Item	Value
COB-ID	0x7E4
Length	3
Data 0	0x13 (cs=19 for configure bit timing parameters)
Data 1	0x00
Data 2	0x00

- Activate bit timing parameters by **sending** the following message:

Item	Value
COB-ID	0x7E5
Length	3
Data 0	0x15 (cs=19 for activate bit timing parameters)
Data 1	<delay_lsb>
Data 2	<delay_msb>

The delay individually defines the duration of the two periods of time to wait until the bit timing parameters switch is done (first period) and before transmitting any CAN message with the new bit timing parameters after performing the switch (second period). The time unit of switch delay is 1 ms.

- Save the configuration by **sending** the following message (on the NEW baudrate):

Item	Value
COB-ID	0x7E5
Length	1
Data 0	0x17 (cs=23 for store configuration)

- The module will send the following response (any other response is a failure):

<i>Item</i>	<i>Value</i>
COB-ID	0x7E4
Length	3
Data 0	0x17 (cs=23 for store configuration)
Data 1	0x00
Data 2	0x00

- Set the module state to LSS-operation by **sending** the following message:
(Note, the module will reset itself back to the pre-operational state)

<i>Item</i>	<i>Value</i>
COB-ID	0x7E5
Length	2
Data 0	0x04 (cs=4 for switch state global)
Data 1	0x00 (switches to waiting state)

3.2. COMMUNICATION OBJECTS (DS-301 and DS-401)

The communication objects supported by the AX021301 Controller are listed in the following table. A more detailed description of some of the objects is given in the following subchapters. Only those objects that have device-profile specific information are described. For more information on the other objects, refer to the generic CANopen® protocol specification DS-301.

Index (hex)	Object	Object Type	Data Type	Access	PDO Mapping
1000	Device Type	VAR	UNSIGNED32	RO	No
1001	Error Register	VAR	UNSIGNED8	RO	No
1003	Pre-Defined Error Field	ARRAY	UNSIGNED32	RO	No
100C	Guard Time	VAR	UNSIGNED16	RO	No
100D	Life Time Factor	VAR	UNSIGNED8	RO	No
1010	Store Parameters	ARRAY	UNSIGNED32	RW	No
1011	Restore Default Parameters	ARRAY	UNSIGNED32	RW	No
1016	Consumer Heartbeat Time	ARRAY	UNSIGNED32	RW	No
1017	Producer Heartbeat Time	VAR	UNSIGNED16	RW	No
1018	Identity Object	RECORD		RO	No
1020	Verify Configuration	ARRAY	UNSIGNED32	RW	No
1029	Error Behaviour	ARRAY	UNSIGNED8	RW	No
1400	RPDO1 Communication Parameter	RECORD		RW	No
1401	RPDO2 Communication Parameter	RECORD		RW	No
1600	RPDO1 Mapping Parameter	RECORD		RW	No
1601	RPDO2 Mapping Parameter	RECORD		RW	No
1800	TPDO1 Communication Parameter	RECORD		RW	No
1801	TPDO2 Communication Parameter	RECORD		RW	No
1A00	TPDO1 Mapping Parameter	RECORD		RW	No
1A01	TPDO2 Mapping Parameter	RECORD		RW	No

3.2.1. Object 1000h: Device Type

This object contains information about the device type as per device profile DS-401. The 32-bit parameter is divided into two 16-bit values, showing General and Additional information as shown below.

MSB	LSB
Additional Information = 0x0007	General Information = 0x0191 (401)

DS-401 defines the Additional Information field in the following manner:

- 0000h = invalid, not allowed
- 0001h = digital input(s) implemented (1b = implemented)
- 0002h = digital output(s) implemented (1b = implemented)
- 0004h = analogue input(s) implemented (0b = not implemented)
- 0008h = analogue output(s) implemented (0b = not implemented)

- 0010h = reserved
- 0020h = reserved
- 0040h = reserved
- 0080h = (Mapping of PDOs) (0b = pre-defined, generic PDO mapping is supported)

- 00xxh = specific functionality (00h = no specific joystick function)

Object Description

Index	1000h
Name	Device Type
Object Type	VAR
Data Type	UNSIGNED32

Entry Description

Access	RO
PDO Mapping	No
Value Range	0x00070191
Default Value	0x00070191

3.2.2. Object 1001h: Error Register

This object is an error register for the device. Any time there is an error detected by the AX021301 Controller, the Generic Error Bit (bit 0) is set. Only if there is no errors in the module will this bit will be cleared. No other bits in this register are used by the Controller.

Object Description

Index	1001h
Name	Error Register
Object Type	VAR
Data Type	UNSIGNED8

Entry Description

Access	RO
PDO Mapping	No
Value Range	00h or 01h
Default Value	0

3.2.3. Object 1003h: Pre-Defined Error Field

This object provides an error history by listing the errors in the order that they have occurred. An error is added to the top of the list when it occurs, and is immediately removed when the error condition has been cleared. The latest error is always at sub-index 1, with sub-index 0 containing the number of errors currently in the list. When the device is in an error-free state, the value of sub-index 0 is zero.

The error list may be cleared by writing a zero to sub-index 0, which will clear all errors from the list, regardless of whether or not they are still present. Clearing the list does NOT mean that the module will return to the error-free behaviour state if at least one error is still active.

This controller can show up to 10 errors in the list. If the device registers more errors, the list will be truncated, and the oldest entries will be lost.

The error codes stored in the list are 32-bit unsigned numbers, consisting of two 16-bit fields. The lower 16-bit field is the EMCY error code, and the higher 16-bit field is a manufacturer-specific code. The manufacturer-specific code is divided into two 8-bit fields, with the higher byte indicating the error description, and the lower byte indicating the channel on which the error occurred.

MSB		LSB
Error Description	Channel-ID	EMCY Error Code

Only if a heartbeat consumer fails to be received within the expected timeframe will the Channel-ID (nn) reflect the Node-ID of the consumer channel that was not producing. Otherwise, this field is set to 00h. In all cases, the Error Descriptions bits will be set to 00h. Table 10 outlines all the possible error codes generated by the AX021301 and their associated meaning.

Code	Error Description	Meaning	ID	Meaning	EMCY Code	Meaning
00000000h	EMCY Error Reset (fault no longer active)					
00008100h	00h	Unspecified	00h	Unspecified	8100h	RPDO Timeout
10008130h	10h	Lifeguard Event	00h	Unspecified	8130h	Lifeguard/Heartbeat Error
80nn8130h	80h	Heartbeat Timeout	nn	Node-ID	8130h	Lifeguard/Heartbeat Error
20003000h	20h	Positive Overload (Vps Overvoltage)	00h	Unspecified	3000h	Supply Voltage
40003000h	40h	Negative Overload (Vps Undervoltage)	00h	Unspecified	3000h	Supply Voltage
2001F001h	20h	Positive Overload (Out of Range High)	01h	Analog Input 1	F001h	Input Overload
4002F001h	40h	Negative Overload (Out of Range Low)	01h	Analog Input 1	F001h	Input Overload
2002F001h	20h	Positive Overload	02h	Analog Input 2	F001h	Input Overload
4002F001h	40h	Negative Overload	02h	Analog Input 2	F001h	Input Overload
1001F002h	01h	Open/Short Circuit	01h	Output 1	F002h	Output Overload
1002F002h	01h	Open/Short Circuit	02h	Output 2	F002h	Output Overload
1004F002h	01h	Open/Short Circuit	04h	Output 3	F002h	Output Overload
1008F002h	01h	Open/Short Circuit	08h	Output 4	F002h	Output Overload
1010F002h	01h	Open/Short Circuit	10h	Output 5	F002h	Output Overload
1020F002h	01h	Open/Short Circuit	20h	Output 6	F002h	Output Overload

Table 10 Pre-Defined Error Field Codes

Object Description

Index	1003h
Name	Pre-Defined Error Field
Object Type	ARRAY
Data Type	UNSIGNED32

Entry Description

Sub-Index	0h
Description	Number of entries
Access	RW
PDO Mapping	No
Value Range	0 to 10
Default Value	0

Sub-Index	1h to 3h
Description	Standard error field
Access	RO
PDO Mapping	No
Value Range	UNSIGNED32
Default Value	0

3.2.4. Object 100Ch and 100Dh: Guard Time and Lifetime Factor

The objects at index 100Ch and 100Dh have been provided for backwards compatibility. However, since the standard recommends that newer networks do not use the life guarding protocol, but rather heartbeat monitoring instead, these objects are defined as read-only and are therefore not relevant in this product.

Object Description

Index	100Ch
Name	Guard Time
Object Type	VAR
Data Type	UNSIGNED16

Index	100Dh
Name	Life time factor
Object Type	VAR
Data Type	UNSIGNED8

Entry Description

Sub-Index	0h
Access	RO
PDO Mapping	No
Value Range	No
Default Value	0

Sub-Index	0h
Access	RO
PDO Mapping	No
Value Range	No
Default Value	0

3.2.5. Object 1010h: Store Parameters

This object supports the saving of parameters in non-volatile memory. In order to avoid storage of parameters by mistake, storage is only executed when a specific signature is written to the appropriate sub-index. The signature is “save”.

The signature is a 32-bit unsigned number, composed of the ASCII codes of the signature characters, according to the following table:

MSB		LSB	
e	v	a	s
65h	76h	61h	73h

On reception of the correct signature to an appropriate sub-index, the AX021301 Controller will store the parameters in non-volatile memory, and then confirm the SDO transmission.

By read access, the object provides information about the module’s saving capabilities. For all sub-indexes, this value is 1h, indicating that the AX021301 Controller saves parameters on command.

This means that if power is removed before the Store object is written, changes to the Object Dictionary will NOT have been saved in the non-volatile memory, and will be lost on the next power cycle.

Object Description

Index	1010h
Name	Store Parameters
Object Type	ARRAY
Data Type	UNSIGNED32

Entry Description

Sub-Index	0h
Description	Largest sub-index supported
Access	RO
PDO Mapping	No
Value Range	4
Default Value	4

Sub-Index	1h
Description	Save all parameters
Access	RW
PDO Mapping	No
Value Range	0x65766173 (write access) 1h (read access)
Default Value	1h

Sub-Index	2h
Description	Save communication parameters
Access	RW
PDO Mapping	No
Value Range	0x65766173 (write access) 1h (read access)
Default Value	1h

Sub-Index	3h
Description	Save application parameters
Access	RW
PDO Mapping	No
Value Range	0x65766173 (write access) 1h (read access)
Default Value	1h

Sub-Index	4h
Description	Save manufacturer parameters
Access	RW
PDO Mapping	No
Value Range	0x65766173 (write access) 1h (read access)
Default Value	1h

3.2.6. Object 1011h: Restore Parameters

This object supports the restoring of the default values for the object dictionary in non-volatile memory. In order to avoid restoring of parameters by mistake, the device restores the defaults only when a specific signature is written to the appropriate sub-index. The signature is “load”.

The signature is a 32-bit unsigned number, composed of the ASCII codes of the signature characters, according to the following table:

MSB		LSB	
d	a	o	l
64h	61h	6Fh	6Ch

On reception of the correct signature to an appropriate sub-index, the AX021301 Controller will restore the defaults in non-volatile memory, and then confirm the SDO transmission. **The default values are set valid only after the device is reset or power-cycled.** This means that the AX021301 Controller will NOT start using the default values right away, but rather continue to run from whatever values were in the Object Dictionary prior to the restore operation.

By read access, the object provides information about the module’s default parameter restoring capabilities. For all sub-indexes, this value is 1h, indicating that the AX021301 Controller restores defaults on command.

Object Description

Index	1011h
Name	Restore Default Parameters
Object Type	ARRAY
Data Type	UNSIGNED32

Entry Description

Sub-Index	0h
Description	Largest sub-index supported
Access	RO
PDO Mapping	No
Value Range	4
Default Value	4

Sub-Index	1h
Description	Restore all default parameters
Access	RW
PDO Mapping	No
Value Range	0x64616F6C (write access), 1h (read access)
Default Value	1h

Sub-Index	2h
Description	Restore default communication parameters
Access	RW
PDO Mapping	No
Value Range	0x64616F6C (write access), 1h (read access)
Default Value	1h

Sub-Index	3h
Description	Restore default application parameters
Access	RW
PDO Mapping	No
Value Range	0x64616F6C (write access), 1h (read access)
Default Value	1h

Sub-Index	4h
Description	Restore default manufacturer parameters
Access	RW
PDO Mapping	No
Value Range	0x64616F6C (write access), 1h (read access)
Default Value	1h

3.2.7. Object 1016h: Consumer Heartbeat Time

The AX021301 Controller can be a consumer of heartbeat objects for up to one module. This object defines the expected heartbeat cycle time for that module, and if set to zero, it is not used. When non-zero, the time is a multiple of 1ms, and monitoring will start after the reception of the first heartbeat from the module. If the AX021301 Controller fails to receive a heartbeat from a node in the expected timeframe, it will indicate a communication error, and respond as per object 1029h.

Bits	31-24	23-16	15-0
Value	Reserved 00h	Node-ID	Heartbeat time
Encoded as		UNSIGNED8	UNSIGNED16

Object Description

Index	1016h
Name	Consumer heartbeat time
Object Type	ARRAY
Data Type	UNSIGNED32

Entry Description

Sub-Index	0h
Description	Number of entries
Access	RO
PDO Mapping	No
Value Range	4
Default Value	4

Sub-Index	1h to 4h
Description	Consumer heartbeat time
Access	RW
PDO Mapping	No
Value Range	UNSIGNED32
Default Value	0

3.2.8. Object 1017h: Producer Heartbeat Time

The AX021301 Controller could be configured to produce a cyclical heartbeat by writing a non-zero value to this object. The value will be given in multiples of 1ms, and a value of 0 shall disable the heartbeat.

Object Description

Index	1017h
Name	Producer heartbeat time
Object Type	VAR
Data Type	UNSIGNED16

Entry Description

Sub-Index	0h
Access	RW
PDO Mapping	No
Value Range	10 to 65535
Default Value	0

3.2.9. Object 1018h: Identity Object

The identity object indicates the data of the AX021301 Controller, including vendor id, device id, software and hardware version numbers, and the serial number.

In the Revision Number entry at sub-index 3, the format of the data is as shown below

MSB	LSB
Major revision number (object dictionary)	Hardware Revision Software Version

Object Description

Index	1018h
Name	Identity Object
Object Type	RECORD
Data Type	Identity Record

Entry Description

Sub-Index	0h
Description	Number of entries
Access	RO
PDO Mapping	No
Value Range	4
Default Value	4

Sub-Index	1h
Description	Vendor ID
Access	RO
PDO Mapping	No
Value Range	0x00000055
Default Value	0x00000055 (Axiomatic)

Sub-Index	2h
Description	Product Code
Access	RO
PDO Mapping	No
Value Range	0x00011103
Default Value	0x00011103

Sub-Index	3h
Description	Revision Number
Access	RO
PDO Mapping	No
Value Range	UNSIGNED32
Default Value	0x00010201

Sub-Index	4h
Description	Serial Number
Access	RO
PDO Mapping	No
Value Range	UNSIGNED32
Default Value	No

3.2.10. Object 1020h: Verify Configuration

This object can be read to see what date the software (version identified in object 1018h) was compiled. The date is represented as a hexadecimal value showing day/month/year as per the format below. The time value at sub-index 2 is a hexadecimal value showing the time in a 24 hour clock

MSB	LSB	
Day (in 1-Byte Hex)	Month (in 1-Byte Hex)	Year (in 2-Byte Hex)
00	00	Time (in 2-Byte Hex)

For example, a value of 0x10082010 would indicate that the software was compiled on August 10th, 2010. A time value of 0x00001620 would indicate it was compiled at 4:20pm.

Object Description

Index	1020h
Name	Verify configuration
Object Type	ARRAY
Data Type	UNSIGNED32

Entry Description

Sub-Index	0h
Description	Number of entries
Access	RO
PDO Mapping	No
Value Range	2
Default Value	2

Sub-Index	1h
Description	Configuration date
Access	RO
PDO Mapping	No
Value Range	UNSIGNED32
Default Value	No

Sub-Index	2h
Description	Configuration time
Access	RO
PDO Mapping	No
Value Range	UNSIGNED32
Default Value	No

3.2.11. Object 1029h: Error Behaviour

This object controls the node state that the AX021301 Controller will be set into in case of an error of the type associated with the sub-index.

A CAN overrun fault is flagged when an RPDO is not received within the expected time period defined in the “Event Timer” of the associated communication object (see Section 3.2.12 for more information.) If a heartbeat message is not received as expected (see Section 3.2.8), a Heartbeat Error is flagged.

For all sub-indexes, the following definitions hold true:

- 0 = Pre-Operational (node reverts to a pre-operational state when this fault is detected)
- 1 = No State Change (node remains in the same state it was in when the fault occurred)
- 2 = Stopped (node goes into stopped mode when the fault occurs)

Object Description

Index	1029h
Name	Error Behaviour
Object Type	ARRAY
Data Type	UNSIGNED8

Entry Description

Sub-Index	0h
Description	Number of entries
Access	RO
PDO Mapping	No
Value Range	5
Default Value	5

Sub-Index	1h
Description	Communication Fault
Access	RW
PDO Mapping	No
Value Range	See above
Default Value	0 (Pre-operational)

Sub-Index	2h
Description	Input Fault
Access	RW
PDO Mapping	No
Value Range	See above
Default Value	1 (No State Change)

Sub-Index	3h
Description	Output Fault
Access	RW
PDO Mapping	No
Value Range	See above
Default Value	1 (No State Change)

Sub-Index	4h
Description	Output Fault
Access	RW
PDO Mapping	No
Value Range	See above
Default Value	1 (No State Change)

3.2.12. RPDO Behaviour

Per the CANopen® standard DS-301, the following procedure shall be used for re-mapping, and is the same for both RPDOs and TPDOs.

- a) Destroy the PDO by setting bit **exists** (most significant bit) of sub-index 01h of the according PDO communication parameter to 1b
- b) Disable mapping by setting sub-index 00h of the corresponding mapping object to 0
- c) Modify the mapping by changing the values of the corresponding sub-indices
- d) Enable mapping by setting sub-index 00h to the number of mapped objects
- e) Create the PDO by setting bit **exists** (most significant bit) of sub-index 01h of the according PDO communication parameter to 0b

The AX021301 Controller supports up to two RPDO messages for compatibility with DS-301, but only the first RPDO is useable. RPDO1 is set according to the pre-defined connection set described in DS-401. The other RPDO do not exist and is defined as a read-only object so it is not changeable. RPDO1 uses the default mapping defined in DS-401.

RPDO1 Mapping at Object 1600h: Default ID 0x200 + Node ID

Sub-Index	Value	Object
0	1	Number of mapped application objects in PDO
1	0x62000108	DO Write Output 8-bit (DO1 to DO6)
2	0	Not used by default
3	0	Not used by default
4	0	Not used by default
5	0	Not used by default
6	0	Not used by default
7	0	Not used by default
8	0	Not used by default

RPDO2 Mapping at Object 1601h: Default ID 0x300 + Node ID

Sub-Index	Value	Object
0	0	Number of mapped application objects in PDO
1	0	Not used by default
2	0	Not used by default
3	0	Not used by default
4	0	Not used by default
5	0	Not used by default
6	0	Not used by default
7	0	Not used by default
8	0	Not used by default

On RPDO1, there is no RTR allowed, it uses 11-bit CAN-IDs (base frame valid) and it is event-driven (transmission type = 255). By default, it does not have the timeout feature enabled, i.e. the “Event Timer” on sub-index 5 is set to zero. When this is changed to a non-zero value, if the RPDO has not been received from another node within the time period defined (while in Operational mode), a network fault is activated, and the controller will go to the operational state define in Object 1029h sub-index 3.

Object Description

Index	1400h to 1403h
Name	RPDO communication parameter
Object Type	RECORD
Data Type	PDO Communication Record

Entry Description

Sub-Index	0h
Description	Number of entries
Access	RO
PDO Mapping	No
Value Range	5
Default Value	5

Sub-Index	1h
Description	COB-ID used by RPDO
Access	RW
PDO Mapping	No
Value Range	See value definition in DS-301
Default Value	40000000h + RPDO1 + Node ID C0000000h + RPDO2 + Node-ID

X	RPDOx ID
1	0200h
2	0300h

Node-ID = Node-ID of the module. The RPDO COB-IDs are automatically updated if the Node-ID is changed by LSS protocol.

80000000h in the COB-ID indicates that the PDO does not exist (destroyed)

04000000h in the COB-ID indicates that there is no RTR allowed on the PDO

Sub-Index	2h
Description	Transmission type
Access	RO
PDO Mapping	No
Value Range	See value definition in DS-301
Default Value	255 (FFh) = Event Driven

Sub-Index	3h
Description	Inhibit Time
Access	RO
PDO Mapping	No
Value Range	See value definition in DS-301
Default Value	0

Sub-Index	4h
Description	Compatibility entry
Access	RO
PDO Mapping	No
Value Range	UNSIGNED8
Default Value	0

Sub-Index	5
Description	Event-timer
Access	RW
PDO Mapping	No
Value Range	See value definition in DS-301
Default Value	0

Recall: A non-zero event timer for an RPDO means that it will result in a network fault being flagged if it has not been received within this timeframe while in Operational mode.

3.2.13. TPDO Behaviour

The AX021301 Controller supports up to two TPDO messages for compatibility with DS-301. TPDO1 is set according to the pre-defined connection set described in DS-401. It also transmits the current feedback of each digital output. TPDO2 is configured to transmit the analog input measured value.

TPDO1 Mapping at Object 1A00h: Default ID 0x180 + Node ID

Sub-Index	Value	Object
0	8	Number of mapped application objects in PDO
1	0x60000108	DI Read Object 8-bit (DI1 to DI5)
2	0x22000108	DO Read Object 8-bit (DO1 to DO6)
3	0x22500108	DO1 Current Feedback
4	0x22500208	DO2 Current Feedback
5	0x22500308	DO3 Current Feedback
6	0x22500408	DO4 Current Feedback
7	0x22500508	DO5 Current Feedback
8	0x22500608	DO6 Current Feedback

TPDO2 Mapping at Object 1A01h: Default ID 0x280 + Node ID

Sub-Index	Value	Object
0	2	Number of mapped application objects in PDO
1	0x64010110	AI Read Input
2	0x64010210	AI Read Input
3	0	Not used by default
4	0	Not used by default
5	0	Not used by default
6	0	Not used by default
7	0	Not used by default
8	0	Not used by default

On TPDO1, there is no RTR allowed, it uses 11-bit CAN-IDs (base frame valid) and it is event-driven by interrupts (transmission type = 255, i.e. when a DI changes state). Alternatively, it can be set for a time based response by changing the transmission type to 254, and changing the “Event Timer” on sub-index 5 to a non-zero value. In this case, the TPDO1 will automatically be broadcasted every X milliseconds (as defined by the value in the event timer) while the unit is in the OPERATIONAL mode.

Object Description

Index	1800h to 1803h
Name	TPDO communication parameter
Object Type	RECORD
Data Type	PDO Communication Record

Entry Description

Sub-Index	0h
Description	Number of entries
Access	RO
PDO Mapping	No

Value Range	5
Default Value	5

Sub-Index	1h
Description	COB-ID used by TPDO
Access	RW
PDO Mapping	No
Value Range	See value definition in DS-301
Default Value	40000000h + TPDO1 + Node-ID C0000000h + TPDO2 + Node-ID

X	TPDOx ID
1	0180h
2	0280h

Node-ID = Node-ID of the module. The TPDO COB-IDs are automatically updated if the Node-ID is changed by LSS protocol.

80000000h in the COB-ID indicates that the PDO does not exist (destroyed)

04000000h in the COB-ID indicates that there is no RTR allowed on the PDO

Sub-Index	2h
Description	Transmission type
Access	RO
PDO Mapping	No
Value Range	254 (FEh) = Event Driven, Timed 255 (FFh) = Event Driven, Interrupts
Default Value	255 (FFh) = Event Driven, Interrupts

Sub-Index	3h
Description	Inhibit Time
Access	RO
PDO Mapping	No
Value Range	See value definition in DS-301
Default Value	0

Sub-Index	4h
Description	Compatibility entry
Access	RO
PDO Mapping	No
Value Range	UNSIGNED8
Default Value	0

Sub-Index	5
Description	Event-timer
Access	RW
PDO Mapping	No
Value Range	See value definition in DS-301
Default Value	0ms

Recall: A non-zero event timer for a TPDO is only valid with transmission type = 254 while in Operational mode

3.3. APPLICATION OBJECTS (DS-401)

Index (hex)	Object	Object Type	Data Type	Access	PDO Mapping
6000h	DI Read Input 8-bit	ARRAY	UNSIGNED8	RO	Yes
6002h	DI Polarity 8-bit	ARRAY	UNSIGNED8	RW	No
6200h	DO Write Output 8-bit	ARRAY	UNSIGNED8	RW	Yes
6202h	DO Polarity 8-bit	ARRAY	UNSIGNED8	RW	No
6206h	DO Error Mode 8-bit	ARRAY	UNSIGNED8	RW	No
6207h	DO Error Value 8-bit	ARRAY	UNSIGNED8	RW	No
6220h	DO Write Output Bit	ARRAY	UNSIGNED8	RW	Yes
6401h	Read Analog Input	ARRAY	INTEGER16	RO	Yes
6431h	Analog Input Offset	ARRAY	INTEGER16	RW	No
6432h	Analog Input Pre-scale	ARRAY	INTEGER16	RW	No

3.3.1. Object 6000h: DI Read Input 8-bit

This read-only object represents the digital input state from 5 input lines. Refer to Section 1.2.2 for more information. See Table 5 for bit order within the bytes. This object is mapped to TPDO1 by default.

Object Description

Index	6000h
Name	DI Read Input 8-bit
Object Type	VAR
Data Type	UNSIGNED8

Entry Description

Sub-Index	0h
Description	Number of entries
Access	RO
PDO Mapping	No
Value Range	1
Default Value	1

Sub-Index	1h
Description	DI1 to DI5 State
Access	RO
PDO Mapping	Yes
Value Range	1Fh (31) [0001 1111b]
Default Value	No

3.3.2. Object 6002h: DI Polarity 8-bit

This object defines the polarity of a group of 5 input lines. Input polarity can be inverted individually.

1 = input inverted 0 = input not inverted

Object Description

Index	6002h
Name	DI Polarity 8-bit
Object Type	VAR
Data Type	UNSIGNED8

Entry Description

Sub-Index	0h
Description	Number of entries
Access	RO
PDO Mapping	No
Value Range	1
Default Value	1

Sub-Index	1h
Description	DI1 to DI5 Polarity
Access	RW
PDO Mapping	No
Value Range	1Fh (31) [0001 1111b]
Default Value	00h (0) [0000 0000b]

3.3.3. Object 6200h: DO Write Output 8-bit

This object shall set a group of 6 output lines as a byte of information. Each output can be turned ON/OFF individually. See Table 8 in Section 1.3.2 for bit order within the bytes. This object is mapped to RPDO1 by default.

1 = output ON (relay engaged) 0 = output OFF

Object Description

Index	6200h
Name	DO Write Output 8-bit
Object Type	ARRAY
Data Type	UNSIGNED8

Entry Description

Sub-Index	0h
Description	Number of entries
Access	RO
PDO Mapping	No
Value Range	1
Default Value	1

Sub-Index	1h		
Description	DO1 to DO6 Write Output		
Access	RW		
PDO Mapping	Yes		
Value Range	3Fh	(63)	[0011 1111b]
Default Value	00h	(0)	[0000 0000b]

3.3.4. Object 6202h: DO Polarity 8-bit

This object defines the polarity of a group of 6 output lines. Output polarity can be inverted individually.

1 = output inverted 0 = output not inverted

Object Description

Index	6202h
Name	DO Polarity 8-bit
Object Type	ARRAY
Data Type	UNSIGNED8

Entry Description

Sub-Index	0h
Description	Number of entries
Access	RO
PDO Mapping	No
Value Range	1
Default Value	1

Sub-Index	1h		
Description	DO1 to DO6 Polarity		
Access	RW		
PDO Mapping	No		
Value Range	3Fh	(63)	[0011 1111b]
Default Value	00h	(0)	[0000 0000b]

3.3.5. Object 6206h: DO Error Mode 8-bit

This object indicates, whether an output is set to a pre-defined error value (see 6207h object) in case of an internal device failure or a 'Stop Remote Node' indication, for a group of 6 output lines.

1 = output value shall take the pre-defined condition specified in 6207h object

0 = output value shall be kept if an error occurs

Object Description

Index	6206h
Name	DO Error Mode 8-bit
Object Type	ARRAY
Data Type	UNSIGNED8

Entry Description

Sub-Index	0h
Description	Number of entries
Access	RO
PDO Mapping	No
Value Range	1
Default Value	1

Sub-Index	1h
Description	DO1 to DO6 Error Mode
Access	RW
PDO Mapping	No
Value Range	3Fh (63) [0011 1111b]
Default Value	3Fh (63) [0011 1111b]

3.3.6. Object 6207h: DO Error Value 8-bit

On condition that the corresponding Error Mode bit is active, device failures shall set the outputs to the value configured by this object for a group of 6 output lines

1 = output ON in error mode (relay engaged) 0 = output OFF in error mode

Object Description

Index	6207h
Name	DO Error Value 8-bit
Object Type	ARRAY
Data Type	UNSIGNED8

Entry Description

Sub-Index	0h
Description	Number of entries
Access	RO
PDO Mapping	No
Value Range	1
Default Value	1

Sub-Index	1h
Description	DO1 to DO8 Error Value
Access	RW
PDO Mapping	No
Value Range	3Fh (63) [0011 1111b]
Default Value	00h (0) [0000 0000b]

3.3.7. Object 6220h: DO Write Output Bit

This object sets the single output line information. The value of each subindex corresponds to its respective bit in object 6200h. This object only accepts Boolean data; however, if the output type of an output is changed to a PWM output, the value can be changed with the range 0 to 250, which is used to control the output PWM duty cycle proportionally to this data.

Object Description

Index	6220h
Name	DO Write Output Bit
Object Type	ARRAY
Data Type	UNSIGNED8

Entry Description

Sub-Index	0h
Description	Number of entries
Access	RO
PDO Mapping	No
Value Range	6
Default Value	6

Sub-Index	1h to 6h
Description	DO1 to DO6 Write Output
Access	RW
PDO Mapping	Yes
Value Range	TRUE or FALSE 0h to FAh if output type is PWM
Default Value	FALSE

3.3.8. Object 6401h: Read Analog Input

This object reads the measured values of the analog inputs and stores the values in the respective subindex. The measured value is in an INTEGER16 format and can be scaled using objects 6431h (Analog Input Offset) and 6432h (Analog Input Pre-scale). By default, this object is mapped to TPDO2.

Object Description

Index	6401h
Name	DO Read Analog Input
Object Type	ARRAY
Data Type	INTEGER16

Entry Description

Sub-Index	0h
Description	Number of entries
Access	RO
PDO Mapping	No
Value Range	2
Default Value	2

Sub-Index	1h to 2h
-----------	----------

Description	AI1 to AI2 Read Input
Access	RO
PDO Mapping	Yes
Value Range	INTEGER16
Default Value	No

3.3.9. Object 6431h: Analog Input Offset

This object is used to offset the measured analog input value. The offset affects the value object 6401h.

Object Description

Index	6431h
Name	Analog Input Offset
Object Type	ARRAY
Data Type	INTEGER16

Entry Description

Sub-Index	0h
Description	Number of entries
Access	RO
PDO Mapping	No
Value Range	2
Default Value	2

Sub-Index	1h to 2h
Description	AI1 to AI2 Input Offset
Access	RW
PDO Mapping	No
Value Range	INTEGER16
Default Value	0

3.3.10. Object 6432h: Analog Input Pre-scale

This object is used to set the pre-scale for the measured analog input value. The pre-scale affects the value object 6401h.

Object Description

Index	6432h
Name	Analog Input Pre-scale
Object Type	ARRAY
Data Type	INTEGER16

Entry Description

Sub-Index	0h
Description	Number of entries
Access	RO
PDO Mapping	No
Value Range	2
Default Value	2

Sub-Index	1h to 2h
Description	AI1 to AI2 Input Pre-scale
Access	RW
PDO Mapping	No
Value Range	INTEGER16
Default Value	1

3.4. MANUFACTURER OBJECTS

Index (hex)	Object	Object Type	Data Type	Access	PDO Mapping
2000	DI Pull Up Pull Down	ARRAY	UNSIGNED8	RW	No
2002	DI Latched 8-bit	ARRAY	UNSIGNED8	RW	No
2200	DO Read Output 8-bit	ARRAY	UNSIGNED8	RO	Yes
2210	DO Control Source	ARRAY	UNSIGNED8	RW	No
2212	DO Output Type	ARRAY	UNSIGNED8	RW	No
2230	DO Output Frequency	ARRAY	UNSIGNED8	RW	No
2231	DO Output Duty Cycle	ARRAY	UNSIGNED8	RW	No
2240	DO Output Startup Delay	ARRAY	UNSIGNED16	RW	No
2241	DO Output ON Time	ARRAY	UNSIGNED16	RW	No
2242	DO Output Timer Repeat	ARRAY	UNSIGNED8	RW	No
2243	DO Output OFF Time	ARRAY	UNSIGNED16	RW	No
2250	DO Output Current Feedback	ARRAY	UNSIGNED8	RO	Yes
2400	AI Input Type	ARRAY	UNSIGNED8	RW	No
2410	AI Input Range	ARRAY	UNSIGNED8	RW	No
2420	AI Minimum	ARRAY	INTEGER16	RW	No
2421	AI Maximum	ARRAY	INTEGER16	RW	No
2430	AI Decimal Digits	ARRAY	UNSIGNED8	RW	No
2440	AI Filter Type	ARRAY	UNSIGNED8	RW	No
2441	AI Filter Constant	ARRAY	UNSIGNED16	RW	No
2600	ADC Filter Frequency	VAR	UNSIGNED8	RW	No
2601	Power Supply Under Voltage	VAR	UNSIGNED16	RW	No
2602	Power Supply Over Voltage	VAR	UNSIGNED16	RW	No
2651	Error Reaction Delay	ARRAY	UNSIGNED16	RW	No
2652	Error Hysteresis	ARRAY	INTEGER16	RW	No
5020	Power Supply Voltage	VAR	FLOAT	RO	Yes
5555	Start in Operational Mode	VAR	UNSIGNED8	RW	No

3.4.1. Object 2000h: DI Pull Up Pull Down

This object determines how the state read on the input pin corresponds to the logic state. The options for this object are listed in Table 5, and the controller will adjust the input hardware according to what is specified.

Object Description

Index	2000h
Name	DI Pull Up Pull Down
Object Type	ARRAY
Data Type	UNSIGNED8

Entry Description

Sub-Index	0h
Description	Largest sub-index supported
Access	RO
PDO Mapping	No
Value Range	1
Default Value	1

Sub-Index	1h to 5h
Description	DI Pull Up Pull Down

Access	RW
PDO Mapping	No
Value Range	0 to 2
Default Value	2

3.4.2. Object 2002h: DI Latched 8-bit

This object defines the latched behavior of a group of 5 input lines. When active, an input logic level will change state as per Figure 5 in Section 1.2.2. If an input is latched, object 6002h, DI Polarity, is ignored. Input latching can be enabled individually.

1 = input latched 0 = input not latched

Object Description

Index	2002h
Name	DI Latched 8-bit
Object Type	ARRAY
Data Type	UNSIGNED8

Entry Description

Sub-Index	0h
Description	Largest sub-index supported
Access	RO
PDO Mapping	No
Value Range	1
Default Value	1

Sub-Index	1h
Description	DI1 to DI5 Latched
Access	RW
PDO Mapping	No
Value Range	1Fh (31) [0001 1111b]
Default Value	00h (0) [0000 0000b]

3.4.3. Object 2200h: DO Read Output 8-bit

This read-only object reflects the actual state of the output relays at any point for a group of 6 output lines. This object is mapped to TPDO1 by default.

1 = output ON 0 = output OFF

Object Description

Index	2200h
Name	DO Read Output 8-bit
Object Type	ARRAY
Data Type	UNSIGNED8

Entry Description

Sub-Index	0h
Description	Largest sub-index supported
Access	RO
PDO Mapping	No
Value Range	1
Default Value	1

Sub-Index	1h
Description	DO1 to DO6 Read Output
Access	RO
PDO Mapping	Yes
Value Range	3Fh (63) [0011 1111b]
Default Value	00h (0) [0000 0000b]

3.4.4. Object 2210h: DO Control Source

This object selects the source of the control signal which determines the logic for controlling each output. See Section 1.3.2 for more information about how this object is used in the control logic.

Object Description

Index	2210h
Name	DO Control Source
Object Type	ARRAY
Data Type	UNSIGNED8

Entry Description

Sub-Index	0h
Description	Largest sub-index supported
Access	RO
PDO Mapping	No
Value Range	6
Default Value	6

Sub-Index	1h to 6h
Description	DO1 to DO6 Control Source
Access	RW
PDO Mapping	NO
Value Range	0 to 6
Default Value	0 (CAN Control)

3.4.5. Object 2212h: DO Output Type

This objects defines the type of digital output, as defined in Table 7

Object Description

Index	2212h
Name	DO Output Type
Object Type	ARRAY
Data Type	UNSIGNED8

Entry Description

Sub-Index	0h
Description	Largest sub-index supported
Access	RO
PDO Mapping	No
Value Range	6
Default Value	6

Sub-Index	1h to 6h
Description	DO1 to DO6 Output Type
Access	RW
PDO Mapping	NO
Value Range	0 to 4
Default Value	1 (Digital Output)

3.4.6. Object 2230h: DO Output Frequency

This object sets the frequency of the output when a PWM or Pulsed output type is selected in object 2212h.

Object Description

Index	2230h
Name	DO Output Frequency
Object Type	ARRAY
Data Type	UNSIGNED8

Entry Description

Sub-Index	0h
Description	Largest sub-index supported
Access	RO
PDO Mapping	No
Value Range	6
Default Value	6

Sub-Index	1h to 6h
Description	DO1 to DO6 Output Frequency
Access	RW
PDO Mapping	NO
Value Range	0 to 200 (Hz)
Default Value	100 (Hz)

3.4.7. Object 2231h: DO Output Duty Cycle

This object sets the output duty cycle in percentage when a PWM output type is selected in object 2212h.

Object Description

Index	2231h
Name	DO Output Duty Cycle
Object Type	ARRAY
Data Type	UNSIGNED8

Entry Description

Sub-Index	0h
Description	Largest sub-index supported
Access	RO
PDO Mapping	No
Value Range	6
Default Value	6

Sub-Index	1h to 6h
Description	DO1 to DO6 Output Duty Cycle
Access	RW
PDO Mapping	NO
Value Range	0 to 100 (%)
Default Value	50 (%)

3.4.8. Object 2240h: DO Output Startup Delay

This object sets the start-up delay in milliseconds when a timed output type is selected in object 2212h.

Object Description

Index	2240h
Name	DO Output Startup Delay
Object Type	ARRAY
Data Type	UNSIGNED16

Entry Description

Sub-Index	0h
Description	Largest sub-index supported
Access	RO
PDO Mapping	No
Value Range	6
Default Value	6

Sub-Index	1h to 6h
Description	DO1 to DO6 Output Startup Delay
Access	RW
PDO Mapping	NO
Value Range	0 to 60000 (ms)
Default Value	1000 (ms)

3.4.9. Object 2241h: DO Output ON Time

This object sets the ON time in milliseconds when a timed output type is selected in object 2212h.

Object Description

Index	2241h
Name	DO Output ON Time
Object Type	ARRAY
Data Type	UNSIGNED16

Entry Description

Sub-Index	0h
Description	Largest sub-index supported
Access	RO
PDO Mapping	No
Value Range	6
Default Value	6

Sub-Index	1h to 6h
Description	DO1 to DO6 Output ON Time
Access	RW
PDO Mapping	NO
Value Range	0 to 60000 (ms)
Default Value	1000 (ms)

3.4.10. Object 2242h: DO Output Timer Repeat

This object is used to repeat the ON and OFF timer when timed output is selected for object 2212h. If this object is set to 1 then the timer will repeat staying ON for the set value in object 2241h and OFF for the set value in object 2243.

Object Description

Index	2242h
Name	DO Output Timer Repeat
Object Type	ARRAY
Data Type	UNSIGNED8

Entry Description

Sub-Index	0h
Description	Largest sub-index supported
Access	RO
PDO Mapping	No
Value Range	6
Default Value	6

Sub-Index	1h to 6h
Description	DO1 to DO6 Output Timer Repeat
Access	RW
PDO Mapping	NO
Value Range	0 or 1
Default Value	1

3.4.11. Object 2243h: DO Output OFF Time

This object sets the OFF time in milliseconds when a timed output type is selected in object 2212h and timer repeat object is set in object 2242h.

Object Description

Index	2243h
Name	DO Output OFF Time
Object Type	ARRAY
Data Type	UNSIGNED16

Entry Description

Sub-Index	0h
Description	Largest sub-index supported
Access	RO
PDO Mapping	No
Value Range	6
Default Value	6

Sub-Index	1h to 6h
Description	DO1 to DO6 Output OFF Time
Access	RW
PDO Mapping	NO
Value Range	0 to 60000 (ms)
Default Value	1000 (ms)

3.4.12. Object 2250h: DO Output Current Feedback

This object contains the output current feedback measured by the unit. This object is mapped to TPDO1.

Object Description

Index	2250h
Name	DO Output Current Feedback
Object Type	ARRAY
Data Type	UNSIGNED8

Entry Description

Sub-Index	0h
Description	Largest sub-index supported
Access	RO
PDO Mapping	No
Value Range	6
Default Value	6

Sub-Index	1h to 6h
Description	DO1 to DO6 Current Feedback
Access	RO
PDO Mapping	YES
Value Range	UNSIGNED8
Default Value	No

3.4.13. Object 2400h: AI Input Type

This objects defines the type of inputs, as defined in Table 1

Object Description

Index	2400h
Name	AI Input Type
Object Type	ARRAY
Data Type	UNSIGNED8

Entry Description

Sub-Index	0h
Description	Largest sub-index supported
Access	RO
PDO Mapping	No
Value Range	5
Default Value	5

Sub-Index	1h to 5h
Description	AI1 to AI5 Input Type
Access	RW
PDO Mapping	No
Value Range	0 to 5
Default Value	3

3.4.14. Object 2410h: AI Input Range

This object defines the input range for the input type selected in object 2400h. Depending on the input type, the input range may not be selectable.

Object Description

Index	2410h
Name	AI Input Range
Object Type	ARRAY
Data Type	UNSIGNED8

Entry Description

Sub-Index	0h
Description	Largest sub-index supported
Access	RO
PDO Mapping	No
Value Range	5
Default Value	5

Sub-Index	1h to 2h	
Description	AI1 to AI2 Input Range	
Access	RW	
PDO Mapping	No	
Value Range	Input Type	Range
	Voltage	0: 0-5V
	Current	0: 0-20mA
		1: 4-20mA
	Digital	0: ON-OFF
	Frequency	0: 0.5Hz to 50Hz
1: 10Hz to 1KHz		
2: 100Hz to 10KHz		
PWM	0: 10Hz to 1KHz	
	1: 100Hz to 10KHz	
Default Value	0	

Sub-Index	3h to 5h	
Description	AI3 to AI5 Input Range	
Access	RW	
PDO Mapping	No	
Value Range	Input Type	Range
	Digital	0: ON-OFF
	Frequency	0: 0.5Hz to 50Hz
		1: 10Hz to 1KHz
		2: 100Hz to 10KHz
PWM	0: 10Hz to 1KHz	
	1: 100Hz to 10KHz	
Default Value	0	

Object 2420h: AI Minimum

This object defines the minimum value of the input type.

Object Description

Index	2420h
Name	AI Minimum
Object Type	ARRAY
Data Type	INTEGER16

Entry Description

Sub-Index	0h
Description	Largest sub-index supported
Access	RO
PDO Mapping	No
Value Range	5
Default Value	5

Sub-Index	1h to 2h	
Description	AI1 to AI2 Input Minimum	
Access	RW	
PDO Mapping	No	
Value Range	Input Type	Minimum
	Voltage	0mV
	Current	0mA or 4mA
	Digital	0
	Frequency	0.5Hz or 10Hz or 100Hz
	PWM	0%
Default Value	500 (mV)	

Sub-Index	3h to 5h	
Description	AI3 to AI5 Input Minimum	
Access	RW	
PDO Mapping	No	
Value Range	Input Type	Minimum
	Digital	0
	Frequency	0.5Hz or 10Hz or 100Hz
	PWM	0%
Default Value	0	

3.4.15. Object 2421h: AI Maximum

This object defines the maximum value of the input type.

Object Description

Index	2421h
Name	AI Maximum
Object Type	ARRAY
Data Type	INTEGER16

Entry Description

Sub-Index	0h
Description	Largest sub-index supported
Access	RO
PDO Mapping	No
Value Range	5
Default Value	5

Sub-Index	1h to 2h	
Description	AI1 to AI2 Input Maximum	
Access	RW	
PDO Mapping	No	
Value Range	Input Type	Maximum
	Voltage	5000mV
	Current	20mA
	Digital	1
	Frequency	50Hz or 1KHz or 10KHz
	PWM	100%
Default Value	4500 (mV)	

Sub-Index	3h to 5h	
Description	AI3 to AI5 Input Maximum	
Access	RW	
PDO Mapping	No	
Value Range	Input Type	Maximum
	Digital	1
	Frequency	50Hz or 1KHz or 10KHz
	PWM	100%
Default Value	1	

3.4.16. Object 2430h: AI Decimal Digits

This object describes the number of digits following the decimal point (i.e. resolution) of the input type. For example if this object is set to 3, a 1V measured value of an input will be shown as 1000.

Object Description

Index	2430h
Name	AI Decimal Digits
Object Type	ARRAY
Data Type	UNSIGNED8

Entry Description

Sub-Index	0h
Description	Largest sub-index supported
Access	RO
PDO Mapping	No
Value Range	5
Default Value	5

Sub-Index	1h to 2h
Description	AI1 to AI2 Decimal Digit
Access	RW
PDO Mapping	No
Value Range	0 to 4
Default Value	3 (0.001) (mV)

Sub-Index	3h to 5h
Description	AI3 to AI5 Decimal Digit
Access	RW
PDO Mapping	No
Value Range	0 to 4
Default Value	0

3.4.17. Object 2440h: AI Filter Type

This object defines the type of data filter that will be applied to the raw input data, as read from the ADC or Timer. The types of data filters are defined in Table 4, and how they are used is outlined in Section 1.2.1.

Object Description

Index	2440h
Name	AI Filter Type
Object Type	ARRAY
Data Type	UNSIGNED8

Entry Description

Sub-Index	0h
Description	Largest sub-index supported
Access	RO
PDO Mapping	No
Value Range	5
Default Value	5

Sub-Index	1h to 5h
Description	AI1 to AI5 Filter Type
Access	RW
PDO Mapping	No
Value Range	0 to 2
Default Value	0

3.4.18. Object 2441h: AI Filter Constant

This object defines the number of steps used in the various filters, as defined in Section 1.2.1

Object Description

Index	2441h
Name	AI Filter Constant
Object Type	ARRAY
Data Type	UNSIGNED8

Entry Description

Sub-Index	0h
Description	Largest sub-index supported
Access	RO
PDO Mapping	No
Value Range	5
Default Value	5

Sub-Index	1h to 5h
Description	AI1 to AI5 Filter Constant
Access	RW
PDO Mapping	No
Value Range	1 to 1000
Default Value	10

3.4.19. Object 2600h: ADC Filter Frequency

This object determines the filter frequency of the processor's analog-to-digital converter. The options for the filter are listed in Table 3 in Section 1.2.1.

Object Description

Index	2600h
Name	ADC Filter Frequency
Object Type	VAR
Data Type	UNSIGNED8

Entry Description

Sub-Index	0h
Description	ADC Filter Frequency
Access	RW
PDO Mapping	No
Value Range	0 to 3
Default Value	1

3.4.20. Object 2601h: Power Supply Under Voltage

This value specifies the lower limit of the expected power supply range. A Vps measurement below this value will result in a negative overload. This object is scaled with a fixed resolution of 1 decimal digit, or 0.1V.

Object Description

Index	2601h
Name	Power Supply Under Voltage
Object Type	VAR
Data Type	UNSIGNED8

Entry Description

Sub-Index	0h
Description	Power Supply Under Voltage
Access	RW
PDO Mapping	No
Value Range	90(*0.1V) to Object 2602h
Default Value	100 (which represents 10V)

3.4.21. Object 2602h: Power Supply Over Voltage

This value specifies the upper limit of the expected power supply range. A Vps measurement above this value will result in a positive overload. This object is scaled with a fixed resolution of 1 decimal digit, or 0.1V.

Object Description

Index	2602h
Name	Power Supply Over Voltage
Object Type	VAR
Data Type	UNSIGNED8

Entry Description

Sub-Index	0h
Description	Power Supply Over Voltage
Access	RW
PDO Mapping	No
Value Range	Object 2601h to 360(*0.1V)
Default Value	340 (which represents 34V)

3.4.22. Object 2651h: Error Reaction Delay

This object is used to filter out spurious signals and to prevent saturating the CANopen® network with broadcasts of object 1003h as faults are set/cleared. Before an Analog Input, Digital Output, Vps or lost communication fault is recognized (i.e. the EMCY code is added to the pre-defined error field list), it must remain active throughout the period of time defined in this object. The physical unit for this object is milliseconds.

Object Description

Index	2651h
Name	Error Reaction Delay
Object Type	ARRAY
Data Type	UNSIGNED8

Entry Description

Sub-Index	0h
Description	Largest sub-index supported
Access	RO
PDO Mapping	No
Value Range	4
Default Value	4

Sub-Index	1h
Description	Analog Input Error Reaction Delay
Access	RW
PDO Mapping	No
Value Range	0 to 60000 (ms)
Default Value	1000 (ms)

Sub-Index	2h
Description	Digital Output Error Reaction Delay
Access	RW
PDO Mapping	No
Value Range	0 to 60000 (ms)
Default Value	1000 (ms)

Sub-Index	3h
Description	Supply Voltage Error Reaction Delay
Access	RW
PDO Mapping	No
Value Range	0 to 60000 (ms)
Default Value	1000 (ms)

Sub-Index	4h
Description	Communication Error Reaction Delay
Access	RW
PDO Mapping	No
Value Range	0 to 60000 (ms)
Default Value	1000 (ms)

3.4.23. Object 2652h: Error Reaction Delay

This object is used to prevent rapid activation/clearing of a fault flag, and sending of object 1003h to the CANopen® network. Once the error has gone above/below the thresholds, it must come back into range minus/plus this value to clear the fault. This object is scaled with a fixed resolution of 1 decimal digit, or 0.1V.

Object Description

Index	2652h
Name	Error Delay Hysteresis
Object Type	ARRAY
Data Type	UNSIGNED8

Entry Description

Sub-Index	0h
Description	Largest sub-index supported
Access	RO
PDO Mapping	No
Value Range	4
Default Value	4

Sub-Index	1h
Description	Analog Input Error Delay Hysteresis
Access	RW
PDO Mapping	No
Value Range	0 to 5000 (mV) 0 to 20 (mA)
Default Value	500 (mV)

Sub-Index	2h
Description	Digital Output Error Delay Hysteresis
Access	RW
PDO Mapping	No
Value Range	100 to 5000 (mA)
Default Value	100 (mA)

Sub-Index	3h
Description	Supply Voltage Error Delay Hysteresis
Access	RW
PDO Mapping	No
Value Range	0 to 50 (*0.1V)
Default Value	15 (*0.1V)

Sub-Index	4h
Description	Communication Error Delay Hysteresis
Access	RO
PDO Mapping	No
Value Range	TRUE
Default Value	TRUE

3.4.24. Object 5020h: Power Supply Over Voltage

This read-only object is available for diagnostic feedback purposes. It reflects the measured voltage powering the controller. The physical unit for this object is volts.

Object Description

Index	5020h
Name	Power Supply Voltage
Object Type	VAR
Data Type	UNSIGNED8

Entry Description

Sub-Index	0h
Description	Power Supply Voltage
Access	RO
PDO Mapping	No
Value Range	FLOAT32
Default Value	No

3.4.25. Object 5555h: Start in Operational Mode

This object allows the unit to start in Operational mode without requiring the presence of a CANopen® Master on the network. It is intended to be used only when running the AX021301 controller as a stand-alone module. This should always be set FALSE whenever it is connected to a standard master/slave network.

Object Description

Index	5555h
Name	Start in Operational Mode
Object Type	VARIABLE
Data Type	UNSIGNED8

Entry Description

Sub-Index	0h
Access	RW
PDO Mapping	No
Value Range	0 (FALSE) or 1 (TRUE)
Default Value	0 [FALSE]

APPENDIX A – Technical Specifications

Specifications are indicative and subject to change. Actual performance will vary depending on the application and operating conditions. Users should satisfy themselves that the product is suitable for use in the intended application. All our products carry a limited warranty against defects in material and workmanship. Please refer to our Warranty, Application Approvals/Limitations and Return Materials Process as described on <https://www.axiomatic.com/service/>.

Inputs

Power Supply Input - Nominal	12 or 24VDC nominal (9...36 VDC power supply range) Surge protection is provided. NB. The max. total current draw on the power supply input pins is 7 A @ 24VDC, at one time.
Reverse Polarity Protection	Provided
Analog Inputs	2 inputs (Refer to Table 1.0 and Table 2.0. in this section) Inputs are user selectable. <ul style="list-style-type: none"> • Analog (0-5V, 0-20mA or 4-20mA) • PWM (up to 5kHz, 0-100% D.C.) • Frequency • Digital (Active High)
Analog GND	Analog GND connections are provided.
Digital Inputs	3 inputs (Refer to Table 1.0 and Table 2.0.) Inputs are user selectable. <ul style="list-style-type: none"> • Digital (Active High or Active Low) • PWM (up to 5kHz, 0-100% D.C.) • Frequency
Digital GND	A digital GND is provided.

Table 1.0 Selection of Inputs to AX021301

Input Type	Description
# of Inputs	There are a total of 5 input channels available, which are user selectable from a variety of input types
Disable Inputs	Each input can be configured as a disable input command. When disable is selected, no CAN messages associated with that channel are sent to the network.
Analog Inputs	Up to 2 analog inputs are available. 0...5VDC 4...20mA or 0...20mA
Digital Inputs	Up to 5 active high, digital inputs is user selectable. Up to 2 active low, digital inputs is user selectable. Active High - The input is configured to read the state of the input (switch is connected to a +V signal when ON). Active Low – The input is configured to read the state of the input (switch is connected to a GND signal when ON).
PWM Signal Inputs	Up to 5 PWM inputs are available to interface to a PWM signal from an ECM, PLC or other. PWM Signal Frequency: up to 6kHz Amplitude: 5-12V PWM Duty Cycle: 0 to 100%
Pulse Inputs	Up to 5 pulse (Frequency) inputs are available.

Table 2.0 - Absolute Maximums for Inputs

	Min	Max	Units	Comments
Power Supply	9	36	V dc	➤ Reverse Polarity and Surge protection is provided. ➤ Software, under and over voltage security features.
Analog Input Voltage	0.05	36	Vdc	
Analog Input Current	0	21	mA	
PWM Input Frequency	50	6000	Hz	➤ 200 =< Freq <= 1000 Hz recommended for better accuracy
PWM duty cycle Input	0	100	%	
Input Frequency	10	65000	Hz	
Digital Input Voltage	4	36	Vdc	

Table 3.0 - Input Accuracy

Input Type	Accuracy
0 – 5 VDC	+/- 1 % of actual input voltage
0 (4) – 20 mA	100 %
PWM	+/- 0.1 % duty cycle
Frequency	+/- 0.15 % of actual input frequency

Outputs

Output Type	<p>6 outputs are user selectable from the following.</p> <ul style="list-style-type: none"> • Digital • Timed • Pulsed • PWM <p>The output response is user selectable from the following.</p> <ul style="list-style-type: none"> • Disabled • Normal On/Off • Inverted On/Off
Digital Output	<p>High Side (sourcing) Drives up to 6 On/Off Valves (up to 5A each) The output toggles between OFF and ON states based on the states of the control logic.</p> <p>NB. The maximum total current draw permitted on the power supply input pins is 6 Amps @ 24VDC, at one time.</p>
Pulsed Output	<p>The pulsed output type is controlled by a digital ON-OFF state. However, unlike a digital output, when a pulsed output logic state is ON, the output will be turned on/off at the frequency set in object 2230h DO Output Frequency, with the duty cycle set in object 2231 DO Duty Cycle.</p>
Timed Output	<p>The pulsed output type is controlled by a digital ON-OFF state. However, unlike a digital output, when a timed output logic state comes ON, the output will be turned ON after the value in object 2240h DO Start Up Delay has elapsed. The output will stay ON for the time set in object 2241h DO ON Time, then shut off (even though the logic state is still ON). If object 2242h DO Timer Repeat is TRUE, then the output will be OFF for the time set in object 2243h DO OFF Time before coming back ON. The ON/OFF cycle will continue while the output logic state is still ON.</p>
PWM Output	<p>For this output type, the output will be switched at the frequency in object 2230h DO Output Frequency. The duty cycle is fixed at minimum 0% and maximum 100%. The output PWM will be proportional to the input measured. The PWM output is linearly defined by the input minimum and maximum set in objects 2420h and 2421h.</p>
Overcurrent and Short Circuit Protection	Provided
Output Voltage Regulation	93 % of Supply voltage when all 6 outputs are ON (Refer to Figure below.)

Output Volt Percentage vs. Number Of Outputs ON

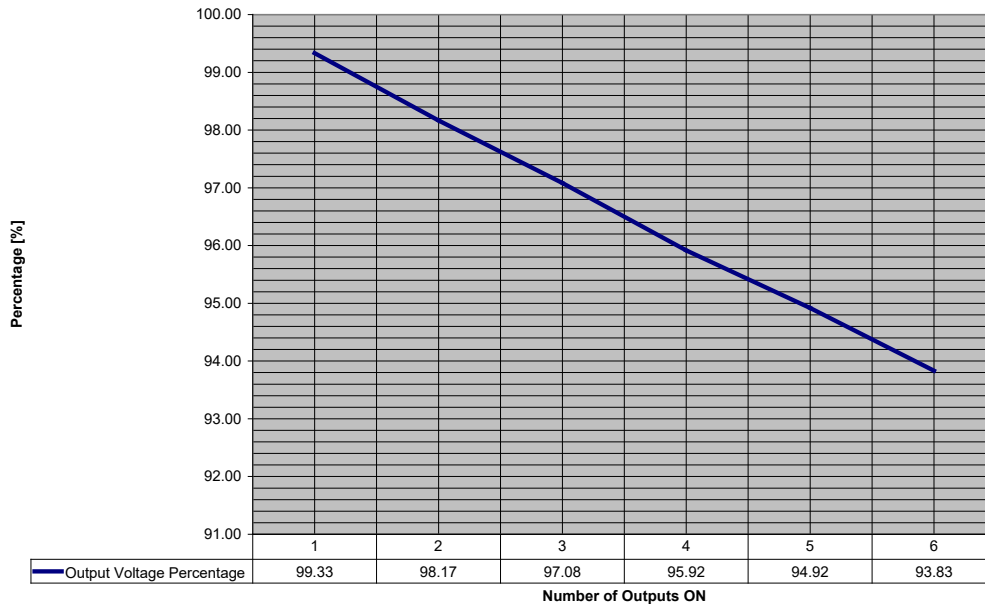

% Output Voltage vs. No. of Outputs ON

General Specifications

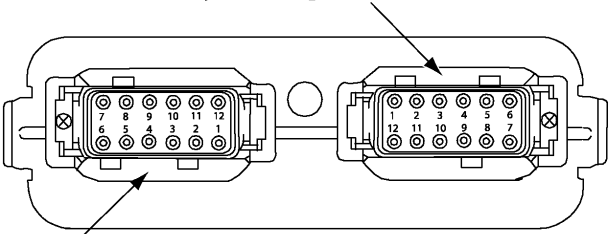
Microprocessor	DSP56F8346
Control Logic	Standard control logic
Communications	1 CAN port (CANopen®) Compliant with the CiA standard CiA DS-401 V3.0 – <i>CANopen® device profile for Generic I/O modules</i> (CAN in Automation 2008) 1 RS-232 port
User Interface	EDS File is provided. The controller architecture consists of a set of internal functional blocks, which can be programmed and arbitrarily connected together to achieve the required system functionality application. All objects are user configurable using standard commercially available tools that work with a CANopen® Object Dictionary via an .EDS file.
Network Termination	It is necessary to terminate the network with external termination resistors. The resistors are 120 Ohm, 0.25W minimum, metal film or similar type. They are placed between CAN_H and CAN_L terminals at both ends of the network.
Diagnostics	Current draw from the solenoid(s) is read by the microprocessor and stored in memory.
Electrical Connections	24-pin receptacle (equivalent TE Deutsch P/N: DTM13-12PA-12PB-R008) Mating plug: Deutsch DTM06-12SA and DTM06-12SB with 2 wedgelocks (WM12S) and 24 contacts (1062-20-0122) that accept 18 AWG wire. Use dielectric grease on the pins when installing the controller. Key Arrangement B (black)  Key Arrangement A (grey) FRONT VIEW 24 PIN RECEPTACLE
Enclosure and Dimensions	High Temperature Nylon PCB Enclosure - (equivalent TE Deutsch P/N: EEC-325X4B) 4.62 x 5.24 x 1.43 inches 117.42 x 133.09 x 36.36 mm (W x L x H excluding mating plugs) <i>For dimensional drawing refer to Section 1.6.</i>
Weight	0.55 lbs. (0.25 kg)
Operating Conditions	-40 to 85°C (-40 to 185°F)
Protection	IP67, Unit is conformally coated in the housing. Plugs carry an IP69 rating.

OUR PRODUCTS

AC/DC Power Supplies
Actuator Controls/Interfaces
Automotive Ethernet Interfaces
Battery Chargers
CAN Controls, Routers, Repeaters
CAN/WiFi, CAN/Bluetooth, Routers
Current/Voltage/PWM Converters
DC/DC Power Converters
Engine Temperature Scanners
Ethernet/CAN Converters,
Gateways, Switches
Fan Drive Controllers
Gateways, CAN/Modbus, RS-232
Gyroscopes, Inclinometers
Hydraulic Valve Controllers
Inclinometers, Triaxial
I/O Controls
LVDT Signal Converters
Machine Controls
Modbus, RS-422, RS-485 Controls
Motor Controls, Inverters
Power Supplies, DC/DC, AC/DC
PWM Signal Converters/Isolators
Resolver Signal Conditioners
Service Tools
Signal Conditioners, Converters
Strain Gauge CAN Controls
Surge Suppressors

OUR COMPANY

Axiomatic provides electronic machine control components to the off-highway, commercial vehicle, electric vehicle, power generator set, material handling, renewable energy and industrial OEM markets. ***We innovate with engineered and off-the-shelf machine controls that add value for our customers.***

QUALITY DESIGN AND MANUFACTURING

We have an ISO9001:2015 registered design/manufacturing facility in Canada.

WARRANTY, APPLICATION APPROVALS/LIMITATIONS

Axiomatic Technologies Corporation reserves the right to make corrections, modifications, enhancements, improvements, and other changes to its products and services at any time and to discontinue any product or service without notice. Customers should obtain the latest relevant information before placing orders and should verify that such information is current and complete. Users should satisfy themselves that the product is suitable for use in the intended application. All our products carry a limited warranty against defects in material and workmanship. Please refer to our Warranty, Application Approvals/Limitations and Return Materials Process at <https://www.axiomatic.com/service/>.

COMPLIANCE

Product compliance details can be found in the product literature and/or on axiomatic.com. Any inquiries should be sent to sales@axiomatic.com.

SAFE USE

All products should be serviced by Axiomatic. Do not open the product and perform the service yourself.



This product can expose you to chemicals which are known in the State of California, USA to cause cancer and reproductive harm. For more information go to www.P65Warnings.ca.gov.

SERVICE

All products to be returned to Axiomatic require a Return Materials Authorization Number (RMA#) from sales@axiomatic.com. Please provide the following information when requesting an RMA number:

- Serial number, part number
- Runtime hours, description of problem
- Wiring set up diagram, application and other comments as needed

DISPOSAL

Axiomatic products are electronic waste. Please follow your local environmental waste and recycling laws, regulations and policies for safe disposal or recycling of electronic waste.

CONTACTS

Axiomatic Technologies Corporation
1445 Courtneypark Drive E.
Mississauga, ON
CANADA L5T 2E3
TEL: +1 905 602 9270
FAX: +1 905 602 9279
www.axiomatic.com
sales@axiomatic.com

Axiomatic Technologies Oy
Höytämöntie 6
33880 Lempäälä
FINLAND
TEL: +358 103 375 750
www.axiomatic.com
salesfinland@axiomatic.com