

LVDT Simulator

Part No.: LVDT-DR-04

Description: The LVDT Simulator is used to test LVDT or RVDT sensors. Using a 0-10VDC command signal input and an excitation (drive input), the unit provides two simulation outputs of 1-5VAC. An internal 3kHz oscillator can be utilized as an alternative excitation source. Both outputs are fully isolated. The unit accepts power supply input from 4 to 32VDC. When the input voltage increases from 0-10VDC, the output voltage A increases from 1 to 5VAC and the output voltage B decreases from 5 to 1VAC. Factory settings for the offset (minimum) and span (maximum) are user adjustable. A LED indicates power is OK. The unit is conformal coated and available in a DIN rail mount housing.

BLOCK DIAGRAM

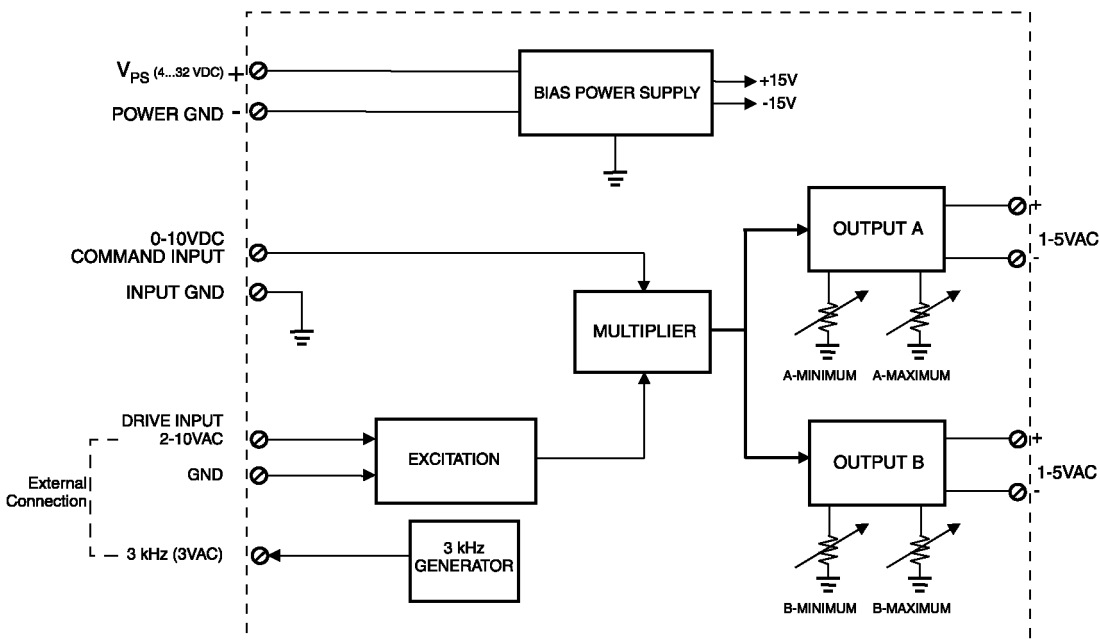

Technical Specifications: Typical at nominal input voltage and 25 degrees C unless otherwise specified.

Specifications are indicative and subject to change. Actual performance will vary depending on the application and operating conditions. Users should satisfy themselves that the product is suitable for use in the intended application. All our products carry a limited warranty against defects in material and workmanship. Please refer to our Warranty, Application Approvals/Limitations and Return Materials Process as described on <https://www.axiomatic.com/service/>.

Ordering Part Number:	Axiomatic P/N: LVDTs-DR-04
Power Supply:	
Power Supply	4-32VDC
Isolation	Provided
Reverse Polarity Protection	Provided
Input:	
Command Signal	0-10VDC
Input Impedance	1 MOhm
Protection	+/-100V
Input Bias	+5V
Input Common	Grounded
Drive Input: An external excitation input of 2-10VAC can be provided. Alternatively, the internal 3kHz oscillator can be utilized by connecting terminal 3 to drive input terminal 2.	
Nominal Input Voltage	5VAC
Frequency	3 kHz
Input Voltage Range	2-10VAC
Input Common	Grounded
Input Impedance	300 kOhm
Input Protection	50VAC
Simulation Output:	
Isolation	Total isolation provided
Output A Level	1VAC@Vin = 0V 5VAC@Vin = 10V
Output B Level	5VAC@ Vin = 0V 1VAC@Vin = 10V
Settling Time	Rising edge command: 30 mSec Falling edge command: 30 mSec Measured over a full-scale change in command input (Δ 10V) NB. For command input changes less than full-scale, the settling times are less.
Load Effect	<1% with 10kOhm
Protection	Short Circuit Protected
Drive Input Effect	<0.2% @2 to 10VAC
Distortion THD	<1%

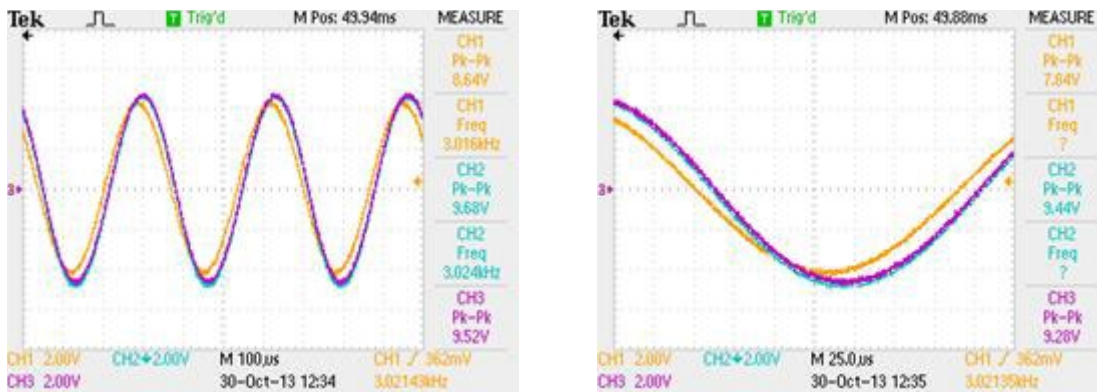
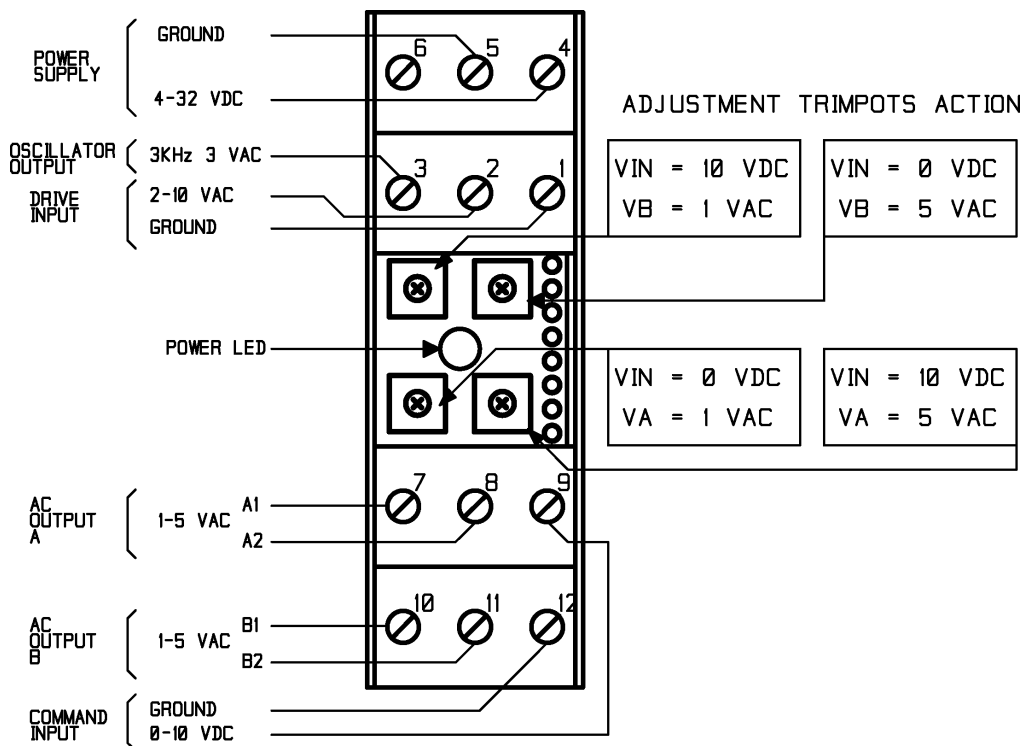

Figure 1.0 - Phase relationship between input and output signals (10 degrees)

Oscillator Output:	
Frequency	3kHz +/-5%
Voltage	3VAC +/-5%
Protection	Provided
Distortion THD	<1%
Load	10K Minimum

General Specifications:	
LED Indication	Power OK – LED ON
Protection	Circuit boards are conformal coated. IP40 rated housing, Terminals rated at IP20
Operating Conditions	-40 to 85 degrees C (-40 to 185 degrees F)
Electrical connection	Screw terminals accept 14-24 AWG wire
Weight	0.25 lbs. (0.11 kg)
Packaging and Dimensions (W x H x D)	DR12, DIN rail mount (35 mm) 16 Amp max. current rating Polycarbonate 75 x 98.5 x 22.5 mm (W x H x D) 2.95 x 3.87 x 0.88 inches

Adjustments:	
Offset (Minimum) Span (Maximum)	Remove plastic cover to access single turn trim pots. With 0VDC command input, confirm B-Maximum is set to 5VAC and A-Minimum to 1VAC. With 10VDC command input, confirm B-Minimum is set to 1VAC and A-Maximum to 5VAC.



Form: TDLVDTSDR04-06/27/23