

TECHNICAL DATASHEET #TDAX181001
TC/Analog Inputs to CAN Controller
 4 Thermocouple, 7 Analog & 3 Signal Inputs
 12 Vdc, 24 Vdc, 48 Vdc
 2 CANopen®

P/N: AX181001

Description:

The TC/Analog Inputs to CAN Controller receives inputs from engine coolant, fuel and differential pressure sensors, engine temperature sensors, thermistors as well as thermocouples and is networked to a CAN based control system. Seven +5V references (10 mA) are provided to power the sensors. The 2 CANopen® ports are isolated from signal inputs and thermocouple inputs.

Using standard CANopen® tools, the user can select the desired inputs from the following signal options.

- 4 Thermocouples (Type J, K or T)
- 7 Analog Signals (0-5 V, 0-10V, 0-20 mA, 4-20 mA)
- 3 Universal Signal Inputs (0-5V, 0-10V, Thermistor, 0-20 mA, 4-20 mA, PWM, Frequency or Counter, Discrete)

A rugged power supply interface accepts 12 Vdc, 24 Vdc or 48 Vdc nominal for battery powered machine applications. The unit carries an IP67 rating. It carries a CE mark. The rugged enclosure with four 12-pin connectors (which are TE Deutsch equivalents) is suitable for diesel engine environments. It operates from -40 to 85°C (-40 to 185°F).



Applications:

- Power Gen Set Engine Control Systems
- Oil and Gas Equipment Automation
- Marine Engine Applications
- Off-highway Machine Automation

Ordering Part Numbers:

AX181001	CANopen®
AX181000	SAEJ1939

EDS File

Mating Plug Kit: **AX070123**

Technical Specifications:

Specifications are indicative and subject to change. Actual performance will vary depending on the application and operating conditions. Users should satisfy themselves that the product is suitable for use in the intended application. All our products carry a limited warranty against defects in material and workmanship. Please refer to our Warranty, Application Approvals/Limitations and Return Materials Process as described on <https://www.axiomatic.com/service/>.

Block Diagram

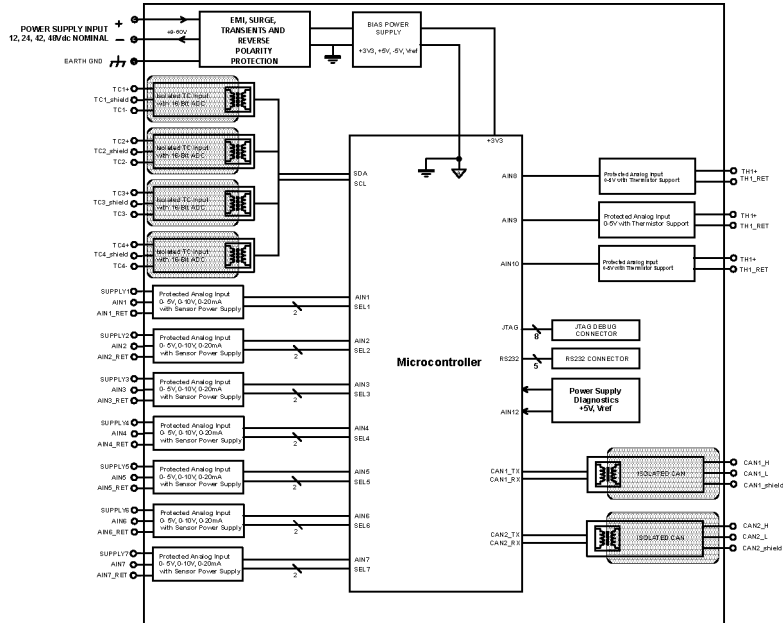

Inputs

Power Supply Input	12 Vdc, 24 Vdc or 48 Vdc nominal (9...60 Vdc power supply range)
Protection	Reverse polarity protection Overvoltage protection is up to 120 V.
Inputs	4 Thermocouple Inputs 7 Analog Signal Inputs (0-5 V, 0-10V, 0-20 mA, 4-20 mA) 3 Universal Signal Inputs (0-5V, 0-10V, Thermistor, 0-20 mA, 4-20 mA, PWM, Frequency or Counter, Discrete) User programmable (Refer to Table 1.0.) Inputs and Power are isolated from CAN.
Inputs Scan Rate	Each analog and universal input is scanned every 1 ms. A complete scan of all inputs is 10 ms. New measured values are ready every 10 ms. The 4 TC inputs new measured value is available every 400 ms.
Analog Grounds	10 are provided and they are common to each other.

Table 1.0 – Inputs – User Programmable Options																									
Thermocouple Inputs	Reads up to 4 Type J, K or T thermocouple inputs <ul style="list-style-type: none"> • Full channel to channel isolation and isolation from CAN line, other inputs and power supply • Cold junction compensation is provided. • Thermocouple input resolution is 0.1 °C. • Accuracy is +/-1 °C throughout the entire range of the thermocouple input. • 4 shield connections are provided. • The sample rate for the 4 Channels is 300 ms. 																								
Analog Input Functions	Voltage or Current Input																								
Voltage Input	0-5 V (Impedance 200 KOhm) 0-10V (Impedance 150 KOhm)																								
Current Input	0-20 mA (Impedance 125 Ohm) 4-20 mA (Impedance 125 Ohm)																								
Digital Input Functions	Discrete Input, PWM Input, Frequency Input																								
Digital Input Level	12V or 24V Threshold: Low <1.5 V High >3.5V																								
PWM Input	0 to 100% 100 Hz to 10 kHz Note: Universal Inputs 2 and 3 share a timer in Frequency and PWM mode, thus they should be set on same frequency range.																								
Frequency/RPM Input	0.5 Hz to 50 Hz; 10 Hz to 1 kHz; or 100 Hz to 10 kHz																								
Digital Input	Active High with pull-up (input 8 - 5kΩ, input 9 and input 10 – 1kΩ)																								
Input Accuracy	<table border="1"> <thead> <tr> <th>Input Type</th> <th>Input Range</th> <th>Accuracy</th> </tr> </thead> <tbody> <tr> <td rowspan="2">Voltage</td> <td>0-5V</td> <td>0.1%</td> </tr> <tr> <td>0-10V</td> <td>0.1%</td> </tr> <tr> <td rowspan="2">Current</td> <td>0(4)-20mA</td> <td>0.1%</td> </tr> <tr> <td>Frequency</td> <td>0.5Hz-50Hz</td> <td>0.2%</td> </tr> <tr> <td rowspan="2"></td> <td>10Hz-1kHz</td> <td>0.17%</td> </tr> <tr> <td>100Hz-10kHz</td> <td>0.17%</td> </tr> <tr> <td rowspan="2">PWM</td> <td>Low Frequency</td> <td>0.08%</td> </tr> <tr> <td>High Frequency</td> <td>0.41%</td> </tr> </tbody> </table> <p style="text-align: center;">Table 2.0 - Input accuracy</p>	Input Type	Input Range	Accuracy	Voltage	0-5V	0.1%	0-10V	0.1%	Current	0(4)-20mA	0.1%	Frequency	0.5Hz-50Hz	0.2%		10Hz-1kHz	0.17%	100Hz-10kHz	0.17%	PWM	Low Frequency	0.08%	High Frequency	0.41%
Input Type	Input Range	Accuracy																							
Voltage	0-5V	0.1%																							
	0-10V	0.1%																							
Current	0(4)-20mA	0.1%																							
	Frequency	0.5Hz-50Hz	0.2%																						
	10Hz-1kHz	0.17%																							
	100Hz-10kHz	0.17%																							
PWM	Low Frequency	0.08%																							
	High Frequency	0.41%																							
Input Resolution	12-bit																								

Outputs

Reference Voltages	7 provided +5V +/- 0.5% (10 mA)
--------------------	------------------------------------

General Specifications

Microprocessor	STM32F205 32-bit, 512 kByte flash memory
Typical Quiescent Current	84 mA@12Vdc; 52 mA@24Vdc
Response Time	3 mSec.
Control Logic	Standard embedded software is provided.
Communications	2 Isolated CANopen® ports 300 Vrms

User Interface	EDS File Standard CANopen® tools (not supplied)
Operating Conditions	-40 to 85 °C (-40 to 185 °F)
Storage Temperature	-55 to 125 °C (-67 to 257°F)
Protection	IP67
Vibration	Random Vibration: 7.68 Grms peak Sinusoidal Component: 10 g peak Based on MIL-STD-202G, Methods 204G, 214A and 213B
Compliance	CE marking
Weight	1.30 lbs. (0.59 kg)
Enclosure	High Temperature Nylon Enclosure – (equivalent TE Deutsch P/N: EEC-5X650B) 4.03 x 4.25 x 1.68 inches 102.44 x 107.96 x 42.67 mm (L x W x H including integral connector) Refer to the dimensional drawing.
Electrical Connections	48-pin connector (equivalent TE Deutsch P/N: DT13-48PABCD-R015) or 48 pin Amphenol Face Plate Connector (P/N: ATM13-12PA-12PB-BM03), based on availability. Mates with the following TE Deutsch P/N equivalents: DT06-12SA Plug, DT 12 Way A Key DT06-12SB Plug, DT 12 Way B Key DT06-12SC Plug, DT 12 Way C Key DT06-12SD Plug, DT 12 Way D Key For the electrical pin out, refer to Table 3.0.
Network Termination	It is necessary to terminate the network with external termination resistors. The resistors are 120 Ohm, 0.25W minimum, metal film or similar type. They should be placed between CAN_H and CAN_L terminals at both ends of the network.

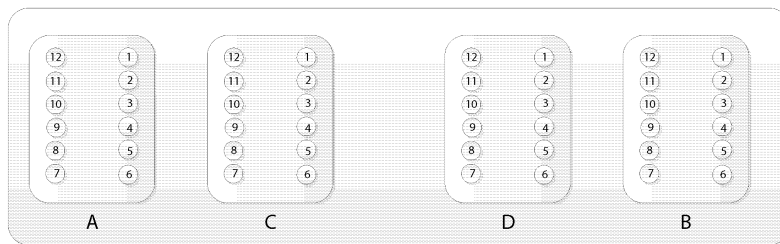
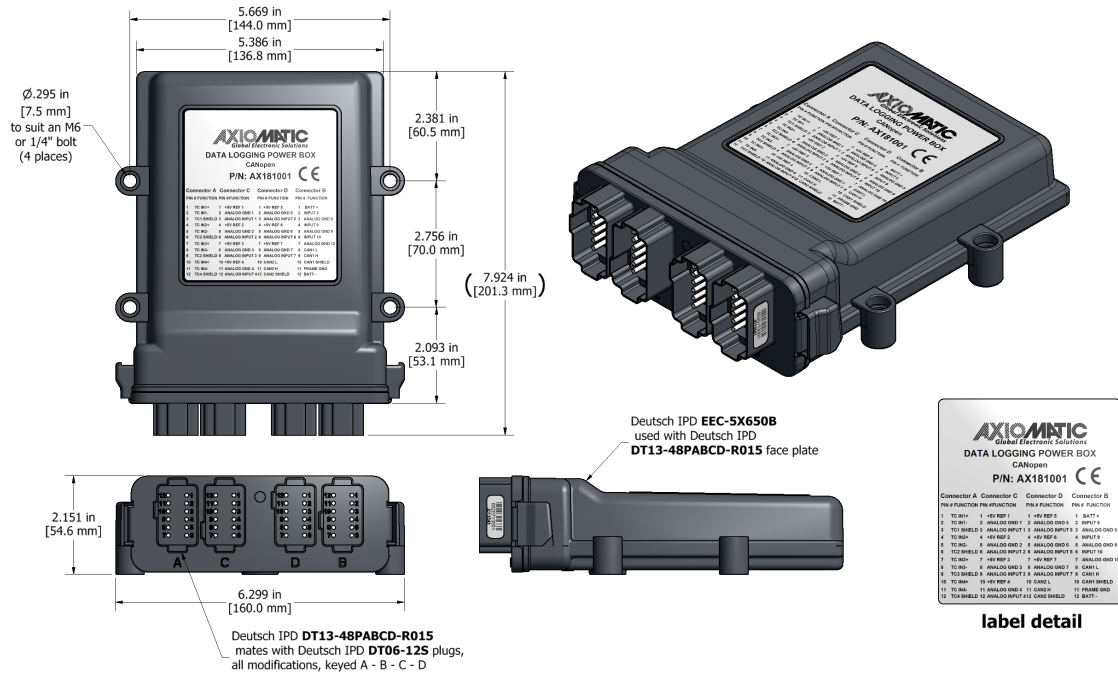

Table 3.0 - Electrical Pin Out

Connector A		Connector C		Connector D		Connector B	
Pin #	Function	Pin #	Function	Pin #	Function	Pin #	Function
1	TC IN1+	1	+5Vref. 1	1	+5Vref. 5	1	Batt+
2	TC IN1-	2	Analog GND 1	2	Analog GND 5	2	Input 8
3	TC1 Shield	3	Analog Input 1	3	Analog Input 5	3	Analog GND 8
4	TC IN2+	4	+5Vref. 2	4	+5Vref. 6	4	Input 9
5	TC IN2-	5	Analog GND 2	5	Analog GND 6	5	Analog GND 9
6	TC2 Shield	6	Analog Input 2	6	Analog Input 6	6	Input 10
7	TC IN3+	7	+5Vref. 3	7	+5Vref. 7	7	Analog GND 10
8	TC IN3-	8	Analog GND 3	8	Analog GND 7	8	CAN1 L
9	TC3 Shield	9	Analog Input 3	9	Analog Input 7	9	CAN1 H
10	TC IN4+	10	+5Vref. 4	10	CAN2 L	10	CAN1 Shield
11	TC IN4-	11	Analog GND 4	11	CAN2 H	11	Frame GND
12	TC4 Shield	12	Analog Input 4	12	CAN2 Shield	12	Batt-

Dimensional Drawing



Note:
CANopen® is a registered community trademark of CAN in Automation e.V.

Form: TDAX181001-06/19/23