

20 TC, 2 RTD, 4 Signal Inputs, 6 Relay Outputs Controller

2 CAN, SAE J1939

Modbus TCP/IP

with the Axiomatic Electronic Assistant

P/N: AX180800

Description:

The Temperature Scanner monitors up to 20 thermocouples and 2 RTD's to provide the temperature information to the engine control system over SAE J1939 CAN bus. The channels are independently configurable as Type J, K, B, E, N, R, S or T thermocouples. Temperature information can include exhaust temperature, winding temperature, and fluid temperature monitoring. All 20 channels of temperature data are automatically sent over the CAN bus when power is applied with no additional programming or configuration required. There are 4 universal signal command inputs. The control sets 6 Form C relay outputs. Integral diagnostics determine thermocouple integrity. All inputs are fully isolated from the CAN lines, and from the power supply. The two CAN channels are fully isolated from one another in the hardware which allows for different CAN networks to be connected. In the software, each will also act independently where incoming or outgoing messages can be configured to receive or send on a specific CAN channel. Modbus TCP/IP communications are also available. The scanner is enclosed in a rugged IP67 rated enclosure with an 86-pin connector. The connector is a TE Deutsch part equivalent.



Applications:

Control systems for industrial and marine power generator sets (stationary or portable)

Ordering Part Numbers:

20 TC, 2 RTD, 4 Signal Inputs, 6 Relay Outputs Controller, 2 SAE J1939, Ethernet P/N: AX180800
Axiomatic Electronic Assistant Configuration KIT, P/Ns: AX070502 , or AX070506K
Mating Plug Kit P/N: AX070164 (comprised of equivalents to TE Deutsch P/Ns: DRCP28-86SA, 80 0462-203-12141 solid sockets, and 6 0462-005-20141 solid sockets)

Block Diagram

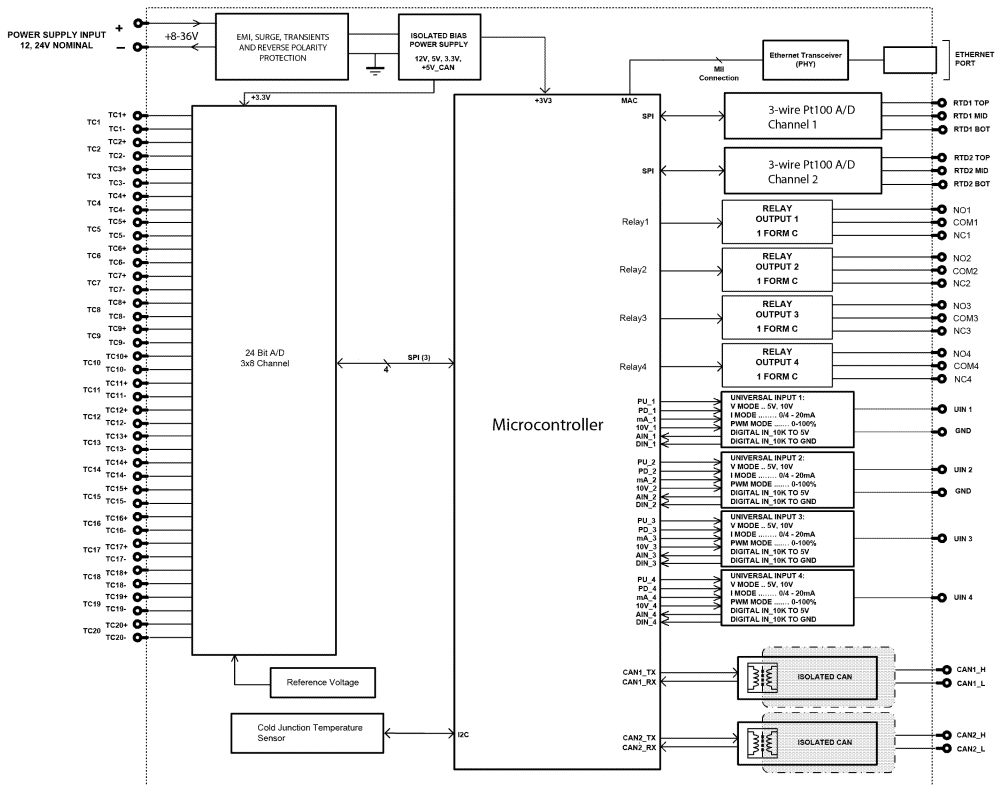

Technical Specifications

Specifications are indicative and subject to change. Actual performance will vary depending on the application and operating conditions. Users should satisfy themselves that the product is suitable for use in the intended application. All our products carry a limited warranty against defects in material and workmanship. Please refer to our Warranty, Application Approvals/Limitations and Return Materials Process as described on <https://www.axiomatic.com/service/>.

Inputs

Power Supply Input	12V or 24VDC nominal (9...60 VDC power supply range)
Supply Current	158 mA at 12 V Typical 88 mA at 24 V Typical
Protection	Reverse polarity protection is provided. Power supply input section protects against transient surges and short circuits.
Isolation	Digital isolation is 400VDC from input to ground. Three-way isolation is provided for the CAN line, inputs and power supply.
Protection	Open circuit detection Over or under temperature detection High temperature shutdown detection

Thermocouple Types	Up to 20 channels, independently configurable for B, E, J, K, N, R, S or T
Thermocouple Inputs (20)	<p>The device reads mV signals from the supported Thermocouples.</p> <p>B = 0 to 13.82 mV E = -9.835 to 76.373 mV J = -8.095 to 69.553 mV K = -6.458 to 54.886 mV N = -4.345 to 47.513 mV R = -0.226 to 21.101 mV S = -0.236 to 18.693 mV T = -6.258 to 20.872 mV</p> <p>Temperatures are configured to indicate the SAE J1939 SPN to be transmitted by that temperature input.</p> <p>Accuracy: +/- 1°C typical with cold junction compensation at ambient temperature Resolution: 0.001°C</p>
TC Scan Rate	100ms per channel, total sweep time maximum 2.2 seconds
Common Mode Readings	Input range +/- 2.5V maximum Rejection is 120db (maximum) at 2.5Vp-p (50-60Hz)
Thermal Drift	4 ppm/°C of span (maximum)
RTD Types	Up to 2 channels for Rt100 sensor type inputs with 2 or 3-wire connection. Each channel operates independently.
RTD Inputs (2)	<p>The device accepts inputs within the following range of 20 - 400 Ohms. RTD lead resistance range is 0 – 10 Ohms.</p> <p>Accuracy: +/- 0.4°C with offset calibration performed at R_{RTD} = 100R (typical at ambient temperature) Resolution: 0.001°C</p>
RTD Scan Rate	20 samples per second for all 2 channels
Signal Inputs (4)	<p>4 Universal Signal Inputs configurable as: Voltage, Current, Frequency, PWM or Digital</p> <p>12-bit Analog to Digital resolution (Voltage and Current) Protected against shorts to GND or +Vps</p> <p>Voltage Types: 0-5Vdc (Input impedance 204 kΩ) or 0-10Vdc (Input impedance 134 kΩ) 1mV resolution, accuracy +/- 0.2% error</p> <p>Current Types: 0-20 mA (Input impedance 249 kΩ) or 4-20 mA (Input impedance 249 kΩ) 1uA resolution, accuracy +/- 0.2% error</p> <p>Frequency Type: Range: 0.5 Hz to 10 kHz 0.01% resolution, accuracy +/- 0.1% error</p> <p>PWM Type: PWM Signal Frequency: 1 Hz to 10 kHz PWM Duty Cycle: 0 to 100% 0.01% resolution, accuracy +/- 1% error</p> <p>Digital Type: Active High with 10K Pullup or Active Low with 10K Pulldown resistor to GND Amplitude: up to +Vsupply</p>

Outputs

Relay Outputs (6)	<p>6 Form C relay outputs 5 A at 30 VDC NO, COM and NC pins are available.</p>
-------------------	--

Communication

CAN	2 CAN 2.0B port, protocol SAE J1939 Auto-Baud-Rate-Detection 400VDC isolation The two CAN channels are fully isolated from one another in the hardware which allows for different CAN networks to be connected. In the software, each will also act independently where incoming or outgoing messages can be configured to receive or send on a specific CAN channel.
Network Termination	According to the CAN standard, it is necessary to terminate the network with external termination resistors. The resistors are 120 Ohm, 0.25W minimum, metal film or similar type. They should be placed between CAN_H and CAN_L terminals at both ends of the network.
Ethernet	1 port 10/100 Mbit Ethernet compliant 10BASE-T. 100BASE-Tx (Auto-configuration and full-duplex is supported.) Auto-MDIX Modbus TCP/IP

General Specifications

Microprocessor	STM32F407ZGT6, 1 Mbyte Flash Memory, 192+4 Kbyte SRAM
Control Logic	User programmable functionality with the Axiomatic Electronic Assistant Refer to the User Manual.
User Interface	The Axiomatic Electronic Assistant KIT, P/Ns: AX070502, or AX070506K. Updates for Electronic Assistant are found on www.axiomatic.com under the log-in tab.
Vibration	Pending
Shock	Pending
Operating Temperature Range	-40 to 85 °C (-40 to 185 °F)
Storage Temperature Range	-50 to 120 °C (-58 to 248 °F)
Humidity	Protected against 95% humidity non-condensing, 30 °C to 60 °C
Protection	IP67
Weight	3.1 lb. (0.141 kg)
Enclosure	Rugged aluminum housing, anodized, gasket Connector: 86-pin (equivalent TE Deutsch P/N: DRCP25-86PAA-G005s) Notes: SECURE HARNESS WITH TIE WRAPS FOR HIGH VIBRATION APPLICATIONS. REQUIRES COVER TE DEUTSCH PN 4828-008-8605 (NOT INCLUDED) FOR HIGH PRESSURE SPRAY APPLICATIONS.
Mating Plug Kit	Mating Plug Kit P/N: AX070164 (equivalent to TE Deutsch DRCP28-86SA, 80 0462-203-12141 solid sockets, and 6 0462-005-20141 solid sockets) Please note that there are no wires in this plug kit. The 0462-005-20141 sockets accept 16-18 AWG wires. The 0462-203-12141 sockets accept 12-14 AWG wires.

Dimensional Drawing

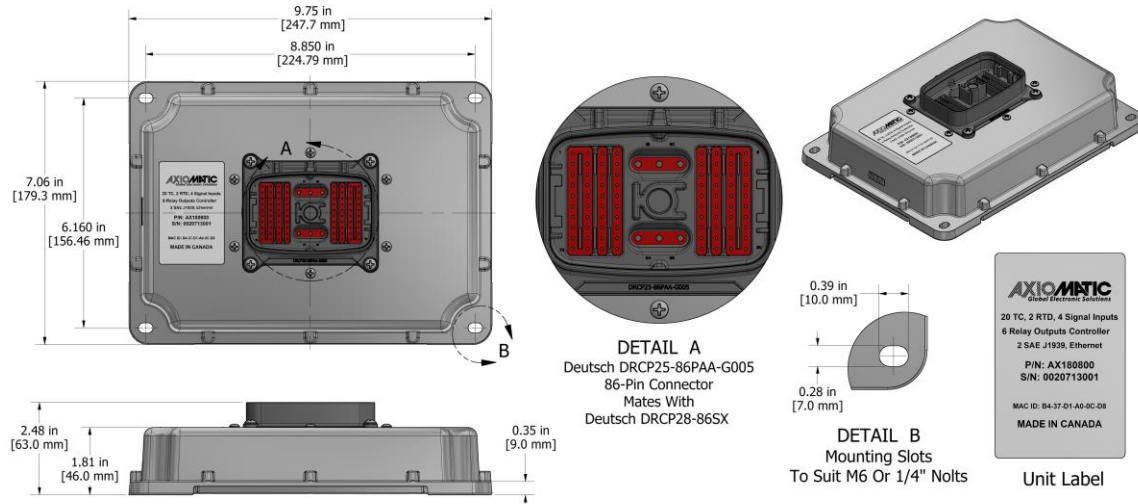

CONNECTOR PINOUT TABLE				
Pin1: TC2_IN-	Pin19: TC5_IN-	Pin37: COM_6	Pin55: RTD_B_2	Pin73: TC20_IN-
Pin2: TC2_IN+	Pin20: TC5_IN+	Pin38: NO_6	Pin56: RTD_T_1	Pin74: TC20_IN+
Pin3: TC1_IN-	Pin21: NO_3	Pin39: Spare	Pin57: TC16_IN-	Pin75: TC19_IN-
Pin4: TC1_IN+	Pin22: NC_4	Pin40: Spare	Pin58: TC16_IN+	Pin76: TC19_IN+
Pin5: NC_1	Pin23: COM_4	Pin41: TC12_IN-	Pin59: TC15_IN-	Pin77: ETH_RX_X
Pin6: COM_1	Pin24: NO_4	Pin42: TC12_IN+	Pin60: TC15_IN+	Pin78: ETH_RX_P
Pin7: NO_1	Pin25: TC8_IN-	Pin43: TC11_IN-	Pin61: RTD_M_1	Pin79: ETH_TX_N
Pin8: NC_2	Pin26: TC8_IN+	Pin44: TC11_IN+	Pin62: RTD_B_1	Pin80: ETH_TX_P
Pin9: TC4_IN-	Pin27: TC7_IN-	Pin45: IN1	Pin63: GND	Pin81: BATT-
Pin10: TC4_IN+	Pin28: TC7_IN+	Pin46: IN2	Pin64: GND	Pin82: BATT+
Pin11: TC3_IN-	Pin29: NC_5	Pin47: IN3	Pin65: TC18_IN-	Pin83: Spare
Pin12: TC3_IN+	Pin30: COM_5	Pin48: IN4	Pin66: TC18_IN+	Pin84: BATT-
Pin13: COM_2	Pin31: NO_5	Pin49: TC14_IN-	Pin67: TC17_IN-	Pin85: BATT+
Pin14: NO_2	Pin32: NC_6	Pin50: TC14_IN+	Pin68: TC17_IN+	Pin86: Spare
Pin15: NC_3	Pin33: TC10_IN-	Pin51: TC13_IN-	Pin69: CAN2_P	
Pin16: COM_3	Pin34: TC10_IN+	Pin52: TC13_IN+	Pin70: CAN2_N	
Pin17: TC6_IN-	Pin35: TC9_IN-	Pin53: RTD_T_2	Pin71: CAN_P	
Pin18: TC6_IN+	Pin36: TC9_IN+	Pin54: RTD_M_2	Pin72: CAN_N	

TDAX180800-12/04/23