

8 Channel RTD Scanner

CAN, SAE J1939

with Axiomatic Electronic Assistant

P/N: AX180300

Description:

The RTD Scanner monitors 8 RTD inputs (PT100) from a diesel engine and the temperature information is provided to the engine control system over a SAE J1939 CAN bus. The controller features auto-baud-rate detection for the CAN communications. Temperature information can include exhaust temperature, winding temperature, and fluid temperature monitoring. All channels of temperature data are automatically sent over the CAN bus when power is applied with no additional programming or configuration required. Integral diagnostics determine RTD integrity. RTD inputs are isolated from the CAN communication and power supply. During set-up, using a USB-CAN converter and a PC, the operator can configure the controller via the Axiomatic Electronic Assistant to suit a wide variety of applications.

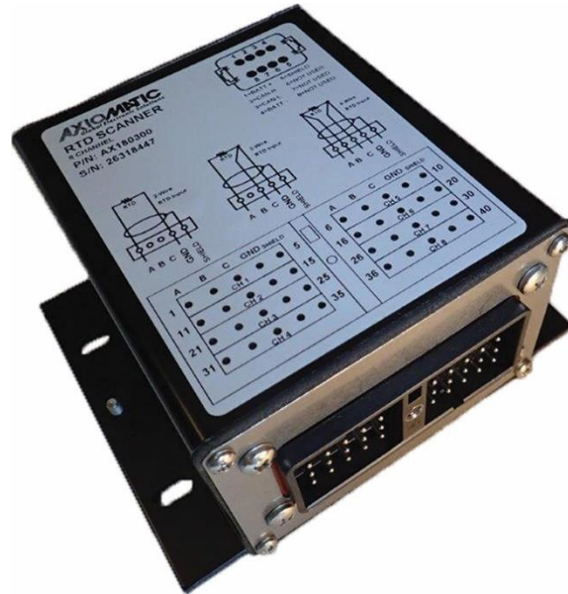

The RTD Scanner features rugged packaging and TE Deutsch connectors for an IP67 rating.

Applications:

- Stationary, portable power generator sets
- Genset control systems

Ordering Part Number:

8 Channel RTD Scanner, SAE J1939 with auto-baud-rate detection P/N: **AX180300**

Accessories:

Mating Plug KIT P/N: **AX070200**

Axiomatic Electronic Assistant Configuration KIT P/N: **AX070502** or **AX070506K**

Functional Block Diagram

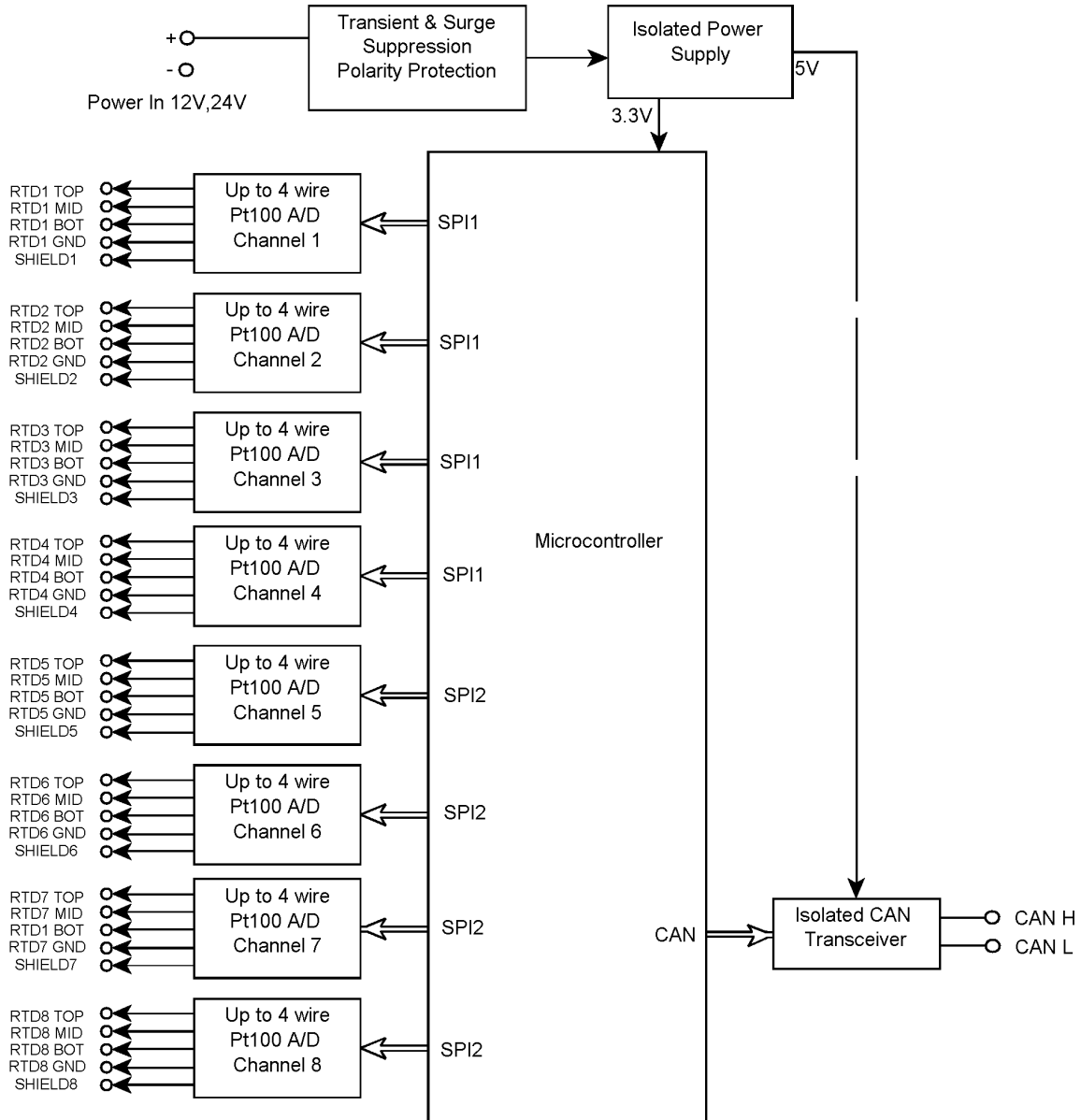

Technical Specifications

Specifications are indicative and subject to change. Actual performance will vary depending on the application and operating conditions. Users should satisfy themselves that the product is suitable for use in the intended application. All our products carry a limited warranty against defects in material and workmanship. Please refer to our Warranty, Application Approvals/Limitations and Return Materials Process as described on <https://www.axiomatic.com/service/>.

Input

Power Supply Input	12 or 24 VDC nominal (8 to 65 VDC power supply range) 50 or 60 Hz is user selectable.
Quiescent Current	45 mA @ 12 VDC; 20 mA @ 24 VDC typical
Protection	Reverse polarity protection is provided. Power supply input section protects against transient surges and short circuits and is isolated from RTD inputs.
RTD Types	Up to 8 channels, independently configurable for 2-wire, 3-wire, or 4-wire RTDs
RTD Inputs	Each channel independently supports specific sensors IEC 0.00385, JIS 0.003916, US 0.003902, Legacy 0.003920, SAMA 0.003923. A user defined coefficient would enable custom Callendar-Van Dusen constants to be set for sensors not listed above. The device accepts inputs within the following range of 20 to 400 Ω . Accuracy (typical at ambient temperature): <ul style="list-style-type: none"> • 4% (for 2-wire mode) • 2% (for 3-wire and 4-wire modes) Resolution: 0.001°C Isolation voltage is 1500 VAC (rms) or 2550 V for 1 sec.
Scan Rate	110ms
Common Mode Readings	Input range: ± 4 V maximum Rejection: 100 db at 5 Vp-p (50-60 Hz)
Thermal Drift	150 ppm/°C of span (maximum)
Isolation	Digital isolation is 400 VDC from input to ground. Three-way isolation is provided for the CAN line, inputs, and power supply.
SPNs and PGNs	The SPN drop list includes all temperature SPNs from the J1939-71 standard published up to January of 2009. If an SPN is not supported by the drop list, the user can select a zero SPN, which then allows them to define the SPN and PGN per the application requirements. One-byte parameters have a resolution of 1°C/bit and a range of -40°C to 210°C. Two-byte parameters have resolution of 0.03125°C/bit and a range of -273°C to 1735°C (per SAE J1939). The Parameter Group Number (PGN) that will be used to send a temperature to the J1939 network will be entirely dependent on the Suspect Parameter Number (SPN) that was selected for that channel. In all cases, the PGN is a PDU2 type. Each PGN has a predefined priority and repetition rate associate with it.
Averaging	The average temperature of all the active channels can be broadcasted to the network using the default "Engine Average Information" PGN, or on a Proprietary B message.
Protection	Open circuit detection Over or under temperature detection High temperature shutdown detection

Communication

CAN	1 CAN 2.0B port, Protocol SAE J1939 250 kbit/s, 500 kbit/s, 667 kbit/s, 1 Mbit/s auto-baud-rate detection Digital isolation is provided for the CAN line.
Network Termination	According to the CAN standard, it is necessary to terminate the network with external termination resistors. The resistors are 120 Ω , 0.25 W minimum, metal film or similar type. They should be placed between CAN_H and CAN_L terminals at both ends of the network.

General Specifications

Microcontroller	STM32F413CGU6, 1.5MB Flash, 320KB RAM
Control Logic	User programmable functionality with the Axiomatic Electronic Assistant: <ul style="list-style-type: none"> Node address is auto configurable as per J1939-81 and/or via customer configuration. Monitored parameters and diagnostics are user selectable from a drop-down list in the EA. Monitored parameters and diagnostics are read-only over the network. All parameter locations have default values that do not conflict. Units are pre-configured with default values at the factory. Refer to the user manual. Parameter values and diagnostic error codes are retained when the modules are de-energized. Easily selectable SPNs from a drop-down list of the temperature SPNs supported by SAE J1939. User defined SPN and PGN's configurable with Axiomatic Electronic Assistant to suit the application. Configurable ECU Instance in the NAME to allow for multiple ECUs on the same network. The bit-rate is 250 kbit/s. Other bit-rates (125 kbit/s, 500 kbit/s or 1 Mbit/s) can be factory programmed on request. Contact Axiomatic for an ordering P/N. Module is fully functional during configuration and communications.
SAE J1939 Profile	For J1939 compliance (SAE, Recommended Practice for a Serial Control and Communications Vehicle Network, October 2007), all modules comply with the applicable portions of the following. <ul style="list-style-type: none"> SAE J1939-21, Dec 2006, Data Link Layer SAE J1939-71, Sep 2013, Application Layer SAE J1939-73, Feb 2010, Application Layer – Diagnostic SAE J1939-81, March 2017, Network Management <i>Customer specific proprietary extensions can also be included in the SAE J1939 profile on request.</i>
Diagnostics	Configurable Diagnostic Messaging parameters Diagnostic Log is maintained in non-volatile memory. Each RTD channel could be configured to send diagnostic messages to the network if the temperature goes out of range. When sending an “Active Diagnostic Trouble Code” (DM1) or a “Previously Active Diagnostic Trouble Codes” (DM2) message, the controller will use the appropriate Diagnostic Trouble Code (DTC). As defined by the standard, this is a combination of the Suspect Parameter Number (SPN), the Failure Mode Indicator (FMI), Occurrence Count (OC) and the SPN Conversion Method (CM).
User Interface	Axiomatic Electronic Assistant, P/N AX070502 or AX070506K Updates for the EA are found on www.axiomatic.com
UL and cUL Compliance	Standard for Controllers for Use in Power Production, CAN/ULC 6200, 1st edition
CE/ UKCA Compliance	CE/ UKCA marking 2004/108/EC (EMC Directive) 2011/65/EU (RoHS Directive)
Marine Type Approvals	ABS, BV, CCS, DNV, LR, RINA
Vibration	7.32 Grms for a device rigidly mounted to a generator housing The marine type approval process tested to 4.0 G per IEC 60068-2-6, Test Fc.
Operating Temperature	-40°C to 85°C (-40°F to 185°F)
Storage Temperature	-50°C to 120°C (-58°F to 248°F)
Humidity	Protected against 95% humidity non-condensing, 30°C to 60°C
Weight	2.1 lbs. (0.953 kg)
Protection	IP67
Enclosure and Dimensions	Rugged aluminum housing, stainless steel end plates, neoprene gaskets 5.86 in x 5.72 in x 2.87 in (149 mm x 145.3 mm x 73 mm)

Electrical Connections

Power and CAN:

1 8-pin TE Deutsch equivalent connector, P/N: DT13-08PA

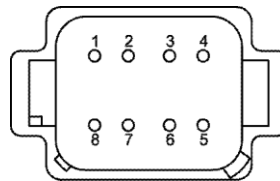

Pin #	Function
1	Power+
2	CAN_H
3	CAN_L
4	Power -
5	Shield
6	Not Used
7	Not Used
8	Not Used

RTSs:

1 40-pin TE Deutsch equivalent connector, P/N: DRC13-40PA

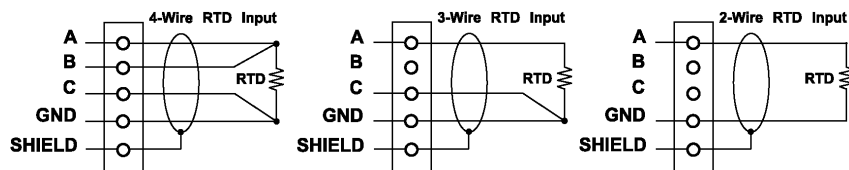

RTD MODULE - PIN OUT

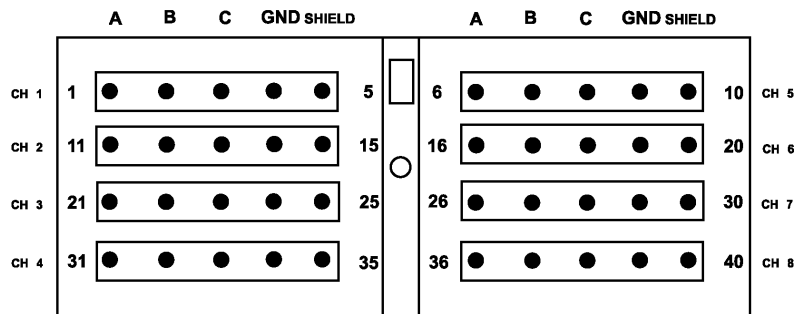

**FRONT VIEW OF
MODULE MOUNTED CONNECTOR**

Mating Connectors	<p>Power and CAN: TE Deutsch equivalent connector, P/N: DT06-08SA, wedgelock W8S and sockets 0462-201-16141</p> <p>RTDs: TE Deutsch equivalent connector, P/N: DRC16-40SE-A, or DRC18-40SA, or DRC16-40S with sockets 0462-201-16141</p> <p>Mating Plug KIT P/N: AX070200 This kit includes 1 plug DT06-08SA, 1 plug DRC16-40S, 1 wedgelock W8S, 48 contact sockets 0462-201-16141, and 24 sealing plugs 114017. These items may also be available from any local TE Deutsch distributor. Note: A crimping tool from TE Deutsch is required to connect wiring to the sockets, P/N: HDT 48-00 or equivalent (not supplied).</p>
Mounting	It can be mounted directly on the power generator set or remotely.

Dimensional Drawing

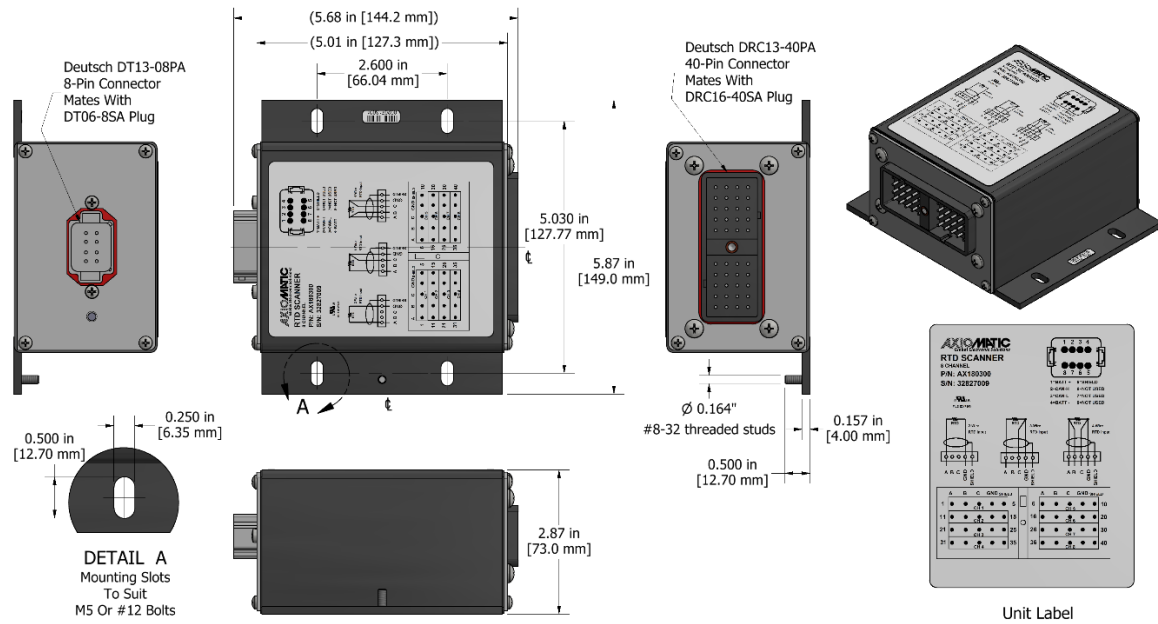

Form: TDAX180300-02/15/2024