

Automotive Ethernet to CAN Converter

CAN 2.0B

0.7A Output

P/N: AX141530

Features:

- 12V, 24Vdc input power (nominal) for connection to a battery
- 1 Automotive Ethernet port (100 Mbps)
- 1 CAN port (CAN 2.0B) with Auto-baud-rate-detection
- 0.7A Output
- Power, Link and Speed LED indicators
- Surge, reverse polarity, input overvoltage, and input undervoltage protection
- Master or Slave functionality factory set or can be configured.
- IP67
- Compact, 2 M12 connectors
- Web-based configuration
- CE marking
- Suitable for high vibration and shock environments



Applications:

- Off-highway equipment, mining equipment, industrial trucks

Ordering Part Number:

Automotive Ethernet to CAN Converter – configurable as master or slave: **AX141530**

Automotive Ethernet to CAN Converter, Master (default setting): **AX141530-M**

Automotive Ethernet to CAN Converter, Slave (default setting): **AX141530-S**

Accessories:

For web-based configuration, select the converter below to complement the M or S setting in AX141530. For example, a M setting in AX141530 means the AX141500-S should be selected. Or use a standard off the shelf Automotive Ethernet to Ethernet converter.

Automotive Ethernet to Ethernet Converter, Master: **AX141500-M**

Automotive Ethernet to Ethernet Converter, Slave: **AX141500-S**

AX070532 CAN Cable - 1.5 m (5 ft.), 5-pin M12 A-coded, Unterminated Leads

AX070534 Power and AE Cable – 2 m (6.56 ft.), 4-pin Male M12 D-coded, Unterminated Leads

Description: The Axiomatic Automotive Ethernet to CAN Converter provides a purely physical, bi-directional conversion between Automotive Ethernet (100BASE-T1) and CAN 2.0B via PHY transceivers. No packets are stored or modified in this device. The Automotive Ethernet fieldbus supports bit rates of 100 Mbps and the CAN bus supports baud rates up to 1 Mbps. Status LEDs provide information on connection link, and communication. The converter is designed for the harsh environments of off-highway or industrial equipment. Automotive Ethernet networks use a 2 wire, unshielded, twisted pair UTP cable and save cabling costs for the machine builder. A 0.7A output is available to power another device downstream on the system.

The unit may be configured via the web server as Master or Slave functionality. Its default setting is in the slave mode. The Master mode works if the connected device has a transceiver set to slave mode. The Slave mode works when the connected device has a transceiver set to master mode. Hard setting the master/slave relationship saves on setup-time costs and ensures that the Automotive Ethernet link is established quickly. As a comparison, regular Ethernet converters rely on auto-negotiation to determine master and slave. The converter is configured via a web server interface using the AE to Ethernet Converter or a similar device to access Ethernet which links to the web server as shown below.

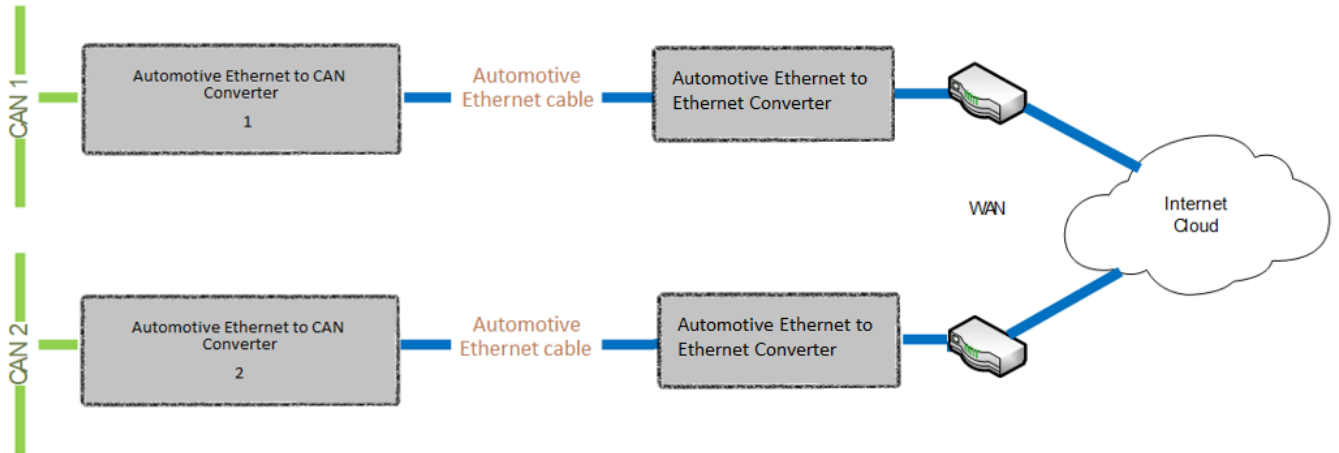

Functional Block Diagram

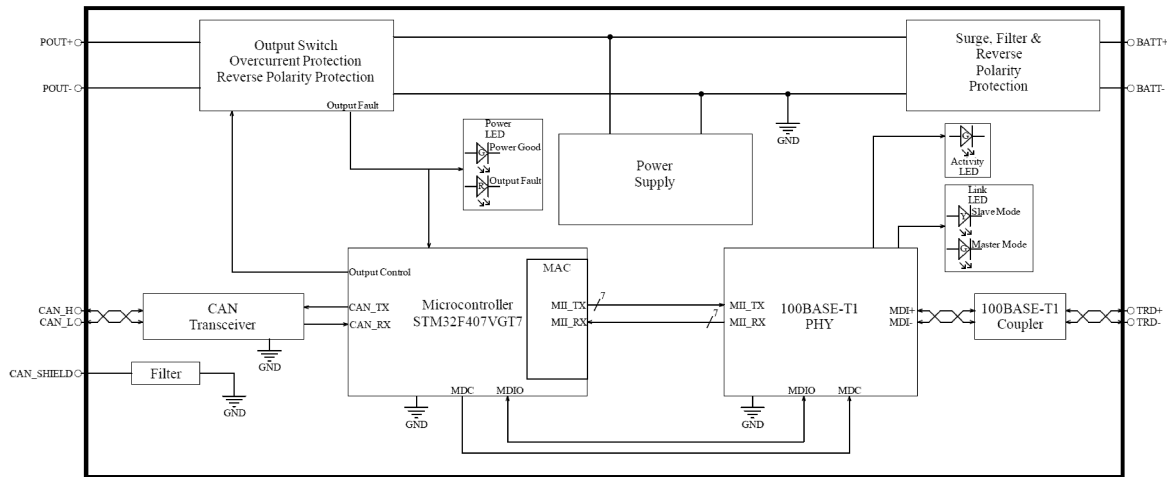

Technical Specifications:

Specifications are indicative and subject to change. Actual performance will vary depending on the application and operating conditions. Users should satisfy themselves that the product is suitable for use in the intended application. All our products carry a limited warranty against defects in material and workmanship. Please refer to our Warranty, Application Approvals/Limitations and Return Materials Process as described on <https://www.axiomatic.com/service/>.

Input

Power Supply Input - Nominal	12V, 24Vdc nominal (9...36VDC power supply range)
Protections	Surge protection is provided. Reverse polarity protection up to -50V is provided. Input overvoltage (45V) and input undervoltage (6V) protection are provided. Input circuitry protects against load dumps.
Power Consumption	45 mA @ 12 V; 26 mA @ 24V typical
Power LED	GREEN= Power ON

Output

Current Output	0.7A
Voltage Drop	1 V Maximum
Protection	Overcurrent >1A; Short to Battery

Automotive Ethernet

Port Type	1 port 100BASE-T1 (Automotive Ethernet) compliant Automatic Polarity Correction Default configuration: Slave (configurable via CAN or RS-232)																											
PHY	Texas Instruments DP83TC811S-Q1 Transceiver																											
LED's	<p><i>Table 1. Converter LED Indicators</i></p> <table border="1"> <thead> <tr> <th>Name</th> <th>Color</th> <th>Description</th> </tr> </thead> <tbody> <tr> <td rowspan="2">Power</td> <td rowspan="2">Green/Red</td> <td>Off</td> <td>The converter is not powered.</td> </tr> <tr> <td>Green</td> <td>The converter is powered. CAN Power Output is in normal condition.</td> </tr> <tr> <td rowspan="3">Ethernet Link</td> <td rowspan="3">Green</td> <td>Red</td> <td>CAN Power Output is in a fault condition.</td> </tr> <tr> <td>On</td> <td>Automotive Ethernet is in Master Mode.</td> </tr> <tr> <td>Yellow</td> <td>Automotive Ethernet is in Slave Mode.</td> </tr> <tr> <td rowspan="4">Ethernet Activity</td> <td rowspan="4">Green</td> <td>None</td> <td>Connection is down</td> </tr> <tr> <td>On</td> <td>Automotive Ethernet link is established.</td> </tr> <tr> <td>Off</td> <td>Automotive Ethernet link is down.</td> </tr> <tr> <td>Blinking</td> <td>Automotive Ethernet link is up and active.</td> </tr> </tbody> </table>	Name	Color	Description	Power	Green/Red	Off	The converter is not powered.	Green	The converter is powered. CAN Power Output is in normal condition.	Ethernet Link	Green	Red	CAN Power Output is in a fault condition.	On	Automotive Ethernet is in Master Mode.	Yellow	Automotive Ethernet is in Slave Mode.	Ethernet Activity	Green	None	Connection is down	On	Automotive Ethernet link is established.	Off	Automotive Ethernet link is down.	Blinking	Automotive Ethernet link is up and active.
Name	Color	Description																										
Power	Green/Red	Off	The converter is not powered.																									
		Green	The converter is powered. CAN Power Output is in normal condition.																									
Ethernet Link	Green	Red	CAN Power Output is in a fault condition.																									
		On	Automotive Ethernet is in Master Mode.																									
		Yellow	Automotive Ethernet is in Slave Mode.																									
Ethernet Activity	Green	None	Connection is down																									
		On	Automotive Ethernet link is established.																									
		Off	Automotive Ethernet link is down.																									
		Blinking	Automotive Ethernet link is up and active.																									
Protection	ESD protection up to 30 kV per IEC 61000-4-2 (ESD) on both auto-ethernet and CAN lines																											
Protocol	Automotive Ethernet IEEE 802.3bw																											

Configuration Ports

CAN	1 CAN (SAE J1939) port
Auto-baud-rate-detection	1000, 666.6, 500, 250, 125, 100, 83.3(3), 50, 20, 10 baud rates Auto-baud-rate detection
User Interface	Via the Axiomatic Electronic Assistant KIT, P/Ns: AX070502 or AX070506K

General Specifications

Functionality	Model AX141530 can be configured to acts as a master or a slave. Refer to the User Manual.
Microprocessor	STM32F407VGT7
Compliance	CE marking
Vibration	Random Vibration: Z-axis tracked vehicle profile (5 hr/axis in all 3 axes) Sinusoidal Component: 8.9 G Sine sweep, 2.5 hr/axis in all 3 axes
Shock	50 g, 5 impacts per test, 6-20 ms impact duration
Operating Conditions	-40 to 80°C (-40 to 176°F)
Storage Temperature	-40 to 85°C (-40 to 185°F)
Protection	IP67
Weight	0.15 lb. (0.068 kg) preliminary
Installation	The typical maximum wire harness length for Automotive Ethernet cabling is 15 m.
Enclosure and Dimensions	See dimensional drawing, Figure 2.0. Nylon 6/6, 30% glass fill UL 94V-0 Ultrasonically welded

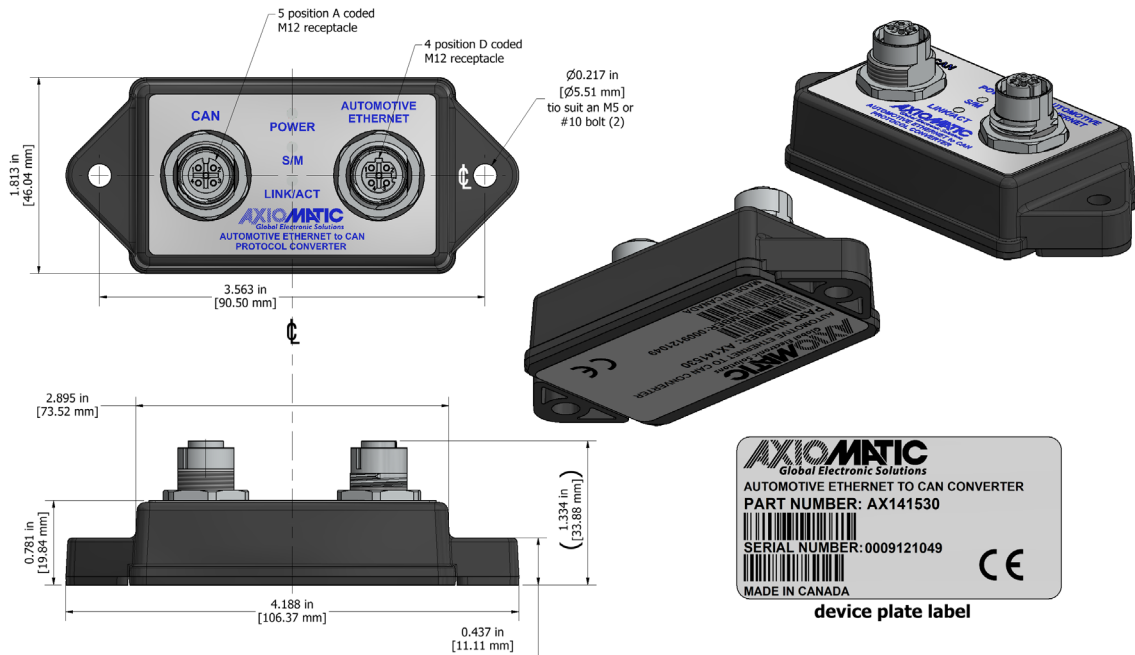
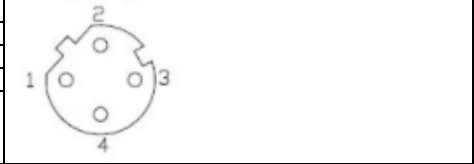
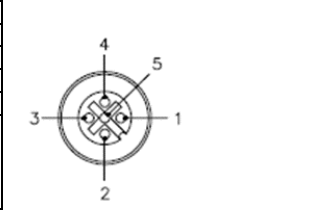

Figure 2.0. Dimensional Drawing

<p>Electrical Connections</p>	<p>1 Phoenix Contact M12 4-pin connector (D-coded), P/N: 1441752 (Connector 1) Automotive Ethernet Port: Power In, Ethernet</p> <table border="1" data-bbox="589 1024 862 1186"> <thead> <tr> <th>PIN#</th> <th>Description</th> </tr> </thead> <tbody> <tr> <td>1</td> <td>TRD N</td> </tr> <tr> <td>2</td> <td>BATT-</td> </tr> <tr> <td>3</td> <td>TRD P</td> </tr> <tr> <td>4</td> <td>BATT+</td> </tr> </tbody> </table>  <p>1 Phoenix Contact M12 5-pin connector (A-coded), P/N: 1441778 (shown) (Connector 2) CAN / Power Output Port:</p> <table border="1" data-bbox="589 1276 1003 1486"> <thead> <tr> <th>PIN#</th> <th>Description</th> </tr> </thead> <tbody> <tr> <td>1</td> <td>CAN Shield (NOT USED)</td> </tr> <tr> <td>2</td> <td>P OUT +</td> </tr> <tr> <td>3</td> <td>P OUT -</td> </tr> <tr> <td>4</td> <td>CAN H</td> </tr> <tr> <td>5</td> <td>CAN L</td> </tr> </tbody> </table> 	PIN#	Description	1	TRD N	2	BATT-	3	TRD P	4	BATT+	PIN#	Description	1	CAN Shield (NOT USED)	2	P OUT +	3	P OUT -	4	CAN H	5	CAN L
PIN#	Description																						
1	TRD N																						
2	BATT-																						
3	TRD P																						
4	BATT+																						
PIN#	Description																						
1	CAN Shield (NOT USED)																						
2	P OUT +																						
3	P OUT -																						
4	CAN H																						
5	CAN L																						
<p>Mating Connectors</p>	<p>Mating connectors should meet the following standard for M12 Connectors, IEC 61076-2-101:2012.</p>																						
<p>Mating Wire Harnesses</p>	<p>The following part numbers are available from Axiomatic. AX070532 CAN Cable - 1.5 m (5 ft.), 5-pin M12 A-coded, <i>Unterminated Leads</i> AX070534 Power and AE Cable – 2 m (6.56 ft.), 4-pin Male M12 D-coded, <i>Unterminated Leads</i></p>																						

Form: TDAX141530-06/29/23