

Modbus TCP/IP to CAN Converter

P/N: AX140940

Features:

- 12V, 24Vdc input power (nominal) for connection to a battery
- 1 CAN port (2.0A and B protocol) and SAE J1939
- 1 Ethernet port to communicate with Modbus master or multiple slave devices on a machine (10/100 Mbps, auto-negotiation and full-duplex supported))
- Supports CAN and Modbus message filtering
- Power, Link and Speed LED indicators
- 1 power output (Vps) to power an external device over the Ethernet cable
- Surge, Reverse polarity, input overvoltage, input undervoltage, and output overcurrent protection
- IP66
- Compact, 2 M12 connectors
- Suitable for high vibration and shock environments
- CE marking
- Available as a kit with cables, p/n: AX140940K



Applications:

- Off-highway equipment, mining equipment
- Industrial control panels

Ordering Part Numbers:

Modbus TCP/IP to CAN Converter: **AX140940**

Accessories:

AX070531 Ethernet and Power Cable - 1.7m (5.5 ft.), 8-pin M12 A-coded, Unterminated Leads, Ethernet Jack

AX070532 CAN Cable - 1.5 m (5 ft.), 5-pin M12 A-coded, Unterminated Leads

Or you can order the items as a service tool KIT.

The **AX140940K**, is comprised of the following items:

- AX140940 *Ethernet-CAN Converter*;
- AX070531 *Ethernet and Power Cable - 1.7m (5.5 ft.), 8-pin M12 A-coded, Unterminated Leads, Ethernet Jack*;
- and AX070532 *CAN Cable - 1.5 m (5 ft.), 5-pin M12 A-coded, Unterminated Leads*.

Description: The Modbus TCP/IP to CAN Converter operates as a simple data converter capable of handling communication between Modbus TCP/IP master or slave devices and a machine's CAN bus. Communication can occur in either direction, Modbus to CAN or CAN to Modbus. CAN frames are converted into a simple data encoding and sent over Ethernet to the Modbus device. Likewise, data received from the Modbus device is decoded into CAN frames and sent via CAN bus to the connected CAN device. CAN and Modbus message filtering is supported. The converter can be utilized to optimize space and eliminate the need for more complex devices. The Ethernet port can communicate up to 100 Mbps and has LED indicators showing the status and speed. The CAN port has overcurrent protection that triggers at 1A. It supports high speed CAN with a baud rate of up to 1 Mbps. All standard and extended CAN frames are supported. It can interface with SAE J1939. The power can be delivered to the CAN port over the Ethernet connection. Protection is provided. The converter is designed for the harsh environments of off-highway equipment or industrial equipment.

The Modbus to CAN Converter firmware contains two independent parts: the *Communication Device* and the *Web Server*, see Figure 1:

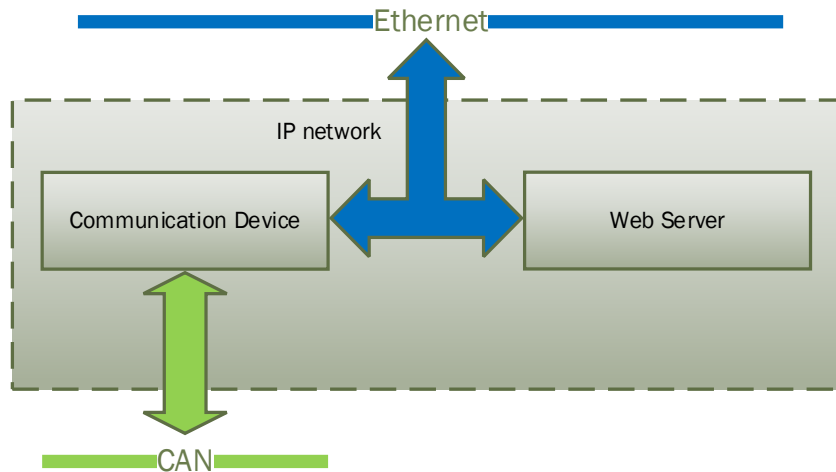

Figure 1. Converter Firmware Architecture

The *Communication Device* is responsible for the protocol conversion between CAN and Modbus TCP/IP networks and the *Web Server* provides the converter user interface.

There are two major approaches in using the converter. One is to use the converter on its own as a CAN extender or a baud rate converter.

For example, a pair of coupled converters can synchronize two CAN networks. This example can be extended to several CAN networks running at different baud rates, connected by using a pair of coupled Modbus to CAN Converters.

The second approach is to use the converter as a CAN gateway or Modbus gateway. The device's Modbus gateway can transfer Modbus data between different devices connected over the IP network. The device can also work as CAN gateway to receive and transmit CAN messages. For example, if the device is configured to work as a CAN to Modbus converter, at the same time it can also be configured to receive CAN messages from a particular CAN ECU source address and forward it to any other configured CAN destination address. So, it works as a CAN gateway to forward CAN data from a source address to a different destination address.

Technical Specifications:

Specifications are indicative and subject to change. Actual performance will vary depending on the application and operating conditions. Users should satisfy themselves that the product is suitable for use in the intended application. All our products carry a limited warranty against defects in material and workmanship. Please refer to our Warranty, Application Approvals/Limitations and Return Materials Process as described on <https://www.axiomatic.com/service/>.

Functional Block Diagram

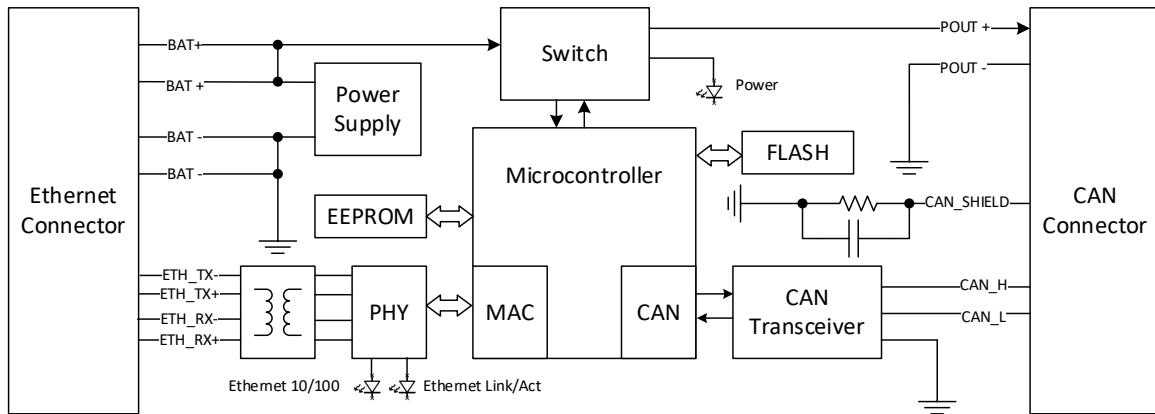

Input Specifications

Power Supply Input - Nominal	12V, 24Vdc nominal (9...36VDC power supply range)
Protections	Surge and reverse polarity protection are provided. Input overvoltage (37V), input undervoltage (6V) and output overcurrent protection are provided.
Power Consumption	2 Watts @ 12Vdc maximum
Power LED	GREEN= Power ON RED = Fault condition GREEN/RED = Power OFF

Output Specifications

Power	Pass-through power from the power supply input Power output is available from Port 2. 9...36Vdc (Vps) 0.7A maximum pass-through current Voltage Drop 1V maximum Overcurrent protection Short to Battery and Short to Ground protection
-------	--------------------------------------------------------------------------------------------------------------------------------------------------------------------------------------------------------------------------------------------------------------

Ethernet Port

Port Type	1 port 10/100 Mbit Ethernet compliant 10BASE-T, 100BASE-Tx (auto-configuration and full-duplex supported)
MDIX	Auto-MDIX
LEDs	2 GREEN for Ethernet LINK/ACT: ON means connection (LINK) Flashing means activity (ACT) OFF means Ethernet connection is down Transmission Speed: 100 Mbit/s = ON 10 Mbit/s = OFF
Protocols	Ethernet IEEE 802.3, IP, ICMP, ARP, TCP, HTTP, Proprietary Protocols
Modbus Slave Mode	Up to 32 bi-directional simultaneous connections
Modbus Master Mode	1 remote bi-directional connection
Web Server	Provided
Internal Diagnostics	Health status is transmitted in heartbeat messages. It is also available from the web server.

CAN Port

Port Type	1 port High speed, ISO 11898-2 compatible, 1 Mbit/s Shield is provided.
Protocol	CAN 2.0A and B protocol Supports SAE J1939 (Data frames and remote frames with standard and extended ID's are supported.)

Baud rate (kBit/s)	1000, 666.6, 500, 250, 125, 100, 83.3(3), 50, 20, 10 baud rates (user programmable)
--------------------	-------------------------------------------------------------------------------------

General Specifications

Documentation	User Manual, UMAX140940
Compliance	CE, RCM and UKCA marking (pending)
EMC Compliance	DIN EN 13309:2010 as well as ISO13766-1:2018 (pending) EN61000-6-4; 2005 Emission Standard for Industrial Environments EN61000-6-2: 2007 Generic Standards – Immunity for Industrial Environments EN61000-4-2: ESD, Level 4 (15 kV air/8 kV contact) at Criteria B EN61000-4-4: EFT/burst Immunity, Test Level 1 (500V power/250V signal lines) at Performance Criteria B EN61000-4-5: Surge Immunity, Test Level 1 (500V) at Performance Criteria B.
Vibration	Random Vibration: 6.86 Grms peak, Z-axis tracked vehicle profile (5 hr/axis in all 3 axes) Sinusoidal Component: 8.9 G Sine sweep, 2.5 hr/axis in all 3 axes
Shock	50 g, 5 impacts per test, 6-20 ms impact duration
Operating Conditions	-40 to 70°C (-40 to 158°F)
Storage Temperature	-40 to 85°C (-40 to 185°F)
Protection	IP66 (IEC 60529)
Weight	0.183 lb. (0.083 kg)
User Interface	Web server based interface (custom) Refer to Figure 2.0. Configurable parameters include: of IP address, baud rate, server port, Remote IP address, Remote Port, and Power output to CAN port ON/OFF. Diagnostic information includes: CAN Frames Received, CAN Frames sent, Ethernet Messages received, Ethernet Messages sent, and Device Health status (heartbeat).

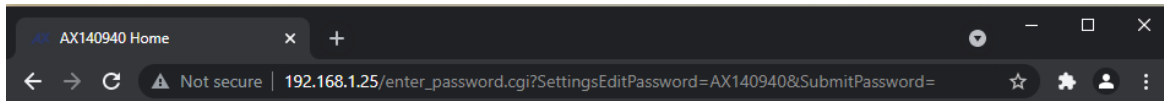

AXIOMATIC Global Electronic Solutions CAN - ModbusTCP/IP Converter

- [Home](#)
- [Main Settings](#)
- [CAN RX Settings](#)
- [CAN TX Settings](#)
- [Modbus Slave Settings](#)
- [Modbus Master Settings](#)
- [Diagnostics Routing Settings](#)
- [Upload/Download Settings](#)
- [Firmware](#)

DEVICE INFORMATION	
Part Number: AX140940 Serial Number: 0032820186 Firmware Version: V1.00	
ETHERNET	
MAC Address: B4:37:D1:A0:0F:7F	
Server	Device IP Address: 192.168.1.25 Web Server Port: 80 Device Subnet Mask: 255.255.255.0
Client	Remote IP Address: 192.168.1.1 Remote Port: 502
CAN	
Baud Rate: 500 kbit/s Auto Baud Rate Enabled: Yes Switched Power Out: No	
DIAGNOSTICS	
CAN Frames Received: 0 CAN Frames Sent: 2 Ethernet Messages Received: 215 Ethernet Messages Sent: 100	

Figure 2.0 – Web-based User Interface – Converter Homepage

Enclosure and Dimensions	See dimensional drawing, Figure 3.0. Nylon 6/6, 30% glass fill UL 94V-0 Ultrasonically welded
--------------------------	--------------------------------------------------------------------------------------------------------

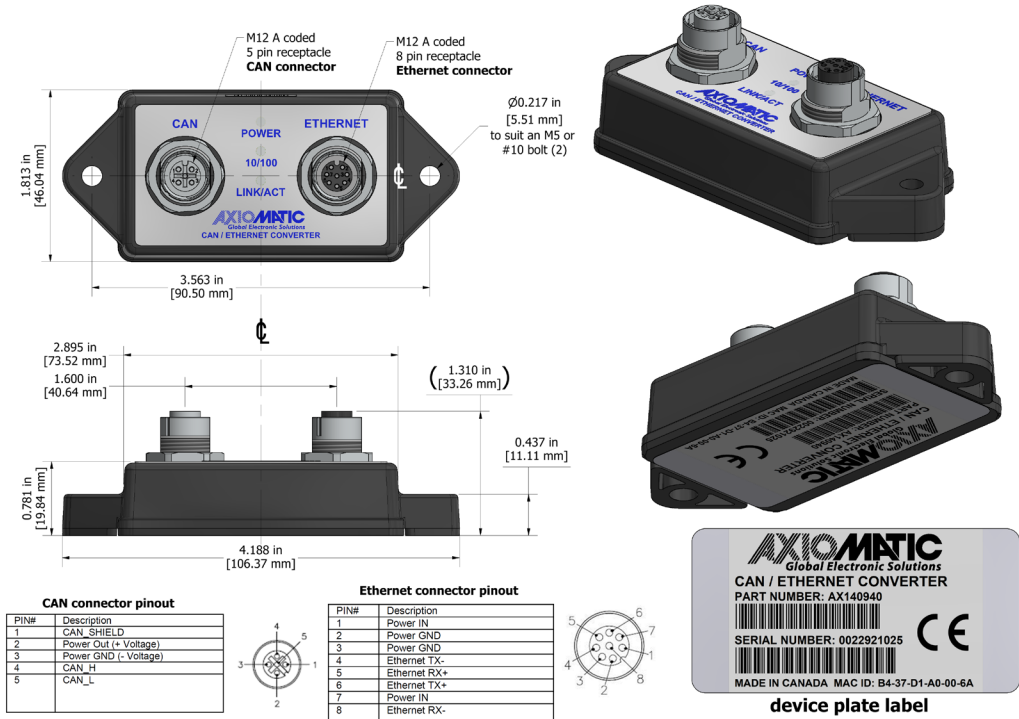

Figure 2.0. Dimensional Drawing

Electrical Connections	<p>1 Phoenix Contact M12 8-pin connector (A-coded), P/N: 1441817 (Connector 1) Ethernet Port: Power In, Ethernet</p> <table border="1"> <thead> <tr> <th>PIN#</th> <th>Description</th> </tr> </thead> <tbody> <tr> <td>1</td> <td>Power IN</td> </tr> <tr> <td>2</td> <td>Power GND</td> </tr> <tr> <td>3</td> <td>Power GND</td> </tr> <tr> <td>4</td> <td>Ethernet TX-</td> </tr> <tr> <td>5</td> <td>Ethernet RX+</td> </tr> <tr> <td>6</td> <td>Ethernet TX+</td> </tr> <tr> <td>7</td> <td>Power IN</td> </tr> <tr> <td>8</td> <td>Ethernet RX-</td> </tr> </tbody> </table> <p>1 Phoenix Contact M12 5-pin connector (A-coded), P/N: 1441778 (Connector 2) CAN Port: Power Out, CAN</p> <table border="1"> <thead> <tr> <th>PIN#</th> <th>Description</th> </tr> </thead> <tbody> <tr> <td>1</td> <td>CAN_SHIELD</td> </tr> <tr> <td>2</td> <td>Power Out (+ Voltage)</td> </tr> <tr> <td>3</td> <td>Power GND (- Voltage)</td> </tr> <tr> <td>4</td> <td>CAN_H</td> </tr> <tr> <td>5</td> <td>CAN_L</td> </tr> </tbody> </table>	PIN#	Description	1	Power IN	2	Power GND	3	Power GND	4	Ethernet TX-	5	Ethernet RX+	6	Ethernet TX+	7	Power IN	8	Ethernet RX-	PIN#	Description	1	CAN_SHIELD	2	Power Out (+ Voltage)	3	Power GND (- Voltage)	4	CAN_H	5	CAN_L
PIN#	Description																														
1	Power IN																														
2	Power GND																														
3	Power GND																														
4	Ethernet TX-																														
5	Ethernet RX+																														
6	Ethernet TX+																														
7	Power IN																														
8	Ethernet RX-																														
PIN#	Description																														
1	CAN_SHIELD																														
2	Power Out (+ Voltage)																														
3	Power GND (- Voltage)																														
4	CAN_H																														
5	CAN_L																														
Mating Connectors	Mating connectors should meet the following standard for M12 Connectors, IEC 61076-2-101:2012. They should be A-coded.																														