

Features

- Operational 9 to 36 VDC (12 or 24 VDC)
- Integrated TE Deutsch equivalent 6-pin connector
- Compact, fully sealed enclosure, IP67
- Designed for EMC compliance
- Configure with Axiomatic Electronic Assistant



Applications

Distributed controls in

- Commercial vehicles
- Off-highway equipment
- Oil and gas equipment
- Industrial equipment
- Agricultural equipment

Ordering Part Number

CAN to 1 Signal Output Controller - P/N: **AX130760**

Accessories:

Mating Plug KIT - P/N: **AX070119**

Axiomatic Electronic Assistant KIT - P/N: **AX070502**, or **AX070506K**

Description

CAN to 1 Signal Output Controller accepts power supply voltages from 9 to 36 VDC.

Versatile control algorithms/ function blocks allow the user to configure the controller for a wide range of applications without the need for custom firmware. All logical function blocks on the unit are inherently independent from one another but can be configured to interact with each other. All parameters are configurable using Axiomatic Electronic Assistant.

The hardware design allows for the controller to have a wide range of output types: Current, Voltage, and PWM.

It can operate at standard 250 kbit/s and 500 kbit/s and non-standard 667 kbit/s and 1 Mbit/s baud rates. The required baud rate is detected automatically upon connection to J1939 CAN network.

Block Diagram

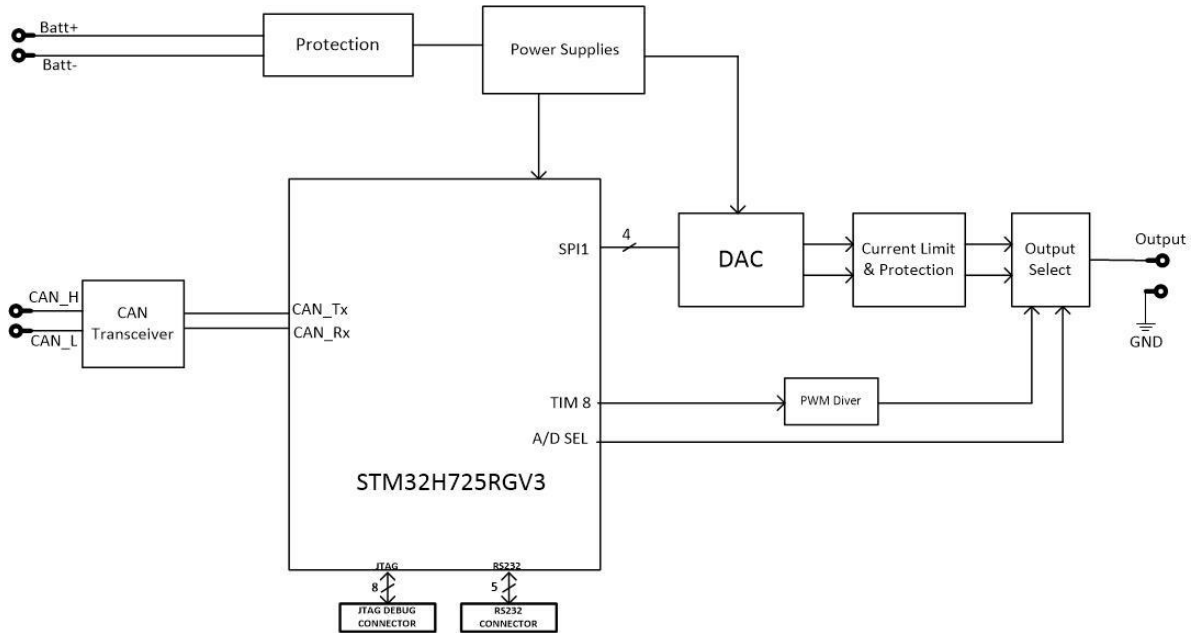

Technical Specifications

Specifications are indicative and subject to change. Actual performance will vary depending on the application and operating conditions. Users should satisfy themselves that the product is suitable for use in the intended application. All our products carry a limited warranty against defects in material and workmanship. Please refer to our Warranty, Application Approvals/Limitations and Return Materials Process as described on <https://www.axiomatic.com/service/>.

Power

Power Supply Input	12 or 24 VDC nominal (9 to 36 VDC)
Quiescent Current	52.6 mA @ 12 V and 28.4 mA @ 24 V
Surge and Transient Protection	Provided
Reverse Polarity Protection	Provided
Under-Voltage Protection	Provided (hardware shutdown at 8V)
Over-Voltage Protection	Provided (hardware shutdown at 38V)

Output

Output	<p>1 signal output selectable as: Voltage, Current, or PWM</p> <p>12-bit digital to analog Protected against shorts to GND or +Vcc</p> <p><u>Voltage Types:</u> Resolution: 12-bit Maximum Load: 25 mA</p> <table border="1"> <thead> <tr> <th>Range (V)</th> <th>Accuracy (%)</th> </tr> </thead> <tbody> <tr> <td>0-5</td> <td>0.25</td> </tr> <tr> <td>0-10</td> <td>0.4</td> </tr> <tr> <td>±5</td> <td>0.25</td> </tr> <tr> <td>±10</td> <td>0.5</td> </tr> </tbody> </table> <p><u>Current Types:</u> Resolution: 12-bit Maximum Load: 500 Ω</p> <table border="1"> <thead> <tr> <th>Range (mA)</th> <th>Accuracy (%)</th> </tr> </thead> <tbody> <tr> <td>0-20</td> <td>0.5</td> </tr> <tr> <td>4-20</td> <td>0.2</td> </tr> </tbody> </table> <p><u>PWM Type:</u> PWM Duty Cycle: 0-100% Frequency Range: 0 Hz to 5 kHz Amplitude: 5 V or 12 V Maximum Load: 20 mA</p> <table border="1"> <thead> <tr> <th>Range (Hz)</th> <th>Accuracy (%)</th> </tr> </thead> <tbody> <tr> <td>0-500</td> <td>0.01</td> </tr> <tr> <td>501-1000</td> <td>0.08</td> </tr> <tr> <td>1001-5000</td> <td>0.4</td> </tr> </tbody> </table>	Range (V)	Accuracy (%)	0-5	0.25	0-10	0.4	±5	0.25	±10	0.5	Range (mA)	Accuracy (%)	0-20	0.5	4-20	0.2	Range (Hz)	Accuracy (%)	0-500	0.01	501-1000	0.08	1001-5000	0.4
Range (V)	Accuracy (%)																								
0-5	0.25																								
0-10	0.4																								
±5	0.25																								
±10	0.5																								
Range (mA)	Accuracy (%)																								
0-20	0.5																								
4-20	0.2																								
Range (Hz)	Accuracy (%)																								
0-500	0.01																								
501-1000	0.08																								
1001-5000	0.4																								

General Specifications

Microcontroller	STM32H725RGV3; 32-bit, 1 Mbyte Flash Program Memory
Control Logic	Standard logic is provided
CAN Port	1 CAN (SAE J1939) 250 kbit/s, 500 kbit/s, 667 kbit/s, and 1 Mbit/s (Auto-baud-rate detection)
User Interface, Reflashing	Axiomatic Electronic Assistant KIT - P/N: AX070502 , or AX070506K
Compliance	RoHS, REACH
Vibration	Pending
Shock	Pending
Operating Conditions	-40 to 85°C (-40 to 185°F)
Storage Temperature	-50 to 125 °C
Weight	0.1 lbs. (0.0454 kg)
Protection	IP67
Enclosure and Dimensions	Plastic Enclosure, Nylon 6-6 with 30% glass fill Laser welded Integral connector equivalent to 6-pin TE Deutsch connector Refer to dimensional drawing.

Electrical Connections	<p>6-pin equivalent TE Deutsch connector P/N: DT04-6P A mating plug kit is available as Axiomatic P/N: AX070119 (includes 1 Plug DT06-6S, 6 Contacts 0462-201-16141, and 1 Wedgelock W6S)</p> <table border="1" data-bbox="548 348 984 604"> <thead> <tr> <th colspan="2">CAN and I/O Connector</th> </tr> <tr> <th>Pin #</th> <th>Description</th> </tr> </thead> <tbody> <tr> <td>1</td> <td>BATT+</td> </tr> <tr> <td>2</td> <td>BATT-</td> </tr> <tr> <td>3</td> <td>GND</td> </tr> <tr> <td>4</td> <td>Signal Output</td> </tr> <tr> <td>5</td> <td>CAN_L</td> </tr> <tr> <td>6</td> <td>CAN_H</td> </tr> </tbody> </table>	CAN and I/O Connector		Pin #	Description	1	BATT+	2	BATT-	3	GND	4	Signal Output	5	CAN_L	6	CAN_H
CAN and I/O Connector																	
Pin #	Description																
1	BATT+																
2	BATT-																
3	GND																
4	Signal Output																
5	CAN_L																
6	CAN_H																
Mounting	<p>Mounting holes sized for #8 or M4 bolts. The bolt length will be determined by the end-user's mounting plate thickness. The mounting flange of the controller is 0.17 inches (4.4 mm) thick.</p> <p>If the module is mounted without an enclosure, it should be mounted to reduce the likelihood of moisture entry. Install the unit with appropriate space available for servicing and for adequate wire harness access (6 inches or 15 cm) and strain relief (12 inches or 30 cm). The CAN wiring is considered intrinsically safe. The power wires are not considered intrinsically safe and so in hazardous locations, they need to be located in conduit or conduit trays at all times. The module must be mounted in an enclosure in hazardous locations for this purpose.</p> <p>All field wiring should be suitable for the operating temperature range of the module.</p>																

Dimensional Drawing

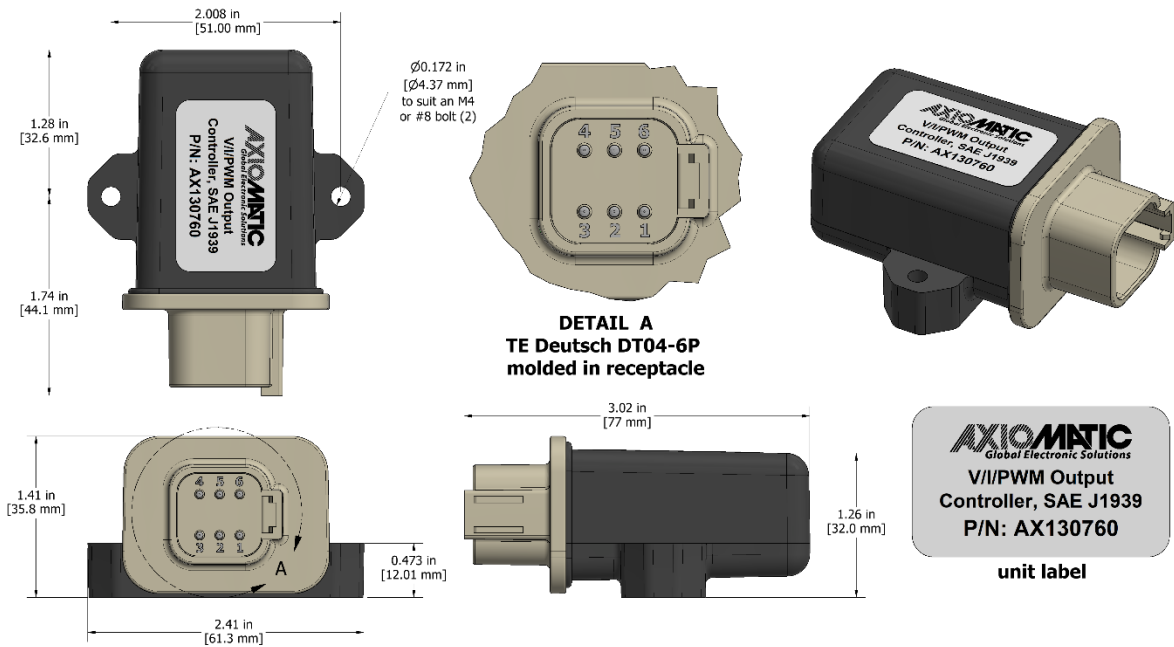

Form: TDAX130760-01/30/2024