

**Converts CAN messages into a PWM signal  
for communication with Control  
Modules**

**Features:**

- PWM Signal output to communicate with a control
- Output is user configurable as Frequency or digital
- 1 isolated CAN port (CANopen®) to read engine speed messages or other engine information
- Operational 9...36 Vdc (12 Vdc or 24 Vdc)
- Integrated, TE Deutsch equivalent 6-pin connector.
- Compact, fully sealed enclosure, IP67
- Meets the surge requirements of SAE J1445
- Designed for EMC compliance
- EDS provided to interface to standard CANopen® tools



**Applications:**

- Power Generator Set Control Systems

**Ordering Part Numbers:**

CAN-PWM Signal Converter, CANopen® - P/N: **AX130701**

Accessories:

EDS File

Mating Plug KIT: **AX070119**

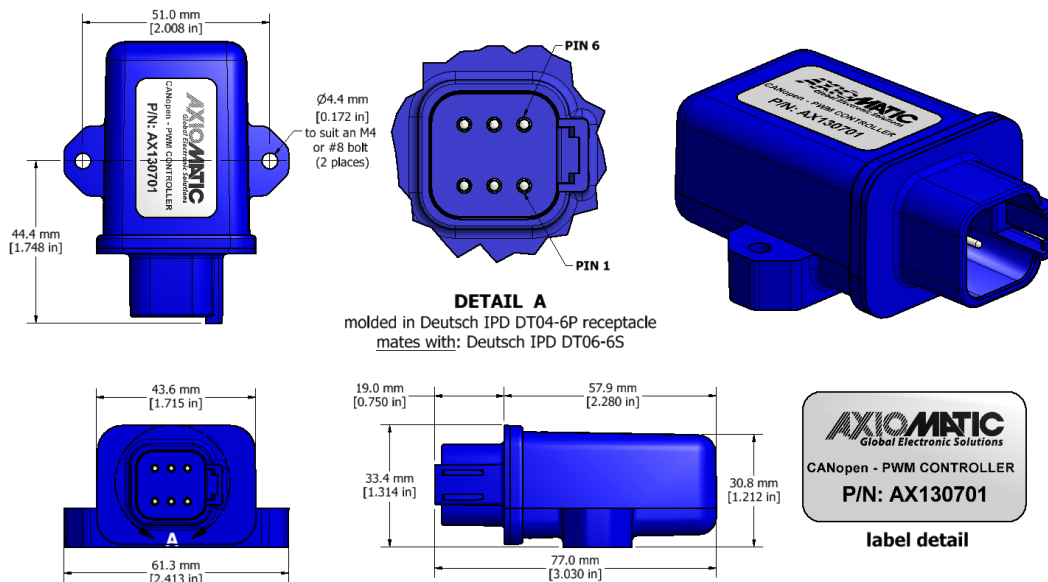

Figure 1.0 – Dimensional Drawing

## Technical Specifications:

Specifications are indicative and subject to change. Actual performance will vary depending on the application and operating conditions. Users should satisfy themselves that the product is suitable for use in the intended application. All our products carry a limited warranty against defects in material and workmanship. Please refer to our Warranty, Application Approvals/Limitations and Return Materials Process as described on <https://www.axiomatic.com/service/>.

### Power

Power Supply Input - Nominal	12 V or 24 Vdc nominal; 9...36 Vdc The minimum allowable supply voltage for the power pin is 7 Vdc.
Surge Protection	Meets the surge requirements of SAE J1445
Reverse Polarity Protection	Provided

### Output

Output	<p>1 Output configurable as PWM/Frequency or Digital PWM Signal, Frequency Signal or Mixed Output</p> <ul style="list-style-type: none"> <li>• 1 Hz to 20 kHz</li> <li>• 0-100% D.C. (User configurable)</li> <li>• 5V or 12V amplitude</li> <li>• Push pull output</li> <li>• Maximum load is 50 mA (at 5V) or 30 mA (at 12V).</li> <li>• Over-current protection (50 mA)</li> </ul> <p>Digital Level</p> <ul style="list-style-type: none"> <li>• Digital On/Off</li> <li>• 5V or 12V Amplitude</li> <li>• Maximum load is 50 mA (at 5V) or 30 mA (at 12V).</li> </ul> <p>Output feedback data available 2370h Output frequency (only) data available 2371h</p>
Error Detection/Reaction	EMCY code generation (object 1003h) and fault reaction is possible (1029h) when an out-of-range is flagged.
Output Accuracy	PWM Signal: 0.5%; Frequency Signal: 0.1%
Output Feedback Accuracy	PWM Signal: 0.5%; Frequency Signal: 0.5%

### Control Software

Software Platform	User programmable functionality using SDO object access, per CiA DS-301
-------------------	---

### General Specifications

Microcontroller	STM32F103CBT7; 32-bit, 128 Kbytes Flash Program Memory														
CAN Port	1 CAN (CANopen®)														
Isolation	300 Vrms isolation for CAN port														
Quiescent Current Draw	16 mA @ 24Vdc Typical														
Response Time	10 mSec. Typical														
Operating Temperature	-40 to 85°C (-40 to 185°F)														
Storage Temperature	-50 to 125°C (-58 to 257°F)														
Weight	0.15 lb. (0.068 kg)														
Protection Rating	IP67														
Vibration	MIL-STD-202G, Test 204D and 214A (Sine and Random) 10 g peak (Sine); 7.86 Grms peak (Random)														
Shock	MIL-STD-202G, Test 213B, 50 g														
Enclosure	Plastic Enclosure, Nylon 6-6 with 30% glass fill; Flammability Rating: UL 94V-0 Integral, TE Deutsch equivalent connector Refer to Figure 1.0, dimensional drawing.														
Electrical Connections	<p>6 pin TE Deutsch connector equivalent, P/N: DT04-6P A mating plug kit is available as Axiomatic P/N: <b>AX070119</b>.</p> <table border="1"> <thead> <tr> <th colspan="2">CAN and I/O Connector</th> </tr> <tr> <th>Pin #</th> <th>Description</th> </tr> </thead> <tbody> <tr> <td>1</td> <td>BATT+</td> </tr> <tr> <td>2</td> <td>Output +</td> </tr> <tr> <td>3</td> <td>CAN_H</td> </tr> <tr> <td>4</td> <td>CAN_L</td> </tr> <tr> <td>5</td> <td>Output -</td> </tr> </tbody> </table>	CAN and I/O Connector		Pin #	Description	1	BATT+	2	Output +	3	CAN_H	4	CAN_L	5	Output -
CAN and I/O Connector															
Pin #	Description														
1	BATT+														
2	Output +														
3	CAN_H														
4	CAN_L														
5	Output -														

	6	BATT-
User Interface	EDS provided to interface to standard CANopen® tools	

CANopen® is a registered community trademark of CAN in Automation e.V.

Form: TDAX130701-06/07/23