

Description: The wake-on charge module manages the vehicle controller power mode for wake and sleep. It has a charger status indication when the vehicle is plugged in (on charge). It is compliant with SAE J1772.

Application:

- Electric Vehicles



Ordering Part Numbers:

Wake-on-charge Module: **AX130601**

Accessories: **AX070112** (Comprised of DT06-8SA, W8S, 7 pcs. 0462-201-16141, 1 pc. 114017)

BLOCK DIAGRAM

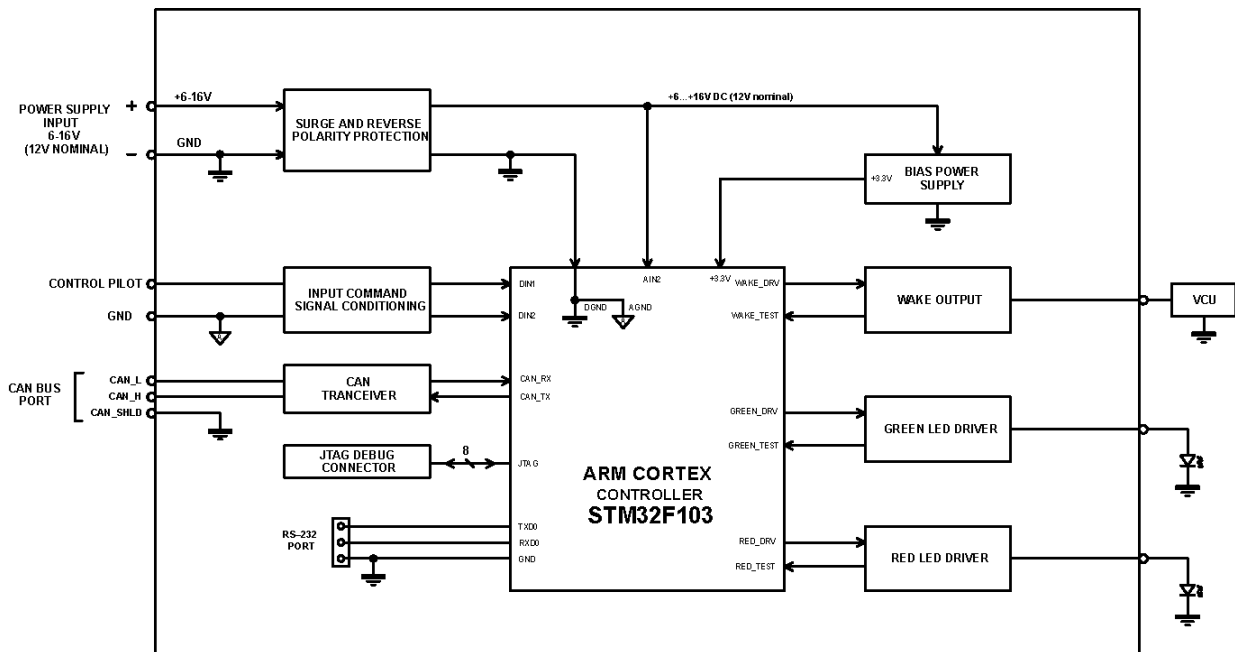

Technical Specifications:

Specifications are indicative and subject to change. Actual performance will vary depending on the application and operating conditions. Users should satisfy themselves that the product is suitable for use in the intended application. All our products carry a limited warranty against defects in material and workmanship. Please refer to our Warranty, Application Approvals/Limitations and Return Materials Process as described on <https://www.axiomatic.com/service/>.

Input Specifications

Power Supply Input	12VDC nominal (6...16 VDC power supply range)
Protection	It is designed to operate in typical automotive vehicle conditions such as jump start, double battery, load dump, alternator ripple, over-voltage, inductive switching, intermittent short circuit to battery and ground as well as reverse battery. The power line input should be fuse protected.
Input	<p>Accepts 1 Control Pilot Input Signal</p> <ul style="list-style-type: none"> • Detects when a Control Pilot signal is present and triggers the module to wake up within 100 ms. • Reads the PWM duty cycle of the Control Pilot Signal input (3-95% D.C.) from an EVSE • With a resolution of 0.5% and accuracy of 1%. • Impedance compatible with SAE J1772 Vehicle State B and C • SAE J1772 Vehicle States A, E and F are detectable <p>Note: The module wakes up when the vehicle is plugged in to an EVSE providing an SAE J1772-compatible Control Pilot signal (shared with the on-vehicle charger), drawing minimal current to ensure the vehicle's equivalent impedance stays within the standard's specified tolerance. (The standard is SAE Surface Vehicle Recommended Practice J1772, SAE Electric Vehicle Conductive Charge Coupler.)</p>

Output Specifications

Output	200 mA @12VDC (with a drop of 1VDC permitted) High side driver The output acts as the WAKE command to the Vehicle Control Unit or other controls/relay coils.
LED Output	2 LED outputs Up to 50 mA each The outputs are commanded over the CAN bus and they turn ON/OFF, change in brightness or FLASH a GREEN and a RED LED (not supplied) for charge port status indication. The 12V current draw of the module (operating and quiescent) is low enough to permit 72 hours of LED status indication.

General Specifications

Microprocessor	STM32 32-bit, 128 KByte flash program memory															
Control Logic	<p>Standard embedded software is provided. It performs the following functions.</p> <ul style="list-style-type: none"> • Module Wake/Sleep • VCU Wake/Sleep • Delayed Module Sleep/VCU Re-wake • Control of power mode • LED Control (separately) • Status Feedback over CAN of all inputs and outputs <p>The primary function of the module is to wake the Vehicle Control Unit (VCU) and control status LED's for the charger when the vehicle is plugged in to charge. The on-vehicle charger shares the Control Pilot signal input with the Wake-on-charge module. This input wakes up the Wake-on-charge module which in turn enables an output to wake the VCU. Control of the LED output drivers is in response to CAN messages from the VCU. When the VCU is ready to shut down the following can occur. The LEDs are controlled by the last received settings from the VCU command and the Wake-on-charge module will either sleep or re-wake the VCU after a controlled timer delay or if the 12VDC battery input voltage goes below a controlled threshold. Removal of the Control Pilot input signal after the VCU goes to sleep also sends the Wake-on-charge module to sleep.</p> <p>The unit ships with factory defaults. The end user must configure the unit for their application.</p>															
CAN	1 CAN 2.0 B port; 500 kbps baud rate; 11-bit ID															
User Interface	Diagnostics, programming and calibration is performed with a toolset compatible with Kvaser Leaf Light Rugged CAN-USB hardware.															
Quiescent Current Draw	<p>Refer to Table 1.0 below.</p> <p>Table 1.0: Quiescent Currents</p> <table border="1"> <thead> <tr> <th></th> <th>I_{q1} (mA)</th> <th>I_{q2} (mA)</th> <th>I_{q3} (mA)</th> <th>I_{q4} (mA)</th> </tr> </thead> <tbody> <tr> <td>Minimum</td> <td>228</td> <td>26</td> <td>1.05</td> <td>0.97</td> </tr> <tr> <td>Maximum</td> <td>233</td> <td>27.9</td> <td>1.20</td> <td>1.08</td> </tr> </tbody> </table>		I _{q1} (mA)	I _{q2} (mA)	I _{q3} (mA)	I _{q4} (mA)	Minimum	228	26	1.05	0.97	Maximum	233	27.9	1.20	1.08
	I _{q1} (mA)	I _{q2} (mA)	I _{q3} (mA)	I _{q4} (mA)												
Minimum	228	26	1.05	0.97												
Maximum	233	27.9	1.20	1.08												

	<table border="1"> <tr> <td>Average</td> <td>231.7</td> <td>29.96</td> <td>1.097</td> <td>1.010</td> </tr> </table> <p> I_{q1}: Current draw with module ON and load turned ON I_{q2}: Current draw with only module ON I_{q3}: Current draw during sleep mode with Pilot ON I_{q4}: Current draw during sleep mode with Pilot OFF </p>	Average	231.7	29.96	1.097	1.010
Average	231.7	29.96	1.097	1.010		
Diagnostics	<p>Diagnostics are supported. The module is configured to send status feedback messages over CAN. These messages include:</p> <ul style="list-style-type: none"> • LED 1 and 2 Status (off, on solid, flashing or not available) • Wake Output Status (off, on, error or not available) • Control Pilot Input Status (off, on, error or not available) • CPI duty cycle • CPI Frequency • EVSE Vehicle State • Elapsed wake on charge module on time (1 min resolution) • Battery voltage (1 mV resolution) 					
Weight	0.65 lbs. (0.29 kg)					
Operating Conditions	<p>Outside ambient air: -40 to 50 °C (-40 to 122 °F) Under hood: -40 to 85 °C (-40 to 185 °F)</p>					
Storage Temperature	-40 to 85 °C (-40 to 185 °F)					
Protection	IP67 rating for the product assembly					
Packaging	<p>Encapsulated Cast Aluminum housing with mounting holes Refer to dimensional drawing. 4.62 x 1.91 x 1.76 inches (117.30 x 48.56 x 44.73 mm) L x W x H including integral connector</p>					

Dimensional Drawing

(NB. AX130601 has the same dimensions as AX130600 shown.)

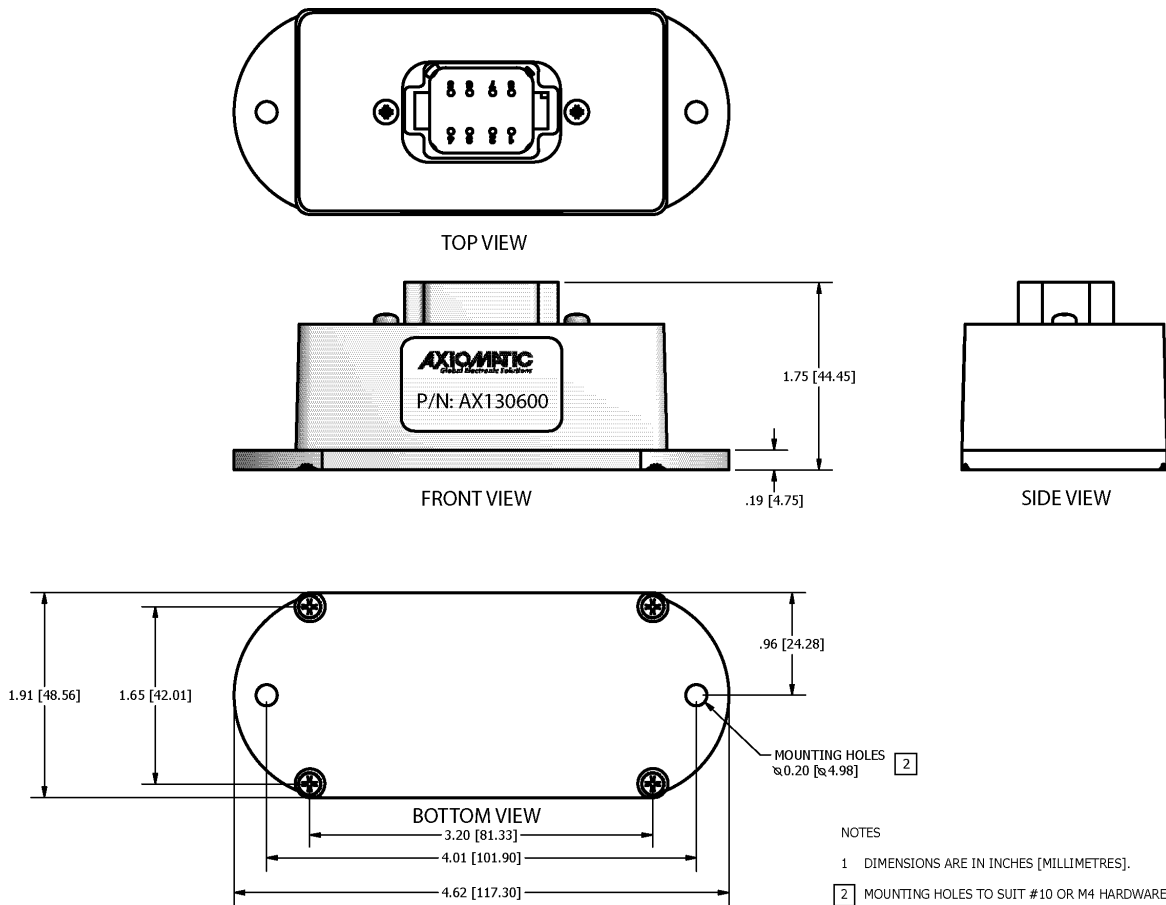

Compliance	<p>The module is designed to operate in an under-hood automotive environment per GMW 3172, Ford EY-0128/CETP 00.00-E-412, Ford ES-XW7T-1A278-AC, SAE J1455, IEC/EN 60529 and ISO 16750. The module meets "Class A" functional requirements as found in these standards.</p> <p>The module was designed to meet automotive EMC requirements. EMC testing was performed at the system level and results are not available at the component level. The module is designed to handle electrostatic discharge (ESD) as per GMW 3100/3097.</p>																		
Mounting	<p>Mounting holes – The controller accepts 2 #10 or M4 screws.</p> <p>The CAN wiring is considered intrinsically safe. The power wires are not considered intrinsically safe and so in hazardous locations, they need to be located in conduit or conduit trays at all times. The module must be mounted in an enclosure in hazardous locations for this purpose.</p> <p>All field wiring should be suitable for the operating temperature range.</p> <p>Install the unit with appropriate space available for servicing and for adequate wire harness access (6 inches or 15 cm) and strain relief (12 inches or 30 cm).</p>																		
Network Termination	<p>It is necessary to terminate the network with external termination resistors. The resistors are 120 Ohm, 0.25W minimum, metal film or similar type. They should be placed between CAN_H and CAN_L terminals at both ends of the network.</p>																		
Electrical Connections	<div data-bbox="542 716 1377 1062" data-label="Diagram"> </div> <p>8 pin plug (equivalent TE Deutsch P/N: DT15-8PA)</p> <p>Mating plug KIT: Axiomatic P/N AX070112 (Comprised of the following TE Deutsch P/N equivalents: DT016-8SA socket, wedge W8S, 7 solid contact sockets 0462-201-16141 and 1 sealing plug 114017.)</p> <p>16-18 AWG wire is recommended for use with sockets 0462-201-16141.</p> <p>Use dielectric grease on the pins when installing the controller.</p> <p>Wiring to these mating plugs must be in accordance with all applicable local codes. Suitable field wiring for the rated voltage and current must be used. The rating of the connecting cables must be at least 70°C. Use field wiring suitable for both minimum and maximum ambient temperature.</p> <table border="1" data-bbox="542 1419 912 1684"> <thead> <tr> <th>PIN #</th> <th>Name</th> </tr> </thead> <tbody> <tr> <td>1</td> <td>BATT+</td> </tr> <tr> <td>2</td> <td>LED1+</td> </tr> <tr> <td>3</td> <td>LED 2+</td> </tr> <tr> <td>4</td> <td>WAKE +</td> </tr> <tr> <td>5</td> <td>CAN_H</td> </tr> <tr> <td>6</td> <td>CAN_L</td> </tr> <tr> <td>7</td> <td>CTRL-PILOT-IN</td> </tr> <tr> <td>8</td> <td>BATT-</td> </tr> </tbody> </table>	PIN #	Name	1	BATT+	2	LED1+	3	LED 2+	4	WAKE +	5	CAN_H	6	CAN_L	7	CTRL-PILOT-IN	8	BATT-
PIN #	Name																		
1	BATT+																		
2	LED1+																		
3	LED 2+																		
4	WAKE +																		
5	CAN_H																		
6	CAN_L																		
7	CTRL-PILOT-IN																		
8	BATT-																		

Form: TDAX130601-06/09/23