

ISOLATED, DUAL CHANNEL UNIVERSAL SIGNAL CONVERTER

Configurable with Android Application
CAN (SAE J1939)

P/N: AX130540

Features:

- Four-way isolation between inputs, outputs, power and CAN bus
- SAE J1939 CAN port with auto-baud-rate detect.
- Two universal signal inputs are selectable as the following voltage or current signals:
 - 0-5V, 0-10V, 0 to +/- 5V, 0 to +/- 10V;
 - 4-20mA, 0-20mA, or 0-200 mA;
 - Resistive;
 - PWM;
 - Frequency;
 - or Digital.
- Magnetic Pick Up Input
- Encoder Input
- Two universal signal outputs are configurable as the following signals:
 - Analog voltage (0-5V, 0-10V, +/-5V, or +/- 10V);
 - Analog current (4-20 mA, 0-20 mA);
 - or PWM.
- 12Vdc or 24Vdc nominal
- One reference voltage (+5V) is available to power sensors.
- Operates from -40 to 85°C (-40 to 185°F).
- Two LED indicators
- IP20
- DIN rail mount
- CE/UKCA marking pending
- Configurable via the Axiomatic Electronic Assistant
- The firmware was developed using Simulink®.
- A Near Field Communications Antenna is provided for configuration using an Android Smartphone:
 - Place the phone next to the antenna and configure while unpowered.
 - The E-Write NFC Android Application provides flexible user configurability for application-specific input-output relationship with slope or time response.
 - Protected and secure communications



Applications:

- Industrial control panels
- Power gen set engine control systems
- Oil and gas equipment automation
- Off-highway machine automation

Ordering Part Numbers:

Isolated Dual Channel Universal Signal Converter, SAE J1939, auto-baud-rate detect: **AX130540**

Accessories:

Axiomatic Electronic Assistant KIT, P/N: **AX070502**, **AX070505K**, or **AX070506K**

Description: The isolated dual channel universal signal converter accepts two universal signal inputs and converts them into two signal outputs (analog voltage, analog current or digital signal). A magnetic pick up sensor and encoder inputs are also supported. The control can be networked to a SAE J1939 networked engine control system. The unit has 4-way isolation between power, inputs, outputs and CAN. Using the Axiomatic Electronic Assistant programming tool, the user can select the desired two inputs from the following signal options:

- 0-5 V, 0-10 Vdc, +/- 5 Vdc, or +/- 10 Vdc
- 4-20 mA, 0-20 mA or 0-200 mA
- 20 Ohms to 250 kOhm
- Frequency/RPM
- PWM
- or Digital (Active High or Active Low)

A +5V, 50 mA reference is available to power a sensor input. The outputs can also be programmed as 0-5 Vdc, 0-10 Vdc, +/- 5 Vdc, +/- 10 Vdc, 0-20 mA, 4-20 mA, or PWM signals. A rugged power supply interface accepts 12 Vdc or 24 Vdc nominal for battery powered machine applications. LED's indicate operational status. The enclosure is DIN rail mount. It operates from -40 to 85°C (-40 to 185°F). Standard embedded software is provided and is configurable using the Axiomatic Electronic Assistant (EA). Any of the outputs can be configured to use any of the inputs either as a control signal or an enable signal as well as use the CAN network data. The user can configure the control logic using configurable Function Blocks. The sophisticated control algorithms allow the user to program the controller for a wide range of applications without the need for customer software.

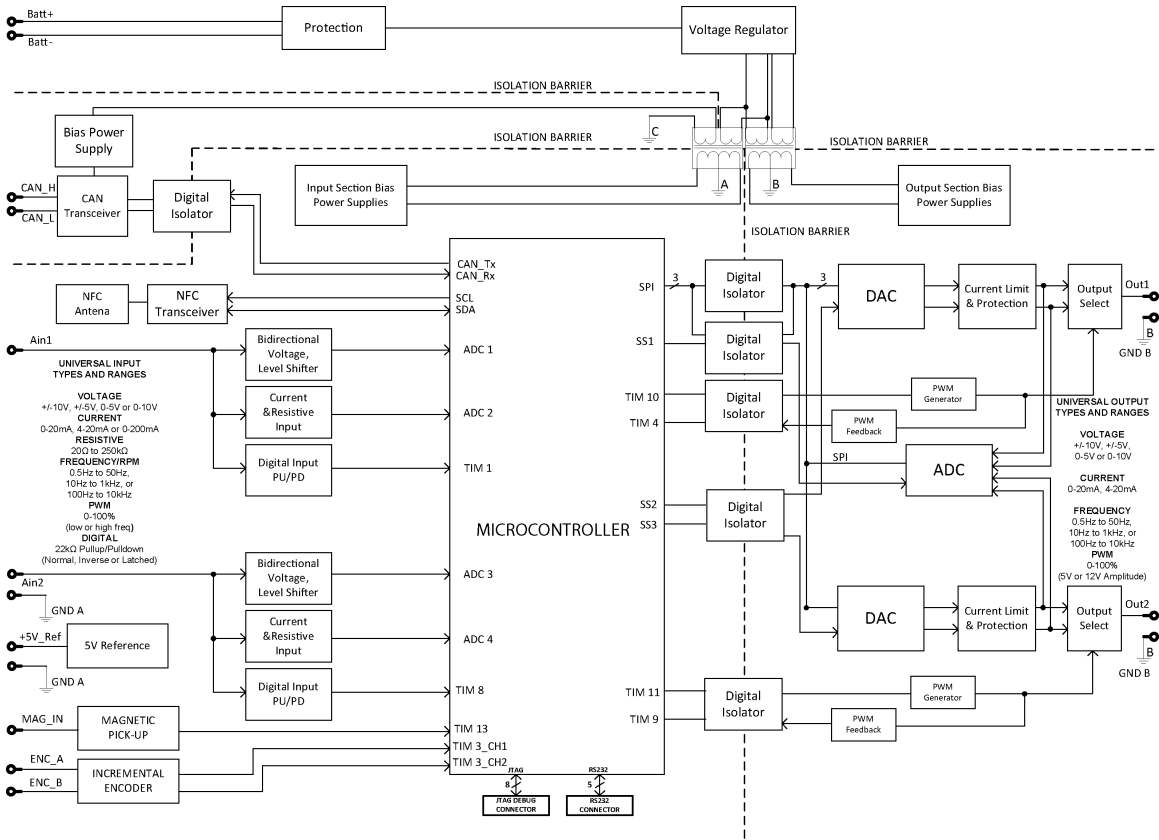

Figure 1.0 – Block Diagram

Technical Specifications:

Specifications are indicative and subject to change. Actual performance will vary depending on the application and operating conditions. Users should satisfy themselves that the product is suitable for use in the intended application. All our products carry a limited warranty against defects in material and workmanship. Please refer to our Warranty, Application Approvals/Limitations and Return Materials Process as described on <https://www.axiomatic.com/service/>.

Power Supply

Power Supply Input	12 Vdc or 24 Vdc nominal 8...36 Vdc power supply range Shutdown voltage is 8.0 Vdc.
Protection	Reverse polarity protection Overvoltage protection is up to 45 V.

Inputs

Inputs	2 Universal Signal Inputs User programmable as Voltage, Current, Resistive, Frequency, RPM, PWM or Digital signal inputs types. Refer to Table 1.0. 1 Magnetic Pick Up Sensor Input 1 Encoder Input																																													
Magnetic Pick Up Sensor Input	Range: 0.5 Hz to 20 kHz Amplitude: 100 mV to 60 Vrms																																													
Encoder Input	One 2 phase, phase A and B, incremental encoder input. Range: 0.5 Hz to 150 kHz Amplitude: up to +Vsupply																																													
Input Grounds	1 provided																																													
Protection	All inputs are protected against short to GND. All inputs, except current inputs, are protected against shorts to Nominal Vps (36Vdc).																																													
Input Accuracy and Resolution	<table border="1"> <thead> <tr> <th>Input Type</th> <th>Input Range</th> <th>Accuracy</th> <th>Resolution</th> </tr> </thead> <tbody> <tr> <td rowspan="4">Voltage</td> <td>0-5V</td> <td>+/- 0.5%</td> <td>1 mV</td> </tr> <tr> <td>0-10V</td> <td>+/- 0.5%</td> <td>1 mV</td> </tr> <tr> <td>-5V to 5V</td> <td>+/- 0.5%</td> <td>1 mV</td> </tr> <tr> <td>-10V to 10V</td> <td>+/- 0.5%</td> <td>1 mV</td> </tr> <tr> <td rowspan="2">Current</td> <td>0(4)-20mA</td> <td>+/-1%</td> <td>1 µA</td> </tr> <tr> <td>0-200mA</td> <td>+/-1%</td> <td>1 µA</td> </tr> <tr> <td>Resistive</td> <td>30-250kΩ</td> <td>+/-1%</td> <td>1 Ω for lower ranges 1 kΩ for higher ranges</td> </tr> <tr> <td rowspan="3">Frequency</td> <td>10 Hz-50Hz</td> <td>+/-0.3%</td> <td>0.01 Hz</td> </tr> <tr> <td>10Hz-1kHz</td> <td>+/-0.3%</td> <td>0.1 Hz</td> </tr> <tr> <td>100Hz-10kHz</td> <td>+/-0.3%</td> <td>1 Hz</td> </tr> <tr> <td rowspan="2">PWM</td> <td>Low Frequency</td> <td>+/-0.1%</td> <td>0.01%</td> </tr> <tr> <td>High Frequency</td> <td>+/-0.1%</td> <td>0.01%</td> </tr> </tbody> </table>	Input Type	Input Range	Accuracy	Resolution	Voltage	0-5V	+/- 0.5%	1 mV	0-10V	+/- 0.5%	1 mV	-5V to 5V	+/- 0.5%	1 mV	-10V to 10V	+/- 0.5%	1 mV	Current	0(4)-20mA	+/-1%	1 µA	0-200mA	+/-1%	1 µA	Resistive	30-250kΩ	+/-1%	1 Ω for lower ranges 1 kΩ for higher ranges	Frequency	10 Hz-50Hz	+/-0.3%	0.01 Hz	10Hz-1kHz	+/-0.3%	0.1 Hz	100Hz-10kHz	+/-0.3%	1 Hz	PWM	Low Frequency	+/-0.1%	0.01%	High Frequency	+/-0.1%	0.01%
Input Type	Input Range	Accuracy	Resolution																																											
Voltage	0-5V	+/- 0.5%	1 mV																																											
	0-10V	+/- 0.5%	1 mV																																											
	-5V to 5V	+/- 0.5%	1 mV																																											
	-10V to 10V	+/- 0.5%	1 mV																																											
Current	0(4)-20mA	+/-1%	1 µA																																											
	0-200mA	+/-1%	1 µA																																											
Resistive	30-250kΩ	+/-1%	1 Ω for lower ranges 1 kΩ for higher ranges																																											
Frequency	10 Hz-50Hz	+/-0.3%	0.01 Hz																																											
	10Hz-1kHz	+/-0.3%	0.1 Hz																																											
	100Hz-10kHz	+/-0.3%	1 Hz																																											
PWM	Low Frequency	+/-0.1%	0.01%																																											
	High Frequency	+/-0.1%	0.01%																																											

Table 1.0 –User Programmable Universal Inputs																																																	
Analog & Digital Input Functions	Voltage Input, Current Input, Resistive Input or Digital Input																																																
Voltage Input	0-5 V (Impedance 110 kΩ) 0-10 V (Impedance 130 kΩ) +/- 5V (Impedance 110 kΩ) +/- 10V (Impedance 130 kΩ)																																																
Current Input	0-200 mA (Impedance 5 Ω); 1V max. 0-20 mA (Impedance 249 Ω) 4-20 mA (Impedance 249 Ω)																																																
Resistive	20 Ohms to 250 kOhms Self-calibrating																																																
Digital Input Level	Accepts 5 V TTL Accepts up to Vps Threshold: Low <1 V High >2.2 V																																																
Digital Input	1 M Ω Impedance or Active High or Active Low with 10 kOhm pull-up or pull-down																																																
Timer Input Functions	PWM Input, Frequency Input, RPM Input																																																
PWM Input	Low Frequency (10 Hz to 1 kHz) High Frequency (100 Hz to 10 kHz) 0 to 100% D.C.																																																
Frequency/RPM Input	0.5 Hz to 50 Hz; 10 Hz to 1 kHz; or 100 Hz to 20 kHz																																																
Maximum and Minimum Ratings	<table border="1"> <thead> <tr> <th>Characteristic</th> <th>Min</th> <th>Max</th> <th>Units</th> </tr> </thead> <tbody> <tr> <td>Power Supply</td> <td>9</td> <td>36</td> <td>V dc</td> </tr> <tr> <td>Voltage Input</td> <td>0</td> <td>36</td> <td>V dc</td> </tr> <tr> <td>Current Input 0(4)-20 mA</td> <td>0</td> <td>12</td> <td>Vdc</td> </tr> <tr> <td>Current Input 0-200 mA</td> <td>0</td> <td>1V</td> <td>Vdc</td> </tr> <tr> <td>Resistive Input</td> <td>30</td> <td>250 000</td> <td>Ω</td> </tr> <tr> <td>Digital Input</td> <td>0</td> <td>36</td> <td>Vdc</td> </tr> <tr> <td>PWM Duty Cycle</td> <td>0</td> <td>100</td> <td>%</td> </tr> <tr> <td>PWM Low Frequency</td> <td>10</td> <td>1 000</td> <td>Hz</td> </tr> <tr> <td>PWM High Frequency</td> <td>100</td> <td>10 000</td> <td>Hz</td> </tr> <tr> <td>PWM Voltage pk - pk</td> <td>0</td> <td>36</td> <td>V dc</td> </tr> <tr> <td>RPM Frequency</td> <td>0.5</td> <td>20 000</td> <td>Hz</td> </tr> </tbody> </table>	Characteristic	Min	Max	Units	Power Supply	9	36	V dc	Voltage Input	0	36	V dc	Current Input 0(4)-20 mA	0	12	Vdc	Current Input 0-200 mA	0	1V	Vdc	Resistive Input	30	250 000	Ω	Digital Input	0	36	Vdc	PWM Duty Cycle	0	100	%	PWM Low Frequency	10	1 000	Hz	PWM High Frequency	100	10 000	Hz	PWM Voltage pk - pk	0	36	V dc	RPM Frequency	0.5	20 000	Hz
Characteristic	Min	Max	Units																																														
Power Supply	9	36	V dc																																														
Voltage Input	0	36	V dc																																														
Current Input 0(4)-20 mA	0	12	Vdc																																														
Current Input 0-200 mA	0	1V	Vdc																																														
Resistive Input	30	250 000	Ω																																														
Digital Input	0	36	Vdc																																														
PWM Duty Cycle	0	100	%																																														
PWM Low Frequency	10	1 000	Hz																																														
PWM High Frequency	100	10 000	Hz																																														
PWM Voltage pk - pk	0	36	V dc																																														
RPM Frequency	0.5	20 000	Hz																																														

Outputs

Outputs	<p>2 Isolated Universal Signal Outputs Voltage, Current or PWM The outputs are user selectable as follows. Refer to Table 2.0.</p> <table border="1"> <thead> <tr> <th colspan="2">Table 2.0: Programmable Outputs</th> </tr> </thead> <tbody> <tr> <td>Analog Voltage or Current Outputs:</td> <td> <u>Voltage Output:</u> 0-5 Vdc, 0-10 Vdc, +/- 5Vdc or +/- 10Vdc Maximum load is 50 mA. <u>Current Output:</u> 0-20 mA or 4-20 mA Maximum load resistance is < 500 Ohms. Compliance Voltage is 10V. </td> </tr> <tr> <td>PWM, Frequency or Mixed PWM/Frequency Output:</td> <td>0.1 Hz to 20 kHz 0-100% D.C. 5 V or 12 V Amplitude Push pull output Maximum load is 50 mA. Over-current protection (50 mA)</td> </tr> <tr> <td>Digital Output:</td> <td>Digital Level Digital ON/OFF 5 V or 12 V Amplitude Maximum load is 50 mA.</td> </tr> </tbody> </table>	Table 2.0: Programmable Outputs		Analog Voltage or Current Outputs:	<u>Voltage Output:</u> 0-5 Vdc, 0-10 Vdc, +/- 5Vdc or +/- 10Vdc Maximum load is 50 mA. <u>Current Output:</u> 0-20 mA or 4-20 mA Maximum load resistance is < 500 Ohms. Compliance Voltage is 10V.	PWM, Frequency or Mixed PWM/Frequency Output:	0.1 Hz to 20 kHz 0-100% D.C. 5 V or 12 V Amplitude Push pull output Maximum load is 50 mA. Over-current protection (50 mA)	Digital Output:	Digital Level Digital ON/OFF 5 V or 12 V Amplitude Maximum load is 50 mA.
Table 2.0: Programmable Outputs									
Analog Voltage or Current Outputs:	<u>Voltage Output:</u> 0-5 Vdc, 0-10 Vdc, +/- 5Vdc or +/- 10Vdc Maximum load is 50 mA. <u>Current Output:</u> 0-20 mA or 4-20 mA Maximum load resistance is < 500 Ohms. Compliance Voltage is 10V.								
PWM, Frequency or Mixed PWM/Frequency Output:	0.1 Hz to 20 kHz 0-100% D.C. 5 V or 12 V Amplitude Push pull output Maximum load is 50 mA. Over-current protection (50 mA)								
Digital Output:	Digital Level Digital ON/OFF 5 V or 12 V Amplitude Maximum load is 50 mA.								

Output Accuracy and Resolution	Output Type	Output Range	Output Accuracy	Output Resolution	Output Feedback Accuracy
	Voltage	0-5V	+/- 0.5%	1.2 mV	+/- 1%
		0-10V	+/- 0.5%	2.44 mV	+/- 1%
		+/- 5Vdc	+/- 0.5%	2.44 mV	+/- 1%
		+/- 10Vdc	+/- 0.5%	4.88 mV	+/- 1%
	Current	0(4)-20mA	+/- 0.5%	4.88 μ A	+/- 2%
	Digital	On/Off	N/A	N/A	N/A
	Frequency	10 Hz-50kHz	+/- 0.1%	0.01 – 40 Hz	+/- 0.5%
	PWM	Low Frequency	+/- 0.5%	0.01%	+/- 0.8%
High Frequency		+/- 0.5%	0.01%	+/- 0.8%	
Voltage Reference	+5V, +/- 0.5%, 50 mA Ground is shared with Input Grounds.				
Protection for Output Terminals	Fully protected against short circuit to output ground. Unit will fail safe in the case of a short circuit condition, self-recovering when the short is removed.				

General Specifications

Microcontroller	STM32F205VGT7 32-bit, 1MByte flash memory
Isolation	300 Vrms 4-way Digital Isolation (Power, Inputs, Outputs and CAN are isolated from each other.)
Typical Quiescent Current	125 mA@ 12Vdc; 65 mA @ 24Vdc typical
Response Time	30 mSec.
LED Indicators	2 bicolour LED's (Red and Green) Power, heartbeat, input fault indication and output fault indication
CAN Communications	1 Isolated CAN port (SAE J1939) (CANopen® on request)
Baud Rate	250kbit/s, 500kbit/s, 667kbit/s, 1Mbit/s. Automatic Baud Rate Detection
Control Logic	<p>Standard embedded software is provided and is configurable using the Axiomatic Electronic Assistant (EA). Any of the outputs can be configured to use any of the inputs either as a control signal or an enable signal as well as use the CAN network data. The user can configure the control logic using the following Function Blocks.</p> <p>For more details on control logic, refer to the User Manual.</p> <ul style="list-style-type: none"> • The Input Function Block allows the user to configure the input type. Normal, inverse and latched options are available for Universal and Digital input types. Pull-up or Pull-down resistors can be enabled or disabled for Frequency, PWM or Digital Input types. Frequency/RPM or PWM input types have a Debounce setpoint to select an input capture filter. Digital inputs can be configured as Active High or Active Low. Minimum and maximum range setpoints define the range of the signal input as a control source. Input filtering is selectable. • The Output Function Block allows for selection of each output type or output disable. Various setpoints by output type can be configured. Refer to the output specification and the user manual. • The Constant Data Function Block allows for a list of constant data values to be used by the other function blocks. The Axiomatic EA configures the constant data points. • The Variable Data Function Block allows for measured process parameters to be stored in a variable memory. • The Diagnostic Function Block supports SAE J1939 DM1, DM2, DM3, DM11 messages. Fault diagnostics are not available for the digital input types. In addition to input/output faults, the controller can detect and react to power supply fault, over temperature fault and communication fault. • The Simplified Lookup Table Function Block is used to give output response up to 3 slopes per input. If more than 3 slopes are needed, then the Programmable Logic Function Block is used to combine up to 2 tables to generate more slopes. This is a powerful tool. Up to 2 different responses to the same input or three different responses to different inputs can become the input to another function block. • The PID Control Function Block has a user configurable input and reference signals and the output of the PID block can drive any of the other function blocks. • Simple Math Function Blocks allow the user to define basic algorithms. Each block can take up to 2 input signals and performs one function which is then

	<p>scaled according to an associated limit and scaling setpoints.</p> <ul style="list-style-type: none"> • The Simplified Timer Function Block allows the user to toggle between two signal sources for a user configurable delay time. • The Hysteresis Block implements hysteresis with user configurable transition thresholds. • The Set-Reset Block implements Set-Reset logic with user configurable Set and Reset sources. • The Simple Conditional Blocks implement conditional logic using up to 4 signal sources. • The DTC React Function Block allows for a received DTC from another device on the CAN network to disable an output or act as an input to a function block. • The CAN Transmit Function Block sends any output from another function block to the CAN network. Each CAN Transmit Message has several setpoints. Refer to the User Manual for details. By default, all messages are sent on Proprietary B PGN's as broadcast messages. • The CAN Receive Message Function Block is designed to take any SPN from the CAN network and use it as an input to another function block. The Axiomatic EA will allow for the selection of any ECN Address from 0 to 253 (default is 128). <p>Setpoint configuration files can be saved and used to program additional controllers. (Application-specific control logic is available on request.)</p>
NFC Communications	<p>Near Field Communication Full-duplex Data rate: 106 kbit/s Complies with ISO1443 (RF protocol), ISO13239, and ISO7816 Protected and secure configuration</p>
User Interface	E-WRITE NFC Application is available from the Google Play Store for simple configurations.
Software Reflashing	Axiomatic Electronic Assistant KIT, P/N: AX070502, AX070505K, or AX070506K
User Interface	<p>To configure the controller for sophisticated control applications, the AX130540 setpoints can be viewed and programmed using the standard J1939 memory access protocol through the CAN port and the PC-based Axiomatic Electronic Assistant. The Axiomatic EA can store all setpoints in one setpoint file and then flash them into the unit in one operation. The setpoint file is created and stored on disk using a command <i>Save Setpoint File</i> from the EA menu or toolbar. The user then can open the setpoint file, view or print it and flash the setpoint file into the AX130540.</p> <p>The Axiomatic Electronic Assistant KIT, P/N: AX070502, AX070505K, or AX070506K, for <i>Windows</i> operating systems comes with a royalty-free license for use on multiple computers. It includes an Axiomatic USB-CAN converter to link the device's CAN port to a <i>Windows</i>-based PC.</p>
Vibration	IEC 60068-2-6: 2007-12 (Sine), 2 g peak (Sine)
Shock	IEC 60068-2-27: 2008-02, 15 g
Operating Conditions	-40 to 85 °C (-40 to 185 °F)
Storage Temperature	-55 to 125 °C (-67 to 257°F)
Protection	IP20
Weight	0.30 lb. (0.136 kg)
Enclosure and Dimensions	<p>Phoenix Contact: ME MAX 22,5 G 2-2 KMGY – 2713638 Polyamide, flammability rating UL94V0, cULus recognized, China RoHS DIN rail TH 35-7.5</p> <p>99 x 114.5 x 22.5 x 99 mm (L x H x W x D) Refer to Figure 2.0.</p>
Electrical Connections	<p>4 Phoenix Contact PSPT 2,5/ 4-ST KMGY spring clamp connectors or 4 Phoenix Contact MSTBT2,5HC/4-STPGY screw terminals (based on availability) Accepts 24-14 AWG wire. Refer to Table 3.0 and Figure 2.0. for pin out.</p>
Installation	DIN rail mount TH 35-7.5
Network Termination	It is necessary to terminate the network with external termination resistors. The resistors are 120 Ohm, 0.25W minimum, metal film or similar type. They should be placed between CAN_H and CAN_L terminals at both ends of the network.

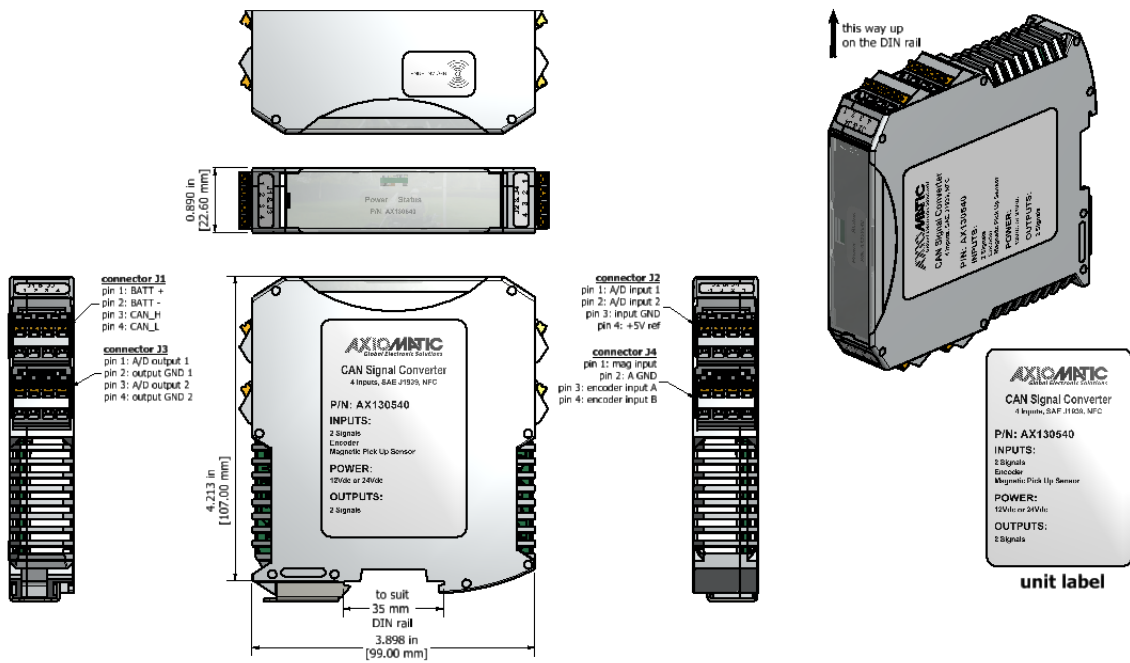

Figure 2.0 – Dimensions

Table 3.0 – Pin out: AX130540

Power and CAN (J1)		Outputs (J3)		Inputs (J2)		Reference and GNDs (J4)	
PIN #	Function	PIN #	Function	PIN #	Function	PIN #	
1	BATT +	1	Universal Output 1+	1	Universal Input 1	1	Magnetic Pick Up Input
2	BATT –	2	Output 1-	2	Universal Input 2	2	Common Analog GND
3	CAN_H	3	Universal Output 2+	3	Input GND	3	Encoder Input A
4	CAN_L	4	Output 2-	4	+5V Reference	4	Encoder Input B

CANopen® is a registered community trademark of CAN in Automation e.V.

Form: TDAX130540-05/26/23