

Dual Stepper Motor Controller

2 Universal Signal Inputs
 1 Encoder Interface
 2 Magnetic Pick-up Sensor Inputs
 2 Motor Outputs (2A)
 1 Universal Output (2.5A)
 12V or 24VDC
 +5V Reference
 1 CAN (SAE J1939)
 with the Axiomatic Electronic Assistant
 P/N: AX100750

Features:

- Two independent outputs for stepper motors
- Simple and accurate control of the levels, waveforms, timing and phase-shifts of the current for a two-phase stepper motor via SAE J1939 command messages
- 2 Universal inputs for voltage, current, frequency or PWM (user selectable) can act as a command source for a run-time parameter, feedback in a PID control loop or as an E-stop command
- +5V reference voltage to power a sensor or potentiometer
- 1 Encoder Input
- 2 Magnetic sensor inputs for inductive or active sensors (user selectable)
- 12V/24VDC input power (nominal)
- Surge protection, over and under voltage protection
- Motor output is 2A per phase for two Stepper Motors.
- Motor direction is selectable
- 1 universal (proportional current, voltage, digital), sinking or sourcing output (up to 2.5A) for a valve, relay, brake or other load
- 1 isolated CAN (SAE J1939) port, auto-baud-rate detection
- CANopen® module available on request
- Open or closed loop motor drive control logic (user selectable)
- Fault detection over CAN bus
- Highly programmable to meet various application-specific requirements.
- The **Axiomatic Electronic Assistant** configures the device.
- Rugged packaging and connectors



Applications:

- Construction Equipment, Mobile Equipment, Material Transport Vehicles, On-road Vehicles (Bus)

Ordering Part Numbers:

Dual Stepper Motor Drive, SAE J1939: **AX100750**

Accessories:

Mating Plug Kit: **PL-DTM06-12SA-12SB**

Axiomatic Electronic Assistant Configuration KIT, P/Ns: **AX070502, AX070505K, or AX070506K**

Block Diagram

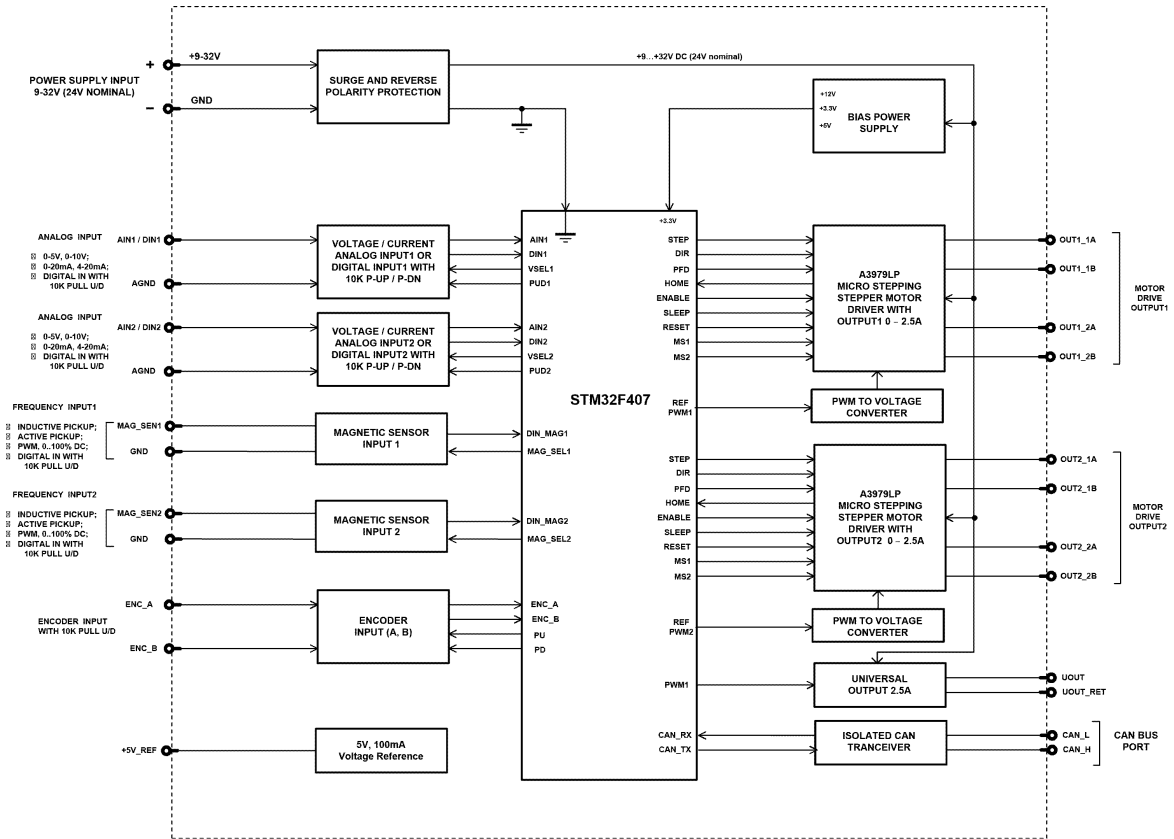

Technical Specifications:

Specifications are indicative and subject to change. Actual performance will vary depending on the application and operating conditions. Users should satisfy themselves that the product is suitable for use in the intended application. All our products carry a limited warranty against defects in material and workmanship. Please refer to our Warranty, Application Approvals/Limitations and Return Materials Process as described on <https://www.axiomatic.com/service/>.

Power Supply

Power Supply Input - Nominal	12V or 24Vdc nominal (9...32 Vdc power supply range) Maximum 8A at one time.
Reverse Polarity Protection	Provided
Surge Protection	Provided
Under-voltage Protection	Provided, software reaction
Over-voltage Protection	Provided, software reaction

Input Specifications

<p>Universal Inputs</p>	<p>2 Universal Inputs Selectable as: Voltage, Current, PWM or Digital types Protected against shorts to GND or +Vcc</p> <table border="1" data-bbox="591 281 1372 831"> <tr> <td data-bbox="591 281 808 457"> <p>Analog Input</p> </td> <td data-bbox="808 281 1372 457"> <p>Analog input, user configurable</p> <ul style="list-style-type: none"> • Voltage: 0-5V; 0-10V (Impedance 204 KOhm) • Current: 4-20 mA; 0-20 mA • Current sense resistor 124Ω <p>Inputs are sampled every 1 msec. Accuracy: +/- 0.5% over range Resolution: 1mV or 1uA, depending on type</p> </td> </tr> <tr> <td data-bbox="591 457 808 831"> <p>Digital Input</p> </td> <td data-bbox="808 457 1372 831"> <p>Digital input, user configurable for inductive or active sensors</p> <ul style="list-style-type: none"> • Digital • Frequency • PWM <p>Can be configured as active high or low digital input Digital Input: Active High to Supply or Active Low to GND Amplitude: 3.3V to +Supply User configurable for sampling range: 1 – 10,000 Hz PWM Duty Cycle: 0 to 100% Inputs are sampled every 1 msec. Accuracy: +/- 1% over range Resolution: 0.01 Hz or 0.1 Hz or 1Hz, depending on measuring range. 0.01% for PWM input Frequency/PWM @ 10 KOhm pullup or pulldown</p> </td> </tr> </table>	<p>Analog Input</p>	<p>Analog input, user configurable</p> <ul style="list-style-type: none"> • Voltage: 0-5V; 0-10V (Impedance 204 KOhm) • Current: 4-20 mA; 0-20 mA • Current sense resistor 124Ω <p>Inputs are sampled every 1 msec. Accuracy: +/- 0.5% over range Resolution: 1mV or 1uA, depending on type</p>	<p>Digital Input</p>	<p>Digital input, user configurable for inductive or active sensors</p> <ul style="list-style-type: none"> • Digital • Frequency • PWM <p>Can be configured as active high or low digital input Digital Input: Active High to Supply or Active Low to GND Amplitude: 3.3V to +Supply User configurable for sampling range: 1 – 10,000 Hz PWM Duty Cycle: 0 to 100% Inputs are sampled every 1 msec. Accuracy: +/- 1% over range Resolution: 0.01 Hz or 0.1 Hz or 1Hz, depending on measuring range. 0.01% for PWM input Frequency/PWM @ 10 KOhm pullup or pulldown</p>
<p>Analog Input</p>	<p>Analog input, user configurable</p> <ul style="list-style-type: none"> • Voltage: 0-5V; 0-10V (Impedance 204 KOhm) • Current: 4-20 mA; 0-20 mA • Current sense resistor 124Ω <p>Inputs are sampled every 1 msec. Accuracy: +/- 0.5% over range Resolution: 1mV or 1uA, depending on type</p>				
<p>Digital Input</p>	<p>Digital input, user configurable for inductive or active sensors</p> <ul style="list-style-type: none"> • Digital • Frequency • PWM <p>Can be configured as active high or low digital input Digital Input: Active High to Supply or Active Low to GND Amplitude: 3.3V to +Supply User configurable for sampling range: 1 – 10,000 Hz PWM Duty Cycle: 0 to 100% Inputs are sampled every 1 msec. Accuracy: +/- 1% over range Resolution: 0.01 Hz or 0.1 Hz or 1Hz, depending on measuring range. 0.01% for PWM input Frequency/PWM @ 10 KOhm pullup or pulldown</p>				
<p>Encoder Input</p>	<p>1 2-phase, phase A and B, incremental encoder input 1MΩ Impedance or Active High with 10K Pullup or Active Low with 10K Pulldown resistor to GND Range: 0.5 to 150 kHz Amplitude: up to +Supply</p>				
<p>Magnetic Pick-up Inputs</p>	<p>2 Pulse or PWM inputs, for inductive or active sensors Frequency Range: 0.5 Hz to 10 kHz Can be configured as active high or low digital input Protected against shorts to GND or +Vcc</p>				
<p>Signal Grounds</p>	<p>2 Analog GND (Input and +5Vref) 1 Magnetic Pick-up GND</p>				

Output Specifications

Outputs to Motors	Two (2) independent outputs for stepper motors Allegro DMOS Microstepping Driver, A3979 Maximum 2A per phase for a Stepper Motor Overcurrent protection is provided by the driver up to 2.5A. User has full access to all the driver features via CAN messages.
Motor Disable	Motor can be disabled in a variety of ways, including "Motor Mode", and "E-Stop" input, or when an error is detected.
Motor Direction	Motor Direction can be user selected for Clockwise or Counter-Clockwise Drive. Refer to the User Manual for details.
Thermal Protection	Thermal protection is built-in to driver chip.
Output	One output selectable as: Proportional Current; Hotshot Digital; PWM Duty Cycle; Proportional Voltage; or On/Off Digital Half-bridge output, current sensing, High-side or Low-side load High side sourcing or low side sinking up to 2.5A Overcurrent protection Short circuit protection in hardware Current Output: Accuracy +/- 1% error Voltage Output: Accuracy +/- 5% error High frequency drive PWM Output: 0.1% resolution, accuracy +/- 0.1% error Digital On/Off: Sourcing from power supply or sinking to ground Load at supply voltage must not draw more than 2.5A. Note: Output 1 has dedicated E-Stop Brake hardware protection function.
Reference Voltage	+5V, 50 mA is available to power a sensor or potentiometer and is referenced to Analog GND

General Specifications

Microprocessor	STM32F407VGT7
Isolation	1 Isolated CAN port 200Vrms isolation from power supply
CAN Port	1 SAE J1939 port, auto-baud-rate detection
Motor Drive Logic	Standard embedded software is provided. The stepper drive is a highly programmable controller, allowing the user to configure it for their application. Its sophisticated control algorithms allow for open or closed loop drive of the motor. All I/O on the unit are inherently independent from one another but can be programmed to interact in many ways. All configurable parameters are user selectable using the Axiomatic Electronic Assistant. There are 2 types of function blocks associated with the stepper motor logic and drive. <u>Stepper Drive Values</u> : Default run-time values, ranges for linear controls <u>Stepper Drive Controls</u> : Selection of control sources for all the run-time variables associated with the stepper and output drive Up to 15 independent CAN Receive messages can be read from a J1939 network to control the various run-time variables associated with the stepper drive. Up to 10 independent CAN Transmit messages can be sent to a J1939 network for system diagnostics and feedback.
Diagnostics	Each input and output channel can be configured to send diagnostic messages to the CAN network if the I/O goes out of range. Diagnostic data is stored in a non-volatile log.
Additional Fault Feedback	There are several types of faults that the controller will detect and provide a response: phase current winding problems; power supply undervoltage and overvoltage; and lost communication. They can be sent to the CAN bus.
User Interface	Axiomatic Electronic Assistant KIT, P/Ns: AX070502, AX070505K, or AX070506K
Quiescent Current Draw	70 mA @ 12Vdc; 50mA @ 24Vdc typical
Weight	0.55 lbs. (0.25 kg)
Operating Conditions	-40 to 85 °C (-40 to 185 °F)
Storage Temperature	-55 to 125 °C (-67 to 257°F)
Protection	IP67, Unit is conformal coated in the housing.

Enclosure and Dimensions	High Temperature Nylon PCB Enclosure - (equivalent TE Deutsch P/N: EEC-325X4B) 4.62 x 5.24 x 1.43 inches 117.42 x 133.09 x 36.36 mm (W x L x H excluding mating plugs)
--------------------------	--

Dimensional Drawing

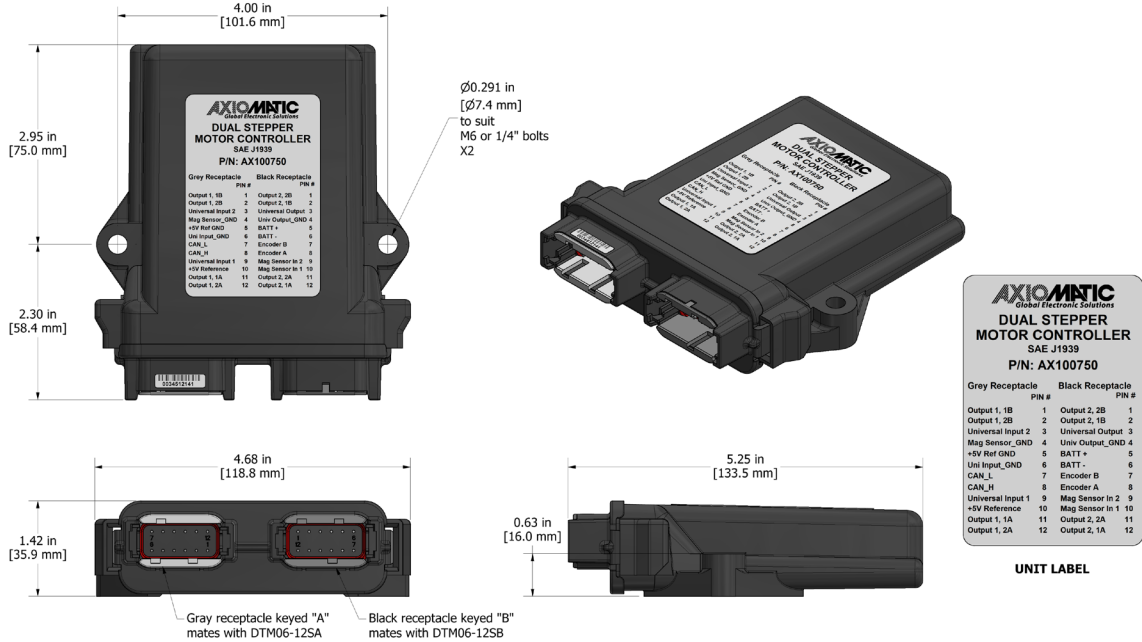

Mounting	<p>Mounting holes sized for 1/4 inch or M6 bolts. The bolt length will be determined by the end-user's mounting plate thickness. The mounting flange of the controller is 0.63 inches (16 mm) thick.</p> <p>If the module is mounted without an enclosure, it should be mounted vertically with connectors facing left and right to reduce likelihood of moisture entry.</p> <p>The CAN wiring is considered intrinsically safe. The power wires are not considered intrinsically safe and so in hazardous locations, they need to be located in conduit or conduit trays at all times. The module must be mounted in an enclosure in hazardous locations for this purpose.</p> <p>No wire or cable harness should exceed 30 meters in length. The power input wiring should be limited to 10 meters.</p> <p>All field wiring should be suitable for the operating temperature range.</p> <p>Install the unit with appropriate space available for servicing and for adequate wire harness access (6 inches or 15 cm) and strain relief (12 inches or 30 cm).</p>
Network Termination	It is necessary to terminate the network with external termination resistors. The resistors are 120 Ohm, 0.25W minimum, metal film or similar type. They should be placed between CAN_H and CAN_L terminals at both ends of the network.
Electrical Connections	<p>24-pin receptacle (equivalent TE Deutsch P/N: DTM13-12PA-12PB-R008)</p> <p>Mating plug - equivalent to the TE Deutsch P/Ns: DTM06-12SA and DTM06-12SB, with 2 wedgelocks (WM12S) and 24 contacts (0462-201-20141).</p> <p>20 AWG wire is recommended for use with contacts 0462-201-20141.</p> <p>Use dielectric grease on the pins when installing the controller.</p>

Connections

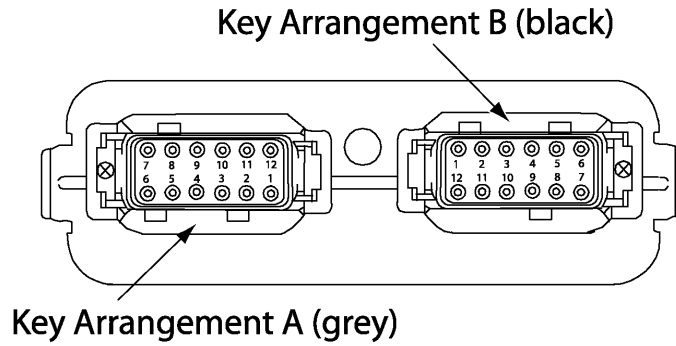

FRONT VIEW 24 PIN RECEPTACLE

Grey Connector		Black Connector	
Pin #	Function	Pin #	Function
1	Output 1, 1B	1	Output 2, 2B
2	Output 1, 2B	2	Output 2, 1B
3	Universal Input 2	3	Universal Output
4	Magnetic Sensor Input_GND	4	Universal Output_GND
5	+5V Reference_GND	5	Battery +
6	Universal Input_GND	6	Battery -
7	CAN_L	7	Encoder_B
8	CAN_H	8	Encoder_A
9	Universal Input 1	9	Magnetic Sensor Input 2
10	+5V Reference	10	Magnetic Sensor Input 1
11	Output 1, 1A	11	Output 2, 2A
12	Output 1, 2A	12	Output 2, 1A

Note: CANopen® is a registered community trademark of CAN in Automation e.V.

Form: TDAX100750-06/26/23