

Technical Datasheet#TDAX0905X0
12V or 24V BATTERY CHARGER/DC POWER SUPPLY

Battery Charger Mode
AC/DC Power Supply Mode
CAN bus (SAE J1939)
High Efficiency
with Axiomatic Electronic Assistant
P/N: AX090550, AX090560

Features:

- Charges a 12V or 24V lead-acid battery as well as other battery chemistries
- Maximum output power of 350 W (14V / 25A) in Model AX090550
- Maximum output power of 405W (27V / 15A) in Model AX090560
- Power supply mode: 95-260VAC/5-24Vdc, up to 15A
- Designed for mounting in a vehicle or in a stationary engine
- Managed heat dissipation so no fan cooling is required
- Wide ranging operation from 95 to 260 VAC, 45/65 Hz
- Highly efficiency design (90%)
- Inherent power factor correction
- Microprocessor controlled (standard control logic)
- Application-specific charging profiles for OEMs available
- Battery charging without operator involvement
- Configurable for battery optimization
- Monitors a remote battery temperature sensor for safe operation and prevention of battery overheating
- Transmits charger condition, line connection status, battery voltage, and charge current over CAN bus
- Four relays to connect to independent alarms for AC fail, charger fail, low battery volts, and high battery volts or for other uses
- Error mode shutdown
- Precharge, Bulk Charge, and Constant Voltage charge modes. Equalization is available as needed.
- Automatic retain charge in Float mode
- Permits load connection to battery (after fully charged) with Float Mode enabled
- Software overvoltage protection can be activated to ensure load safety if it cannot tolerate 31Vpeak output
- CAN (SAE J1939)
- LED Indicator
- The **Axiomatic Electronic Assistant** configures the charger to suit the application.
- Operational from -40 to 70°C (-40 to 158°F) for input >170VAC
- Corrosion resistant packaging, IP67 rated for harsh environments, vibration compliant
 - Add on module options: CAN to Ethernet Converter; CAN to Modbus RTU Converter; CAN to Bluetooth Converter



Applications:

- Off-highway Vehicles, Lift Equipment, Electric Vehicles, Fleet and Utility Vehicles, Emergency Vehicles
- Power Gensets, Oil and Gas Equipment, Electric Utility Substation Switchgear

Ordering Part Numbers:

<p>Battery Charger, 12V, 25A model: AX090550 Battery Charger, 12V/24V, 15A model: AX090560</p> <p>DC Power Supply, 12V/25A model: AX090550-04</p> <p>DC Power Supply, 12V/15A model: AX090560-04 DC Power Supply, 24V/15A model: AX090560-05 Contact Axiomatic for other requirements.</p> <p>Axiomatic Electronic Assistant Configuration KIT, P/Ns: AX070502, or AX070506K Mating Plug kits: Mating receptacle assemblies can be ordered from a Molex supplier.</p>
--

<p>COMMUNICATION OPTIONS:</p> <p>Optional CAN/Bluetooth Converter: AX141150 Optional CAN/CAN/Modbus RTU Converter: AX140100 Optional CAN/Ethernet Converter: AX140900 Optional 1 Analog Signal/CAN Controller: AX030530</p>

Technical Specifications:

Specifications are indicative and subject to change. Actual performance will vary depending on the application and operating conditions. Users should satisfy themselves that the product is suitable for use in the intended application. All our products carry a limited warranty against defects in material and workmanship. Please refer to our Warranty, Application Approvals/Limitations and Return Materials Process as described on <https://www.axiomatic.com/service/>.

Input Specifications

Power Supply Input - Nominal	120 VAC, 208VAC or 240VAC nominal 95 to 260 VAC, 45/65 Hz power supply range (60 Hz units and 50/60 Hz units) Power factor correction >0.99 @ 120VAC; >0.98 @ 240VAC Two internal fuses L and N, 8A, 250VAC
Surge Protection	Provided
Under-voltage Protection	Provided
Over-voltage Protection	Provided

Output Specifications

Output to Battery	Model AX090550: Maximum output is 350 Watts @ 14VDC, 25A Model AX090560: Maximum output is 405 Watts @ 27VDC, 15A
Protection Against Reverse Battery Connection	Provided
Over-voltage Protection	Provided
Battery Charger Mode: Output Voltage and Current (nominal depending on settings)	User configurable Model AX090550: Voltage: 10 – 15 VDC depending on the charging mode and user configuration. Current: 0.5 – 25 ADC depending on the charging mode and user configuration. Model AX090560: Voltage: 10 – 30 VDC depending on the charging mode and user configuration. Current: 0.5 – 15 ADC depending on the charging mode and user configuration.
AC/DC Power Supply Mode	User Configurable Output 5V-24Vdc up to 15A
Thermal Protection	A connection point is provided for an external NTC thermistor (not supplied) to protect the battery. The input is 5V via a 1K00 Ohm pull-up resistor inside the charger.
Relay Outputs	4 independent alarms for AC fail, charger fail, low battery volts, high battery volts to meet NFPA 110 requirements or for other functions Dry contacts (FORM C) Rating of relays: 2A max @ 30Vdc (resistive load), UL Class 2

General Specifications

Microcontroller	STM32F205VGT7, 32-bit, 1MByte flash memory
Control Logic	Standard embedded software Battery charger setpoints can be viewed and configured through the CAN bus using the Axiomatic Electronic Assistant (EA).
Recommended Battery Type	Model AX090550: Generic automotive 12V rechargeable lead acid batteries Model AX090560: Generic automotive 24V rechargeable lead acid batteries Other battery chemistries are available on request.
Recommended Battery Capacity	Up to 100 Ah
Efficiency	90% @ max. load and 240VAC 87% @ max. load and 120VAC
Diagnostics	The charger's dynamic parameters, voltage and current are broadcast over the J1939 network.
LED	LED Indicator Refer to User Manual Section 4.0 for details.
User Interface	Axiomatic Electronic Assistant KIT, P/Ns: AX070502, or AX070506K, for <i>Windows</i> operating systems. It comes with a royalty-free license for use on multiple computers.
CAN Interface	1 CAN port (ISO 11898 compatible) Termination resistor is not installed. SAE J1939 stack; Baud Rate: 250 bit/sec.
Optional Communication Interfaces	The following converters can be installed to interface with industrial fieldbus communications or wireless communications. CAN/Bluetooth Converter: AX141100 CAN/CAN/Modbus RTU Converter: AX140100 CAN/Ethernet Converter: AX140900
Fusing	Model AX090550: An external output fuse of 30 Amps is recommended. Model AX090560: An external output fuse of 20 Amps is recommended.
Operating Temperature (ambient)	-40 to 70°C (-40 to 158°F) for input >170VAC -40 to 60°C (-40 to 140°F) for input 90 to 170 VAC
Storage Temperature	-40 to 105°C (-40 to 221°F)
Protection Rating	OEM model: IP67
Approvals	PENDING CE marking, FCC, UL recognition
Vibration	PENDING MIL-STD-202G, Test 204D and 214A (Sine and Random) 10 g peak (Sine); 7.86 Grms peak (Random)
Shock	PENDING MIL-STD-202G, Test 213B; 50 g
Enclosure and Dimensions- Battery Charger	ACD12 Die Cast Aluminum Enclosure and Lid, Hard Anodized to MIL-A-8625 Type II Class I Clear Hard Anodize Molded EPDM Gasket Molex Connectors (See electrical connections.) 11.83 x 8.74 x 3.88 inches (300 x 222 x 98 mm) L x W x H excluding power cable assembly Refer to the dimensional drawing, Figure 1.0.
Weight	4.726 kg (10.420 lb.)
Power Connection	Power Cable: Heyco 3213 sealed cable gland Integral 3 ft. (0.91 m) unterminated power cable . The power plug is not supplied. Black Wire: Live White Wire: Neutral Green Wire: Ground

Electrical Connections	<p>1 4-pin Molex 194280006 (Mates with Molex 194180004 Receptacle) CAN Connector:</p> <table border="1" data-bbox="597 300 1015 430"> <thead> <tr> <th>PIN#</th> <th>Function</th> </tr> </thead> <tbody> <tr> <td>1</td> <td>CAN_H</td> </tr> <tr> <td>2</td> <td>CAN_L</td> </tr> <tr> <td>3</td> <td>Not Used</td> </tr> <tr> <td>4</td> <td>CAN_SH</td> </tr> </tbody> </table> <p>1 12-pin Molex 194280001 (Mates with Molex 194180027 Receptacle) Relay Outputs Connector:</p> <table border="1" data-bbox="597 527 1015 863"> <thead> <tr> <th>PIN#</th> <th>Function</th> </tr> </thead> <tbody> <tr> <td>1</td> <td>Relay 1 NO</td> </tr> <tr> <td>2</td> <td>Relay 1 COM</td> </tr> <tr> <td>3</td> <td>Relay 1 NC</td> </tr> <tr> <td>4</td> <td>Relay 2 NO</td> </tr> <tr> <td>5</td> <td>Relay 2 COM</td> </tr> <tr> <td>6</td> <td>Relay 2 NC</td> </tr> <tr> <td>7</td> <td>Relay 4 NO</td> </tr> <tr> <td>8</td> <td>Relay 4 COM</td> </tr> <tr> <td>9</td> <td>Relay 4 NC</td> </tr> <tr> <td>10</td> <td>Relay 3 NC</td> </tr> <tr> <td>11</td> <td>Relay 3 COM</td> </tr> <tr> <td>12</td> <td>Relay 3 NO</td> </tr> </tbody> </table> <p>1 6-pin Molex 1943506011 (Mates with Molex 194180010 Receptacle) Battery Connector:</p> <table border="1" data-bbox="597 959 1015 1142"> <thead> <tr> <th>PIN#</th> <th>Function</th> </tr> </thead> <tbody> <tr> <td>1</td> <td>Output to Battery +</td> </tr> <tr> <td>2</td> <td>Output to Battery -</td> </tr> <tr> <td>3</td> <td>Battery Temperature -</td> </tr> <tr> <td>4</td> <td>Output to Battery +</td> </tr> <tr> <td>5</td> <td>Output to Battery -</td> </tr> <tr> <td>6</td> <td>Battery Temperature +</td> </tr> </tbody> </table> <p>NOTE: When in AC/DC power supply mode, connect as follows. This product supports one battery output. The 2 pins for Batt+ and 2 pins for Batt- are used to share the current through them. For example, a 10A system will work with Pin 1 and Pin 2 connected but it is recommended to connect all 4 pins (Pins 1&4 joined together to Batt+ and Pins 2&5 to Batt-).</p>	PIN#	Function	1	CAN_H	2	CAN_L	3	Not Used	4	CAN_SH	PIN#	Function	1	Relay 1 NO	2	Relay 1 COM	3	Relay 1 NC	4	Relay 2 NO	5	Relay 2 COM	6	Relay 2 NC	7	Relay 4 NO	8	Relay 4 COM	9	Relay 4 NC	10	Relay 3 NC	11	Relay 3 COM	12	Relay 3 NO	PIN#	Function	1	Output to Battery +	2	Output to Battery -	3	Battery Temperature -	4	Output to Battery +	5	Output to Battery -	6	Battery Temperature +
PIN#	Function																																																		
1	CAN_H																																																		
2	CAN_L																																																		
3	Not Used																																																		
4	CAN_SH																																																		
PIN#	Function																																																		
1	Relay 1 NO																																																		
2	Relay 1 COM																																																		
3	Relay 1 NC																																																		
4	Relay 2 NO																																																		
5	Relay 2 COM																																																		
6	Relay 2 NC																																																		
7	Relay 4 NO																																																		
8	Relay 4 COM																																																		
9	Relay 4 NC																																																		
10	Relay 3 NC																																																		
11	Relay 3 COM																																																		
12	Relay 3 NO																																																		
PIN#	Function																																																		
1	Output to Battery +																																																		
2	Output to Battery -																																																		
3	Battery Temperature -																																																		
4	Output to Battery +																																																		
5	Output to Battery -																																																		
6	Battery Temperature +																																																		
Mating Connectors:	Mating receptacle assemblies can be ordered from a Molex supplier.																																																		
Mounting	Use 6 M8 or #4 bolts to mount the device.																																																		

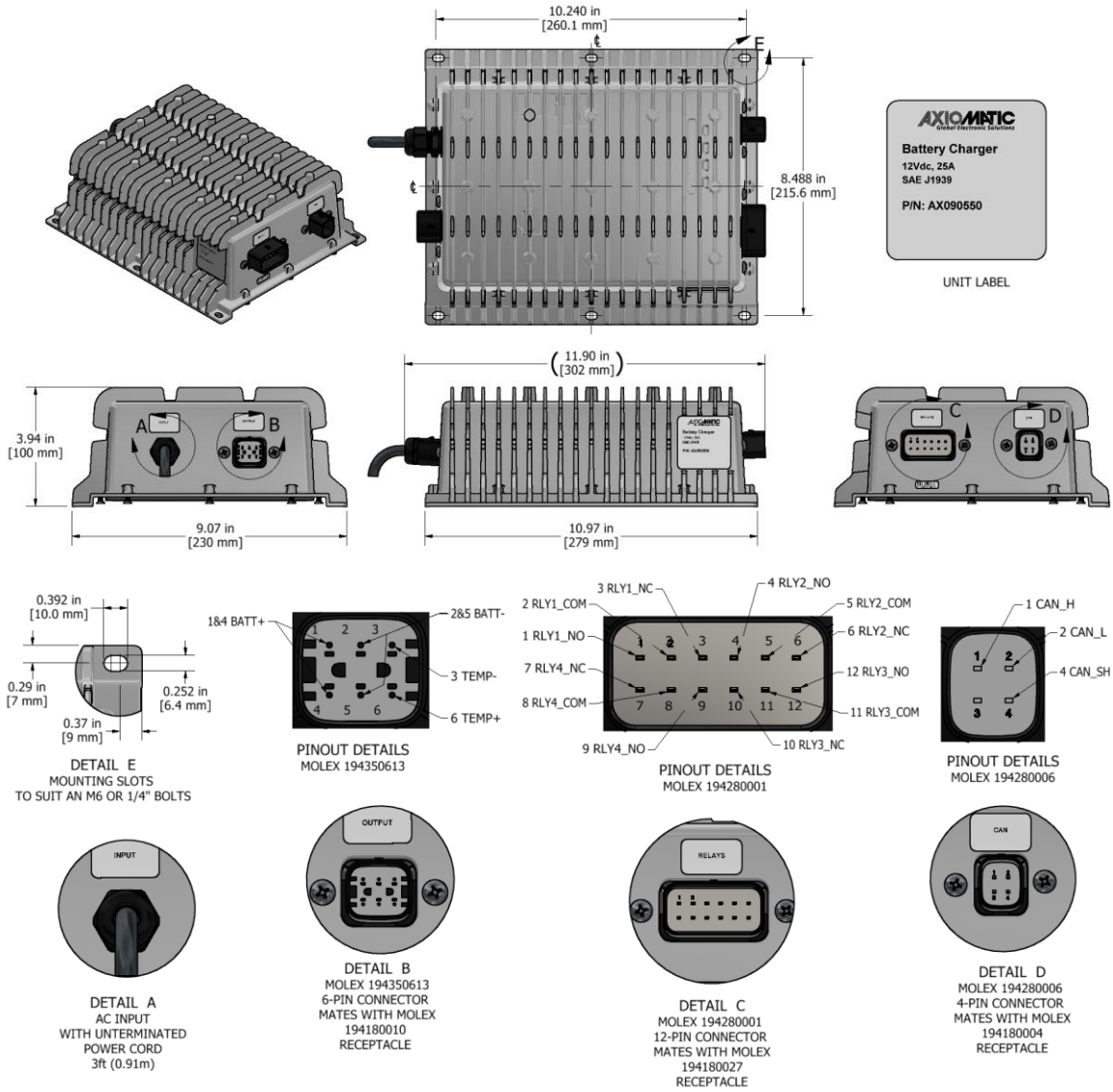

Fig. 1 Dimensional Drawing – AX090550

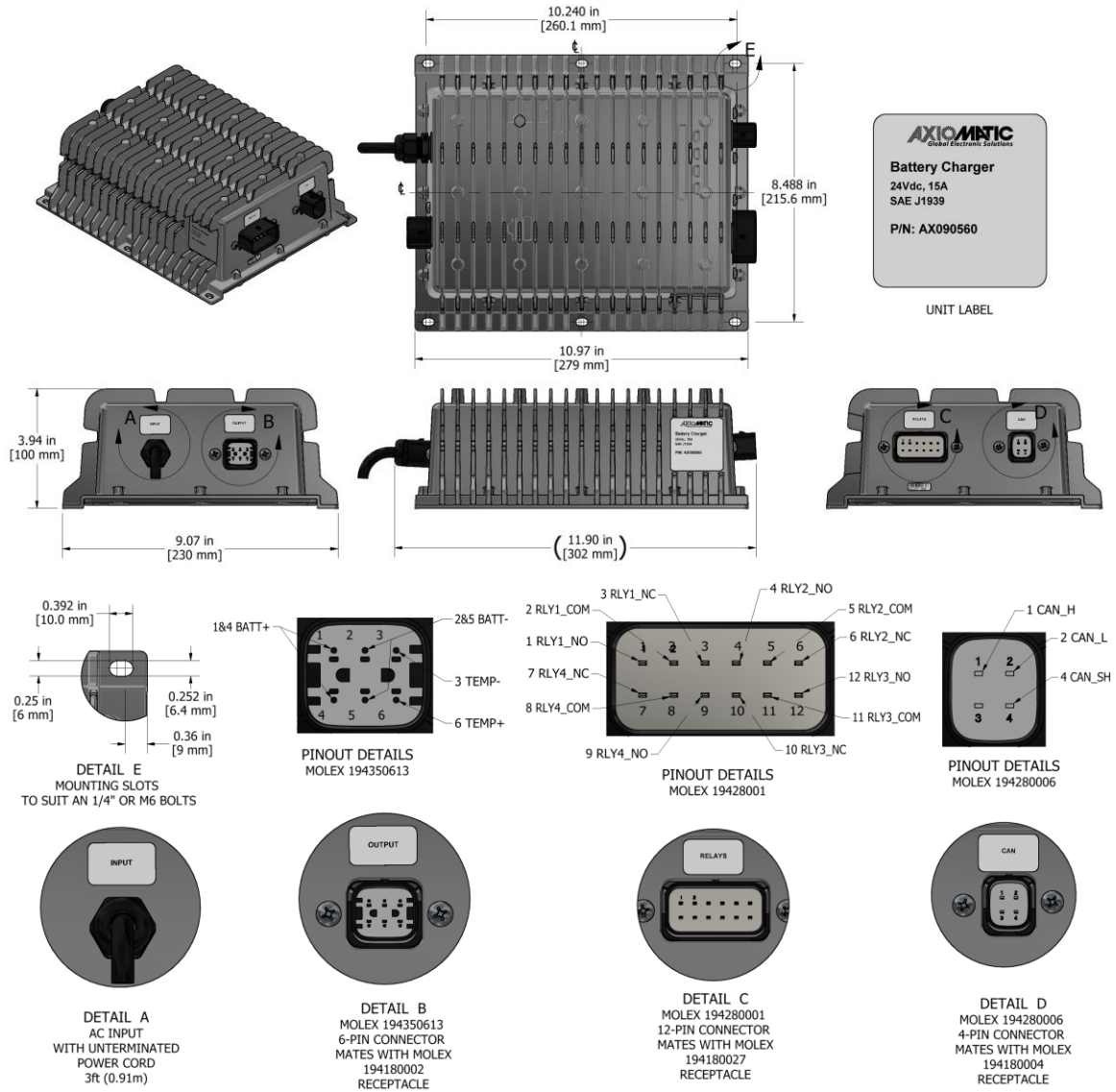

Fig. 2 Dimensional Drawing – AX090560

Battery Charger Algorithm:

The Battery Charger implements a three-stage charging algorithm, as shown below in Figure 2.

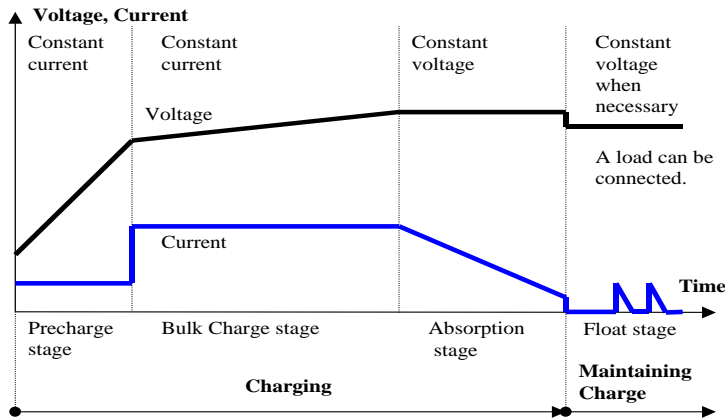

Fig. 2 Three-stage charging algorithm profile with a separate maintaining charge stage

The charging process starts from Precharge Stage, then, when the battery voltage reaches a certain point, it switches to the Bulk Charge Stage. Next, the charging process is finalized in the Absorption (Constant Voltage) Stage. The charger can then maintain the battery charge in Float Stage.

When the charger is disconnected from the power line, it automatically switches off within one minute by default. This protects the battery from being discharged by the charger electronics.

Charge Modes:

Each stage of the charging process has its own one or two charger modes. There are also modes reflecting an idle or an error condition of the charger.

Idle Mode

In Idle Mode the charger internal output is disconnected from the battery.

Idle Mode is an initial mode in the battery charging process. After power-up the charger starts operating from this mode. The charger will also switch to Idle mode if the battery is disconnected, ensuring that a battery will be properly charged even in case of hot-swap replacing of the batteries in the middle of the charging process.

Precharge Mode

In Precharge Mode, a relatively small constant current, I_{pc} , charges the battery, see Figure 3.

Precharge Mode is used at the beginning of the charge process for deeply discharged batteries. The precharge current, I_{pc} , is set lower than the regular bulk charge current, I_{bc} , in order to prevent gassing damage of the batteries. When the battery voltage reaches V_{bc_start} , the charger switches to Bulk Charge Mode and the charging current increases.

Bulk Charge Mode

In Bulk Charge Mode, a high constant current, I_{bc} , charges the batteries.

Bulk Charge Mode is the main charging mode of the battery charger. During this mode the battery is charged approximately to 80% of its maximum charge. While charging, the battery voltage increases, and when it reaches V_{cv_start} , the charger switches to Constant Voltage Mode to complete the charging process.

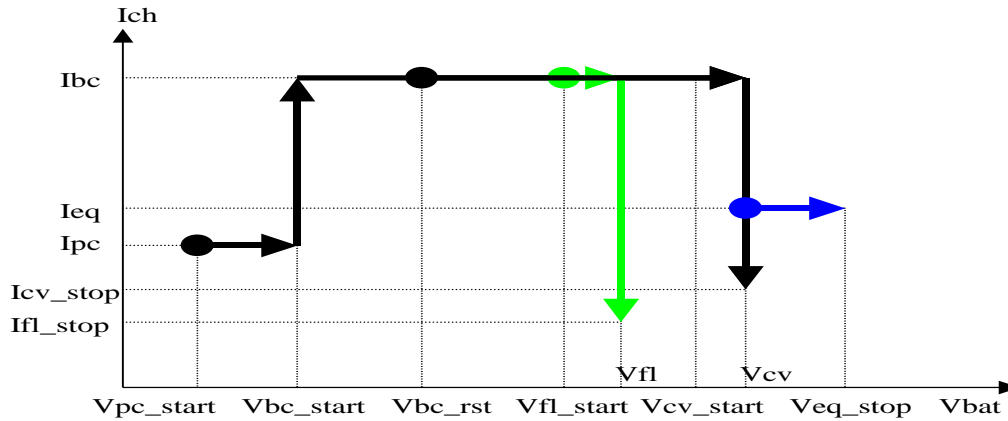

Fig.3. Voltage-Current Charging Profile

Constant Voltage Mode

In Constant Voltage Mode the output voltage of the charger is limited to V_{cv} and the output current – to I_{bc} . Once the battery voltage reaches V_{cv} , the charger is not able to maintain the I_{bc} constant charging current, so the current gradually drops to I_{cv_stop} and the battery is considered fully charged.

Constant Voltage Mode is usually the last charging mode in the charging process. At the end of this mode the charger switches to either Standby or Equalize Mode.

Equalize Mode

In Equalize Mode a constant I_{eq} current charges the battery until the battery voltage reaches V_{eq_stop} or the equalization time, T_{eq} , has expired.

Only flooded lead-acid (FLA) batteries require equalization. This procedure is activated manually, from time to time according to the battery specification by setting the ActivateEqualizeMode setpoint through the menu. The setpoint value will be automatically reset after the charger enters the Equalize Mode preventing the charger from running the equalization process more than one time.

Float Mode

Float Mode is required to maintain the batteries at full charge. The mode can be enabled by setting FloatMode=Enable setpoint through the menu. When Equalize Mode is set, the Float Mode is temporarily disabled until the reset of the ActivateEqualizeMode setpoint.

When the mode is enabled, the battery charger switches to Float Mode when the battery voltage drops below V_{fl_start} . As in the Constant Voltage Mode, while in Float Mode the battery charger limits the output voltage to V_{fl} and the output current to I_{bc} .

Standby Mode

In Standby Mode the battery is fully charged and the charger output is disconnected from the battery.

The charger will automatically switch to Float or Bulk Charge Mode if the battery voltage drops below V_{fl_start} or $V_{bc_restart}$, respectively.

Battery Error Mode

Battery Error Mode serves as a terminal point where the charging process stops in case of a battery error condition.

Module Error Mode

Module Error Mode stops the charging process and is activated in case of a charger internal error during charging.

The only way to exit Battery Error or Module Error Modes is to cycle the power or reconnect the battery. In this case, the battery charger will go to Idle Mode.

Refer to the Figure 4 for more details.

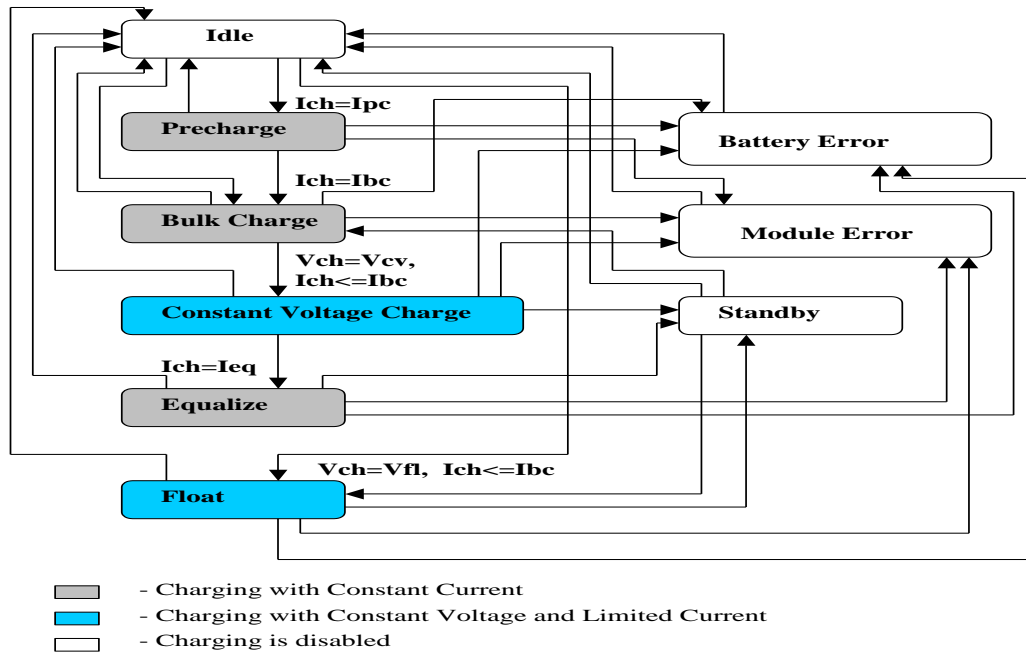

Fig. 4 Battery charger state diagram

Form: TDAX0905X0-07/27/23