

RUGGED
TILT SENSOR

with 2 Outputs up to 2A

CANopen®

P/N: AX060150

Application:

Rugged out-of-level indicator and shut down control for mobile equipment including:
manlifts, aerial lifts, forklifts, cranes,
emergency vehicles, and agricultural equipment.

Features:

- Indicates out of level condition from mounting location and drives external valves, solenoids, relays, lamps or annunciators for equipment shut down control or warning system
- Two operation modes
 - > Mode 1: 360°
 - > Mode 2: XY (single axis or two axes)
- Up to 4 trip angles available per axes (minimum of 2 trip angles for operation)
- AND Logic (both axis must be within range to activate or de-activate output) as well as OR logic (either one axis can activate or de-activate output) available
- Superior performance with an accuracy of up to 0.1° over a wide range of temperatures
- Internal compensation for temperature drift, +/- 0.1° error over operating range
- Solid state silicon chip sensor for quick response time in high vibration environments
- Drives up to two on/off valves, proportional valves, relays or other devices (up to 2 Amps)
- Failsafe ensures unit turns off when trip angle exceeded (reverse logic available)
- LED's indicate unit is powered and axis is out of level
- Factory settings to meet customer specification
- Degree of trip angle(s) specified by user within 0.5 to 90°
- Hysteresis is user specified
- Boot up time delay is user specified from 0.01 to 5 seconds
- Filter time delay is user specified from 0.01 to 5.0 seconds
- User configurable over CANopen® (or application-specific defaults on request)
- User zeros sensor over CAN
- Accepts 9 to 32 VDC (12 or 24V battery typical)
- Reverse polarity protection provided
- Encapsulated in a stainless steel box for the rugged mobile environment
- Compact, remote mount, IP67 rated packaging and watertight 6-pin connection
- Operational from -40 to 85°C



Ordering Part Numbers:

Tilt Sensor: **AX060150**

Mating Wire Harness Assembly, 2 meters: **AX070300**

All wire harnesses will come with unterminated lead wires unless otherwise requested.

To configure the unit, use a commercially available CAN to USB service tool.

For factory-set defaults to suit the application, please specify upon ordering:

- Operation mode: 360° (x axis) or XY (x and y axes)
- Number of trip angles (sectors)
- Degree of trip angles for x and y axes (if necessary)
- Hysteresis
- Boot up delay time
- Filter delay time
- Type of output required (on/off in Amps or PWM – option)
- Normally ON - Operating Mode or Failsafe (Unit turns off when trip angle is exceeded.)
- Normally OFF (A reverse operating mode model is available.)

BLOCK DIAGRAM

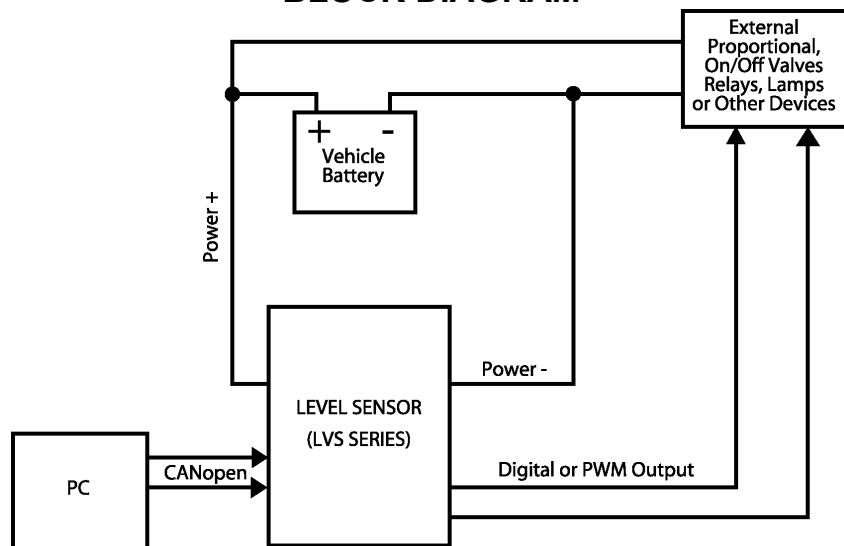

Technical Specifications:

All specifications are typical at nominal input voltage and 25°C unless otherwise specified.

Specifications are indicative and subject to change. Actual performance will vary depending on the application and operating conditions. Users should satisfy themselves that the product is suitable for use in the intended application. All our products carry a limited warranty against defects in material and workmanship. Please refer to our Warranty, Application Approvals/Limitations and Return Materials Process as described on <https://www.axiomatic.com/service/>.

Electrical Specifications

| | |
|---|---|
| Operating voltage (power supply requirement) | 9 to 32 VDC power supply range Transient surge protection provided |
| Supply current | 51 mA @ 12V 39 mA @ 24V |
| Reverse polarity protection | Provided |
| Degree of trip angle – X axis | Specify angle between 0.5 to 90° Default (+5°, -5°) Accuracy +/- 0.5° |
| Degree of trip angle – Y axis | Specify angle between 0.5 to 90° Default (+5°, -5°) Accuracy +/- 0.5° |
| Hysteresis | Please specify upon ordering (0.1° minimum). Default (1° minimum) |
| Boot Up Time Delay | Specify time between 0.01 to 5.0 seconds. (System boot up or upon reset delay.) |
| Filter Time Delay | Specify time between 0.01 to 5.0 seconds. Default (0.5 seconds) <i>Time delays > 1 second are not recommended.</i> (Time duration angle must be maintained before controller activates output.) |
| Output | Sourcing Digital on/off output – up to 2 Amps User selectable: Proportional Current or PWM up to 2A (on request) Short circuit protected. |
| Type | Normally Open (Normally Closed unit is available on request.) Normally ON - Operating Mode (Failsafe) – Unit turns off when trip angle exceeded. A reverse model (Normally OFF) is available where the unit remains off until trip angle is exceeded and then it turns on. Default (Normally OFF – unit turns ON outputs when trip angles are exceeded.) |
| Modes | Mode 1: 360 (2 to 4 trip points) Output A and B controlled by x-Axis can be active. Mode 2: XY (2 to 4 trip points per axis) Output A and B can be active. Default (XY mode) |
| Options - programmable | Dual trip point (Hi trip point and reset trip in single axis model) Normally Closed |

General Specifications

| | |
|---------------------------|--|
| Microprocessor and Sensor | STM32F405RG Microprocessor SCA3300 Sensor |
| Control Logic | Standard embedded control logic is provided. |
| Operating conditions | -40 to +85°C (-40 to 185°F) |
| Accuracy | Trip point is repeatable to within 0.1 degrees over operating temperature range |
| Communications | CANopen® PC-based configuration is provided by using CANopen® object viewer software. |
| LED indicators | Green LED ON = Power OK Red LED1 ON = Output A ON |

| | |
|--------------------------|--|
| | Red LED2 ON = Output B ON |
| Electrical connection | 6-pin connector (equivalent TE Deutsch P/N: DT15-6P) Mates with an equivalent to the TE Deutsch P/N: DT06-6S, including W6S wedgelock and sockets. (available as a plug kit or wire harness on request). Use dielectric grease on the pins when installing the unit. |
| Pin out | Pin 1 – Power GND Pin 6 – Power + Pin 2 – Output_A Pin 3 – Output_B Pin 4 – CAN Lo Pin 5 – CAN Hi To ground the 2 outputs' loads, tie their return wires to Power GND. |
| Protection class | IP67 |
| Weight | 0.71 lbs. (0.32 kg) |
| Enclosure and dimensions | Encapsulated in stainless steel box 108.22 x 42.04x 62.64 mm 4.26 x 1.655 x 2.46 inches (W x H x D) |

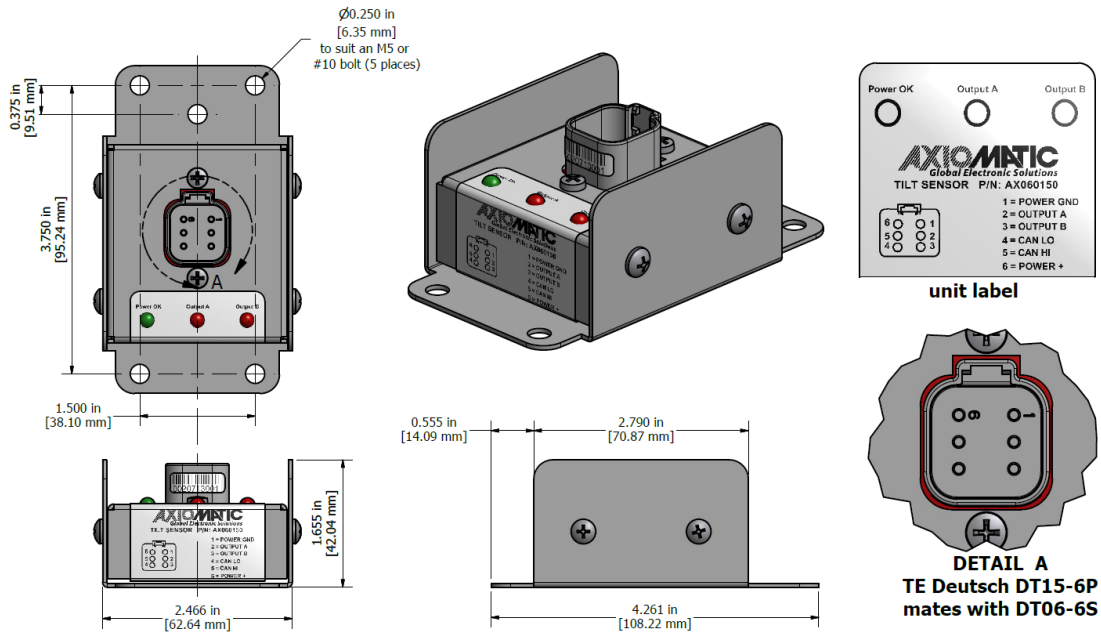

CANopen® is a registered community trademark of CAN in Automation e.V.

Form: TDAX060150-07/04/23