

**Technical Datasheet #TDAX031851**  
**Discrete I/O**  
**P/N: AX031851**  
**12 inputs, 8 relay outputs, CANopen®**

**Description:** The Discrete I/O Module reads 12 discrete inputs and sets 8 Form C relay outputs while networking with other CAN devices (SAE J1939) in a machine control system. The unit is a battery powered device with the ability to withstand engine cranking, reverse polarity and transient power conditions. Outputs can be controlled by any input or CAN message. The AX031851 has a number of setpoints that allow the user to configure it for their application. The AX031851 features a rugged enclosure, gasketing and watertight connectors for an IP67 rating.



**Applications:** Power Generator Sets, Diesel Engine Control Systems

- Modules are designed for mounting on power generator sets or remotely up to 30 ft.
- Multiple AX031851 modules can be used on a CAN network.

**Ordering Part Numbers:**

CANopen® Discrete I/O Controller: <b>AX031851</b> SAE J1939 Discrete I/O Controller, 250 kbps: <b>AX031850</b> (Refer to TDAX031850.)
------------------------------------------------------------------------------------------------------------------------------------------

EDS File: Download from <a href="http://www.axiomatic.com">www.axiomatic.com</a> .
------------------------------------------------------------------------------------

Mating Plug Kit P/N: <b>AX070147</b>
--------------------------------------

## Technical Specifications

Specifications are indicative and subject to change. Actual performance will vary depending on the application and operating conditions. Users should satisfy themselves that the product is suitable for use in the intended application. All our products carry a limited warranty against defects in material and workmanship. Please refer to our Warranty, Application Approvals/Limitations and Return Materials Process as described on <https://www.axiomatic.com/service/>.

### Inputs

Power Supply Input	12V or 24VDC nominal (9...32 VDC power supply range)
Supply Current	170 mA @ 12Vdc Typical 85 mA @ 24Vdc Typical
Protection	Reverse polarity protection is provided. Power supply input section protects against transient surges and short circuits.
Inputs	Reads twelve (12) discrete inputs (active low with pull-up resistors) Input level characteristics: Low-Level input voltage: 0 to 0.8 V High-Level input voltage: 3.75 to +BAT Inputs have internal pull-up resistors. Input resistance: more than 5 kOhms The inputs have internal over and under voltage protection.
Digital GNDs	The digital inputs should be grounded to the Power Ground.

### Outputs

Outputs	Sets 8 Form C relay outputs. Resistive load: <ul style="list-style-type: none"> <li>5A (NO)/5 A (NC) at 30 VDC</li> </ul> Dielectric strength: <ul style="list-style-type: none"> <li>4,000 VAC, 50/60 Hz for 1 min between coil and contacts</li> <li>750 VAC, 50/60 Hz for 1 min between contacts of same polarity</li> </ul> There is no special overcurrent/overvoltage protection on the relay outputs. The user is advised to provide a fast acting 6A fuse or an adequate external protection if necessary.
---------	-----------------------------------------------------------------------------------------------------------------------------------------------------------------------------------------------------------------------------------------------------------------------------------------------------------------------------------------------------------------------------------------------------------------------------------------------------------------------------------------------------------------------------

### Communication

CAN	1 CAN 2.0B port, protocol CANopen® (SAE J1939 model is P/N: AX031850.) Digital isolation is provided for the CAN line.
-----	------------------------------------------------------------------------------------------------------------------------------

### General Specifications

Microcontroller	STM32F405RG
Network Termination	According to the CAN standard, it is necessary to terminate the network with external termination resistors. The resistors are 120 Ohm, 0.25W minimum, metal film or similar type. They should be placed between CAN_H and CAN_L terminals at both ends of the network.
User Interface	EDS File Use standard CANopen® tools (not supplied)
Operating Temperature Range	-40 to 85 °C (-40 to 185 °F)
Storage Temperature Range	-50 to 120 °C (-58 to 248 °F)
Humidity	Protected against 95% humidity non-condensing, 30 °C to 60 °C
Protection	IP67, IP69K
Weight	0.45 lb. (0.204 kg)
UL and cUL Compliance	Standard for Controllers for Use in Power Production, CAN/ULC 6200, 1 <sup>st</sup> edition
CE/UKCA Compliance	2004/108/EC (EMC Directive) 2011/65/EU (RoHS Directive)
Marine Type Approval	Pending
Vibration	MIL-STD-202G, Test 204D and 214A (Sine and Random) 10 g peak (Sine); 7.86 Grms peak (Random)
Shock	MIL-STD-202G, Test 213B, 50 g
Control Logic	The AX031851 is designed to work either as a stand-alone module, or on a CANopen® network. For a more detailed description of the configurable sources, refer to the user manual.

Enclosure	CINCH mini-ME enclosure P/N: 5810130090 Polyphthalamide (PPS) plastic resin, UR, Flammability Rating HB  CINCH 40-pin receptacle P/N: 5810140011 95 x 130 x 42 mm (3.73 x 5.13 x 1.67") L x W x H
Mating Plug Kit	AX070147 Comprised of: 1 Molex 33472-2001 (Key A) 1 Molex 33472-2002 (Key B) 40 Molex 33012-2002 Receptacle Terminals (for crimping) for 18AWG wire 6 Molex 34345-0001 Cavity Plugs  To crimp wires onto the receptacle terminals, please use the recommended crimping tools from Molex.
Electrical Pin Out – Power and CAN	Refer to Dimensional Drawing, Figure 1.0.

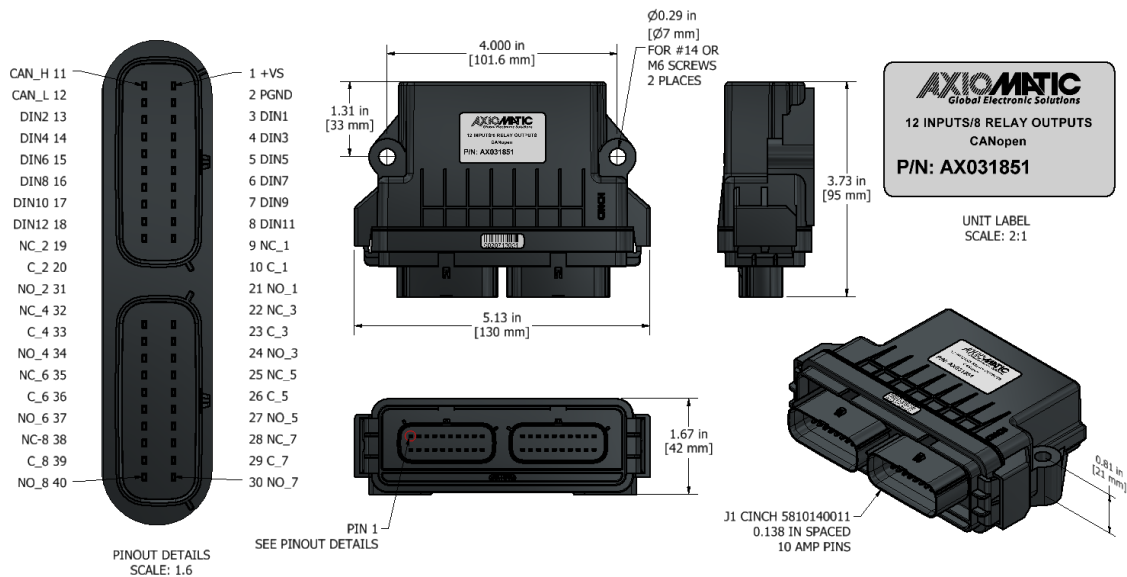

Figure 1.0 – Dimensional Drawing and Pin Out

CANopen® is a registered community trademark of CAN in Automation e.V.

TDAX031851-06/01/23