

Technical Datasheet #TDAX031850
Discrete I/O
P/N: AX031850
12 inputs, 8 relay outputs, SAE J1939
with Axiomatic Electronic Assistant

Description: The Discrete I/O Module reads 12 discrete inputs and sets 8 Form C relay outputs while networking with other CAN devices (SAE J1939) in a machine control system. The unit is a battery powered device with the ability to withstand engine cranking, reverse polarity and transient power conditions. In engine applications, information is provided to the engine control system using single-frame J1939 application-specific PDU2 type messages. Outputs can be controlled by any input or CAN message.

The AX031850 has a number of setpoints that allow the user to configure it for their application. The Windows-based Axiomatic Electronic Assistant can be used to configure the module over the CAN line. The setpoints can also be saved to a file and flashed into other AX031850 modules over the CAN bus. Settings are saved to non-volatile memory upon command.

The AX031850 features a rugged enclosure, gasketing and watertight connectors for an IP67 rating.



Applications:

- Power Generator Sets, Diesel Engine Control Systems
- Modules are designed for mounting on power generator sets or remotely up to 30 ft.
- Multiple AX031850 modules can be used on a CAN network.

Ordering Part Numbers:

| |
|---|
| SAE J1939 Discrete I/O Controller, 250 kbps: AX031850 |
| SAE J1939 Discrete I/O Controller, 500 kbps: AX031850-01 |
| SAE J1939 Discrete I/O Controller, 1 Mbps: AX031850-02 |
| CANopen® Discrete I/O Controller: AX031851 |

| |
|---|
| Axiomatic Electronic Assistant P/N: AX070502 , or AX070506K |
|---|

| |
|--------------------------------------|
| Mating Plug Kit P/N: AX070147 |
|--------------------------------------|

Technical Specifications

Specifications are indicative and subject to change. Actual performance will vary depending on the application and operating conditions. Users should satisfy themselves that the product is suitable for use in the intended application. All our products carry a limited warranty against defects in material and workmanship. Please refer to our Warranty, Application Approvals/Limitations and Return Materials Process as described on <https://www.axiomatic.com/service/>.

Inputs

| | |
|--------------------|---|
| Power Supply Input | 12V or 24VDC nominal (9...32 VDC power supply range) |
| Supply Current | 170 mA @ 12Vdc Typical 85 mA @ 24Vdc Typical |
| Protection | Reverse polarity protection is provided. Power supply input section protects against transient surges and short circuits. |
| Inputs | Reads twelve (12) discrete inputs (active low with pull-up resistors) Input level characteristics: Low-Level input voltage: 0 to 0.8 V High-Level input voltage: 3.75 to +BAT Inputs have internal pull-up resistors. Input resistance: more than 5 kOhms The inputs have internal over and under voltage protection. |
| Digital GNDs | The digital inputs should be grounded to the Power Ground. |
| PGNs | AX031850 is an Arbitrary Address Capable ECU. It can dynamically change its network address in real time. The AX031800 supports: Address Claimed Messages (PGN 60928); Requests for Address Claimed Messages (PGN 59904); and Commanded Address Messages (PGN 65240). AX031850 supports Transport Protocol for Commanded Address messages (PGN 65240). It also supports responses on PGN Requests (PGN 59904). It transmits Software ID PGN65242 (-SOFT) only on request. AX031850 can constantly transmit the state of digital inputs in a user defined PDU2 or PDU1 PGN, set to proprietary B PGN 65440 by default. AX031850 can receive user defined PDU2 or PDU1 PGN controlling any configurable source, set to 65448 by default. AX031850 can receive mode select commands or send mode status feedback in a user defined PDU2 or PDU1 PGN and is set to proprietary B PGN 65456 by default. |

Outputs

| | |
|---------|---|
| Outputs | Sets 8 Form C relay outputs. Resistive load: <ul style="list-style-type: none"> 5A (NO)/5 A (NC) at 30 VDC Dielectric strength: <ul style="list-style-type: none"> 4,000 VAC, 50/60 Hz for 1 min between coil and contacts 750 VAC, 50/60 Hz for 1 min between contacts of same polarity There is no special overcurrent/overvoltage protection on the relay outputs. The user is advised to provide a fast acting 6A fuse or an adequate external protection if necessary. |
|---------|---|

Communication

| | |
|-----|---|
| CAN | 1 CAN 2.0B port, protocol SAE J1939 (CANopen® is model AX031851.) Model AX031850 Baud Rate: 250 bit/sec. Model AX031850-01 Baud Rate: 500 kbit/sec. Model AX031850-02 Baud Rate: 1 Mbit/sec. Digital isolation is provided for the CAN line. Other features of the CAN communications interface include: <ul style="list-style-type: none"> In the case of a higher Baud Rate than 250 bit/sec, the slew rate will be automatically set to "high". Node address is auto configurable as per J1939-81 or per customer request. A watchdog timer to require a reboot when the microprocessor locks. The AX031850 is designed to remain powered during engine cranking. |
|-----|---|

General Specifications

| | |
|-----------------------------|---|
| Microcontroller | STM32F405RG |
| SAE J1939 Profile | <p>For J1939 compliance (SAE, Recommended Practice for a Serial Control and Communications Vehicle Network, October 2007) all modules comply with the applicable portions of the following:</p> <ul style="list-style-type: none"> • SAE J1939-21, Dec 2006, Data Link Layer • SAE J1939-71, Sep 2013, Application Layer • SAE J1939-73, Feb 2010, Application Layer – Diagnostic • SAE J1939-81, March 2017, Network Management <p><i>Customer specific proprietary extensions can also be included in the SAE J1939 profile on request.</i></p> |
| Network Termination | <p>According to the CAN standard, it is necessary to terminate the network with external termination resistors. The resistors are 120 Ohm, 0.25W minimum, metal film or similar type. They should be placed between CAN_H and CAN_L terminals at both ends of the network.</p> |
| User Interface | <p>For SAE J1939: controllers only Axiomatic Electronic Assistant KIT, P/Ns: AX070502, or AX070506K Updates for the Axiomatic EA are found on www.axiomatic.com under the log-in tab.</p> |
| Operating Temperature Range | -40 to 85 °C (-40 to 185 °F) |
| Storage Temperature Range | -50 to 120 °C (-58 to 248 °F) |
| Humidity | Protected against 95% humidity non-condensing, 30 °C to 60 °C |
| Protection | IP67, IP69K |
| CE/UKCA Compliance | 2004/108/EC (EMC Directive) 2011/65/EU (RoHS Directive) |
| Vibration | MIL-STD-202G, Test 204D and 214A (Sine and Random) 10 g peak (Sine); 7.86 Grms peak (Random) |
| Shock | MIL-STD-202G, Test 213B, 50 g |
| Weight | 0.45 lb. (0.204 kg) |
| Control Logic | <p>The AX031850 is designed to work either as a stand-alone module, or on J1939 CAN network. When connected to the network, it automatically recognizes network connection, claims a network address and can be configured to perform the following application tasks.</p> <ul style="list-style-type: none"> • Converts between physical I/O and CAN (SAE J1939) single frame commands • Converts between physical I/O and CAN (SAE J1939) single frame commands • Continuously broadcast any configurable sources using a proprietary Input-PGN • Receive and process Output-PGNs to control DIO sources <p>The AX031850 has nine different Sources (No Source, Digital Input, Relay Output, CAN Receive Message, CAN Transmit Message, Diagnostic Trouble Code, CAN Status Reports, Global VPS, Global Temperature), which are able to communicate to each other. Depending on the Output Source (Relay Output, CAN Transmit), a specific number of sources can be selected.</p> <ul style="list-style-type: none"> • The Relay Outputs have six different configurations to interchange information with their control sources. These configurations are Normal Logic, Inverse Logic, Latched Logic (changes state every time the control input transitions from OFF to ON), Inverse Latched Logic, and Toggle Logic (The output toggles in an adjustable time). • The Digital Input states are configurable to Normal Logic, Inverse Logic, and Latched Logic. • It is possible to set eight status bits into one byte by using a CAN Status Report source. These sources allow the CAN Transmit messages to send all Input and Output sates. <p>For a more detailed description of the configurable sources, refer to the user manual.</p> <p>AX031850 uses Memory Access Protocol (MAP) for setpoint programming from the Axiomatic Electronic Assistant.</p> |

| | |
|------------------------------------|---|
| Enclosure and Receptacle | <p>CINCH mini-ME enclosure P/N: 5810130090 Polyphthalamide (PPS) plastic resin, UR, Flammability Rating HB</p> <p>Conformal coated PCB assemblies</p> <p>CINCH 40-pin receptacle P/N: 5810140011 95 x 130 x 42 mm (3.73 x 5.13 x 1.67") L x W x H</p> |
| Mating Plug Kit | <p>AX070147 Comprised of: 1 Molex 33472-2001 (Key A) 1 Molex 33472-2002 (Key B) 40 Molex 33012-2002 Receptacle Terminals (for crimping) for 18AWG wire 6 Molex 34345-0001 Cavity Plugs</p> <p>To crimp wires onto the receptacle terminals, please use the recommended crimping tools from Molex.</p> |
| Electrical Pin Out – Power and CAN | Refer to Dimensional Drawing, Figure 1.0. |

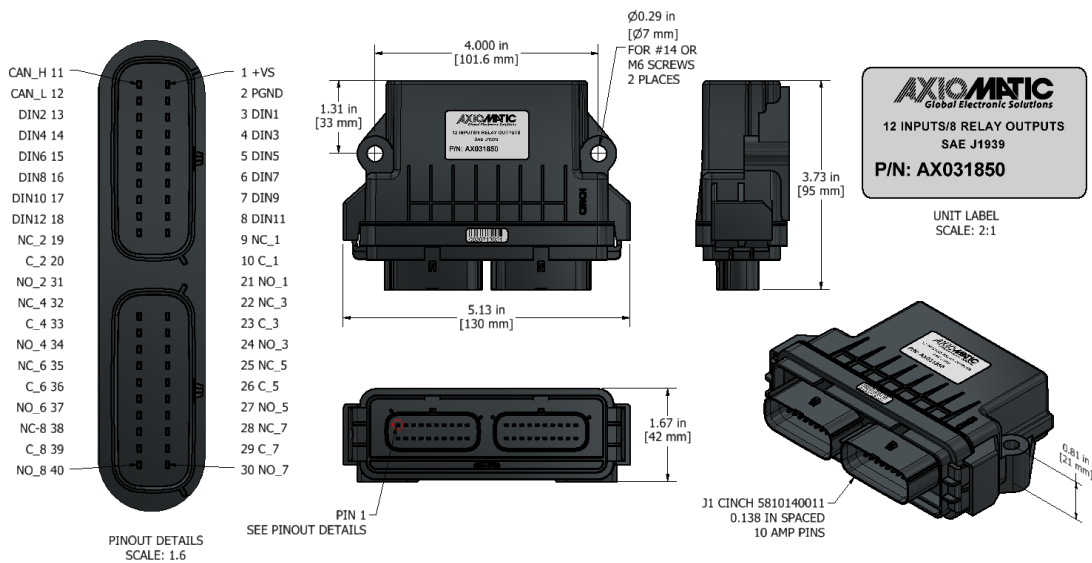

Figure 1.0 – Dimensional Drawing and Pin Out

CANopen® is a registered community trademark of CAN in Automation e.V.

TDAX031850-07/12/23