

1 Analog Signal Output CAN Controller (SAE J1939)

*Distributed I/O for Engine Control Systems
with Axiomatic Electronic Assistant*

P/N: AX030520

Features

- 1 analog signal output (voltage or current)
- User selectable output range from +/-10V or +/-20 mA, including: 0-5V; 0-10V; +/-5V; +/-10V; 0-20mA; and 4-20 mA.
- Embedded output voltage and current monitoring
- 12V/24V/48VDC input power (nominal) with rugged surge protection
- 1 CAN (SAE J1939)
- A CANopen® model is available as P/N: AX030521.
- Rugged enclosure and connectors
- CE / UKCA marking
- Axiomatic Electronic Assistant for user configuration and programming



Applications

- Distributed controls for power generation, co-generation, stationary power
- Distributed controls for commercial vehicles, off-highway equipment, industrial equipment, etc.

Ordering Part Numbers

1 Analog Signal Output CAN Controller (SAE J1939), P/N: **AX030520**

Accessories:

Mating Plug KIT, P/N: **AX070112**

Axiomatic Electronic Assistant Configuration KIT, P/Ns: **AX070502** or **AX070506K**

Block Diagram

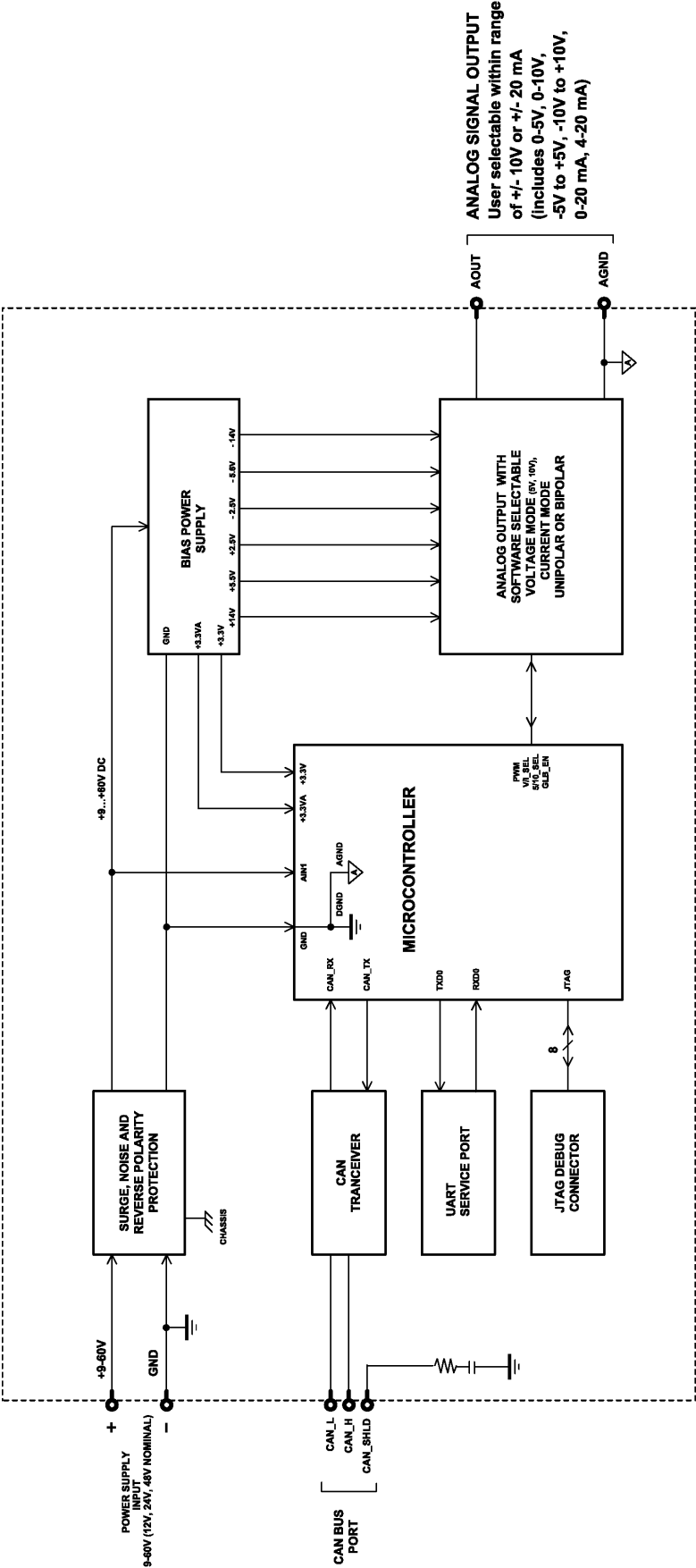

Technical Specifications

Specifications are indicative and subject to change. Actual performance will vary depending on the application and operating conditions. Users should satisfy themselves that the product is suitable for use in the intended application. All our products carry a limited warranty against defects in material and workmanship. Please refer to our Warranty, Application Approvals/Limitations and Return Materials Process as described on <https://www.axiomatic.com/service/>.

Input

Power Supply Input - Nominal	12V, 24V or 48VDC nominal (9...60 VDC power supply range)
Protection	Surge and reverse polarity protection are provided.
Input	<p>CAN Messages, SAE J1939 A CANopen® model is available. (P/N: AX030521)</p> <p>The CAN signal can be filtered to accept messages from a single address on the network permitting a link to a specific ECU.</p> <p>There are three CAN Input Signal functional blocks supported by the controller. Each functional block can be programmed to read single-frame CAN messages and extract CAN signal data presented in virtually any user-defined signal data format. The functional block then outputs the signal data to its logical output for processing by other functional blocks of the controller. (Refer to Figure 1.0.)</p> <p>By default, the output of the first CAN Input Signal functional block is connected to the input of the Analog Signal Output functional block. It provides the simplest controller configuration with a direct control of the signal output by the CAN input signal. The second and third CAN Input Signal functional blocks, not connected by default, can be engaged in more complicated CAN signal acquisition and processing algorithms involving Binary Function functional blocks and other controller resources.</p> <p>The Axiomatic Electronic Assistant (EA) is used to set up CAN signal acquisition and processing algorithms.</p>

Output

CAN	The controller can send a single frame application specific CAN message to the network continuously or on request. Using the EA, the user can configure this feature.
Analog Outputs	1 analog signal output Refer to Table 1.0.
Ground Connection	1 Analog GND connection is provided.
Protection for Output + Terminal	Fully protected against short circuit to ground and short circuit to power supply rail. Unit will fail safe in the case of a short circuit condition, self-recovering when the short is removed.

Table 1.0 - Outputs	
Analog Output	<p>1 analog signal output with embedded voltage and current monitoring circuits Using the Axiomatic Electronic Assistant, the user selects:</p> <ul style="list-style-type: none"> the output mode (voltage or current); and the minimum and maximum values for the output signal from the +/-10V or +/- 20 mA range. <p>Standard analog signal ranges are supported, including: 0-5V; 0-10V; +/-5V; +/-10V; 0-20mA; and 4-20 mA.</p> <p>The output can be globally enabled or disabled.</p>
Output Accuracy	<p>0.5% @ +/- 5V, +/- 10V, +/- 20 mA For all other output ranges an absolute accuracy is defined by one of the above ranges within which the output range is located. For example, for 0-5V range, the absolute accuracy is the same as for the +/- 5V range. For 0...6V range, it will be defined by the +/- 10 range.</p>
Output Resolution	0.015% (>12 bit)
Voltage Monitoring Range	+/- 12 V
Current Monitoring Range	+/- 25 mA Voltage on the load should be within the range of +/- 8 V.
Voltage and Current Monitoring Accuracy	<p>≤ 1% for voltage monitoring ≤ 2% for current monitoring</p>

Control Logic

From a software perspective, the controller consists of a set of internal functional blocks, which can be individually programmed and arbitrarily connected together to achieve the required system functionality. See Figure 1.

Each functional block is absolutely independent and has its own set of programmable parameters, or setpoints. The setpoints can be viewed and changed through CAN using the Axiomatic Electronic Assistant.

There are two types of the controller functional blocks. One type represents the controller hardware resources, for example the analog signal output block. The other type is purely logical – these functional blocks are included to program the user defined functionality of the controller. The number and functional diversity of these functional blocks are only limited by the system resources of the internal microcontroller. They can be added or modified on the customer's request to accommodate user-specific requirements.

The user can build virtually any type of a custom control by logically connecting inputs and outputs of the functional blocks. This approach gives the user an absolute freedom of customization and an ability to fully utilize the controller hardware resources in a user's application.

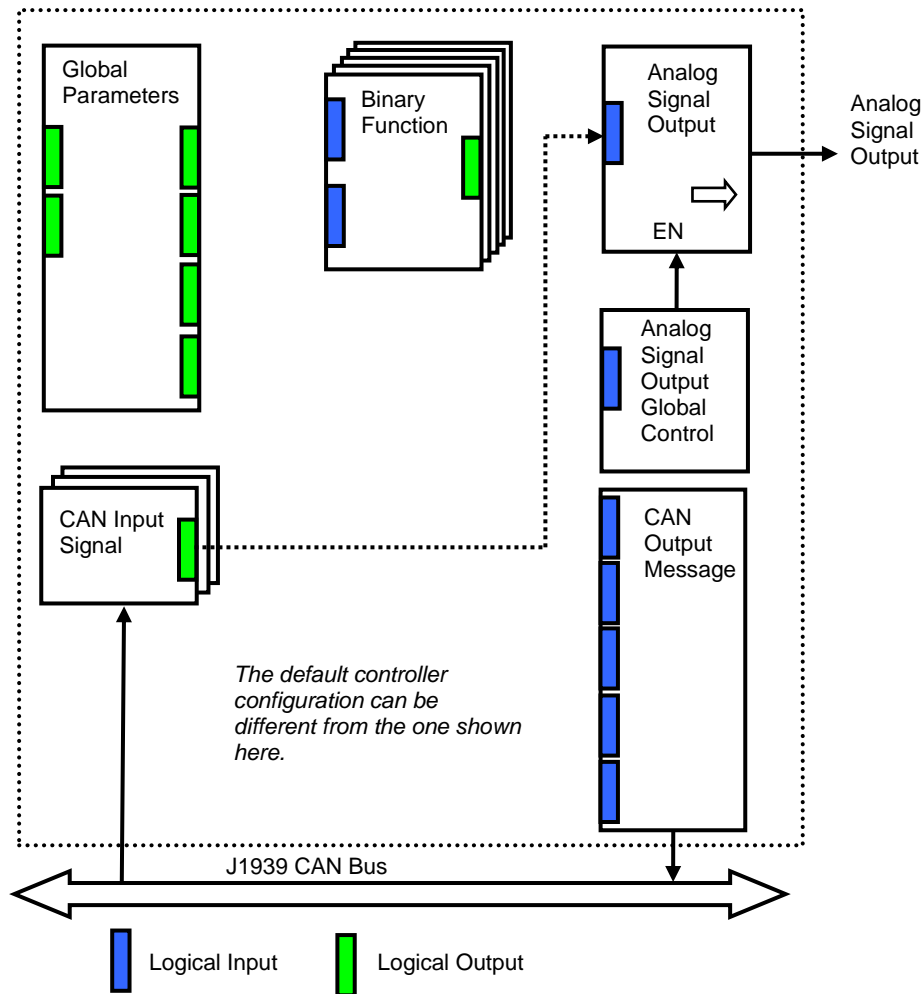

As an example, the logical output of the CAN Input Signal functional block is connected to the logical input of the Analog Signal Output functional block, providing a direct path for the CAN input signal to the controller signal output.

Figure 1. The Controller Internal Structure

Depending on the block functionality, a functional block can have logical inputs, logical outputs, or any combinations of them. The connection between logical inputs and outputs is defined by logical input setpoints. The following rules apply.

- A logical input can be connected to any logical output using a logical input setpoint.
- Two or more logical inputs can be connected to one logical output.
- Logical outputs do not have their own setpoints controlling their connectivity. They can only be chosen as signal sources by logical inputs.

Each functional block of the controller is presented by its own folder in the Setpoint File root folder in the Axiomatic Electronic Assistant.

Refer to the User Manual for more details.

General Specifications

Microcontroller	32-bit, 128 KByte flash program memory
Control Logic	Standard embedded software is provided. Refer to Figure 1.0. (Application-specific control logic or factory programmed setpoints are available on request.)
CAN	1 CAN port (SAE J1939)
Slew Rate	To adjust the controller to the CAN physical network, the slew rate can be configured as fast or slow. Refer to the User Manual for details.
Monitoring and Debugging	Besides reading application signals transmitted on the CAN bus, the controller can also transmit a CAN application message carrying signals internally generated by the controller. This feature can be used for monitoring and debugging purposes.
User Interface	Axiomatic Electronic Assistant KIT, P/Ns: AX070502 or AX070506K Updates for the Axiomatic EA are found on www.axiomatic.com under the log-in tab.
Quiescent Current	54 mA @ 12VDC, 29 mA @ 24VDC; 17 mA @ 48VDC (typical)
Settling Time	≤ 5 mSec. (0...95%)
Weight	0.65 lbs. (0.29 kg)
Operating Temperature	-40 to 85 °C (-40 to 185 °F)
Storage Temperature	-55 to 125 °C (-67 to 257°F)
Protection	IP67 PCB is conformally coated and protected by the enclosure.
Approvals	CE / UKCA marking
Enclosure and Dimensions	Encapsulated Cast Aluminum enclosure with mounting holes 4.62 x 1.91 x 1.76 inches (117.30 x 48.56 x 44.73 mm) L x W x H including integral connector

Dimensional Drawing

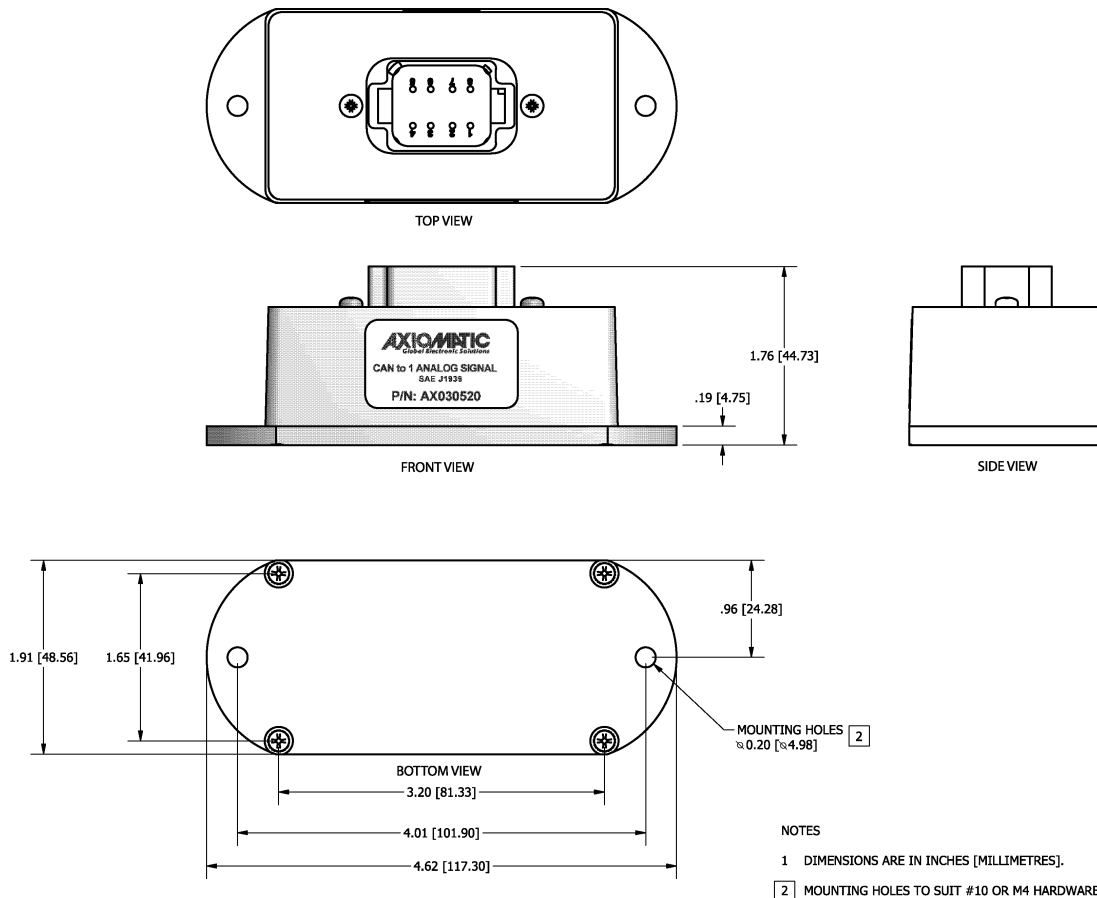

Mounting	<p>Mounting holes – The controller accepts 2 #10 or M4 screws.</p> <p>The CAN wiring is considered intrinsically safe. The power wires are not considered intrinsically safe and so in hazardous locations, they need to be located in conduit or conduit trays at all times. The module must be mounted in an enclosure in hazardous locations for this purpose.</p> <p>All field wiring should be suitable for the operating temperature range.</p> <p>Install the unit with appropriate space available for servicing and for adequate wire harness access (6 inches or 15 cm) and strain relief (12 inches or 30 cm).</p>																		
Network Termination	<p>It is necessary to terminate the network with external termination resistors. The resistors are 120 Ohm, 0.25W minimum, metal film or similar type. They should be placed between CAN_H and CAN_L terminals at both ends of the network.</p>																		
Electrical Connections	<p>8-pin plug (TE Deutsch P/N: DT15-08PA)</p> <p>Mating plug KIT: Axiomatic P/N AX070112 (includes TE Deutsch P/Ns: DT06-08SA socket, wedge W8S, 7 solid contact sockets 0462-201-16141 and 1 sealing plug 114017)</p> <p>16-18 AWG wire is recommended for use with sockets 0462-201-16141.</p> <p>Use dielectric grease on the pins when installing the controller.</p> <p>Wiring to these mating plugs must be in accordance with all applicable local codes. Suitable field wiring for the rated voltage and current must be used. The rating of the connecting cables must be at least 70°C. Use field wiring suitable for both minimum and maximum ambient temperature.</p> <table border="1" data-bbox="695 772 1170 1035"> <thead> <tr> <th>PIN #</th> <th>FUNCTION</th> </tr> </thead> <tbody> <tr> <td>1</td> <td>POWER +</td> </tr> <tr> <td>8</td> <td>POWER -</td> </tr> <tr> <td>2</td> <td>NOT USED</td> </tr> <tr> <td>7</td> <td>CAN SHIELD</td> </tr> <tr> <td>3</td> <td>ANALOG SIGNAL OUTPUT</td> </tr> <tr> <td>6</td> <td>CAN_L</td> </tr> <tr> <td>4</td> <td>GROUND</td> </tr> <tr> <td>5</td> <td>CAN_H</td> </tr> </tbody> </table>	PIN #	FUNCTION	1	POWER +	8	POWER -	2	NOT USED	7	CAN SHIELD	3	ANALOG SIGNAL OUTPUT	6	CAN_L	4	GROUND	5	CAN_H
PIN #	FUNCTION																		
1	POWER +																		
8	POWER -																		
2	NOT USED																		
7	CAN SHIELD																		
3	ANALOG SIGNAL OUTPUT																		
6	CAN_L																		
4	GROUND																		
5	CAN_H																		

CANopen® is a registered community trademark of CAN in Automation e.V.

Form: TDAX030520-01/18/2024