

# 18 Digital Inputs CAN Controller

SAE J1939 with Auto-Baud-Rate Detection  
with Axiomatic Electronic Assistant

P/N: AX030310

**Features:**

- 10 digital inputs are user selectable from the following.
  - Active High/Active Low
  - PWM signal from sensors or diesel engine ECM's
  - Frequency (Hz or RPM)
  - Counter
- 8 digital inputs are user selectable as Active High/Active Low
- 12V, 24VDC input power (nominal) with rugged surge protection
- 1 CAN (SAE J1939) with auto-baud-rate detect functionality
- CANopen® (P/N: AX030311)
- IP67
- CE/UKCA marking
- User configurable using Axiomatic Electronic Assistant



**Applications:**

- Engine controls for power generation, co-generation, stationary power
- Engine controls for commercial vehicles, off-highway equipment, etc.

**Ordering Part Numbers:**

Model P/N	Baud Rate	Standard Reference	Standard Control Logic (20 CAN transmit messages)
AX030310	SAE J1939, Auto baud rate detect	J1939/11, J1939/15.	Standard Control Logic
AX030320	SAE J1939, 250 kBit/s	J1939/11, J1939/15.	54 CAN transmit messages
AX030311	CANopen®, configurable baud rate	CANopen®	Standard Control Logic

Axiomatic Electronic Assistant Configuration KIT, P/Ns: **AX070502**, **AX070505K**, or **AX070506K**  
 Accessories: **PL-DTM06-12SA-12SB** Mating Plug Kit

## BLOCK DIAGRAM

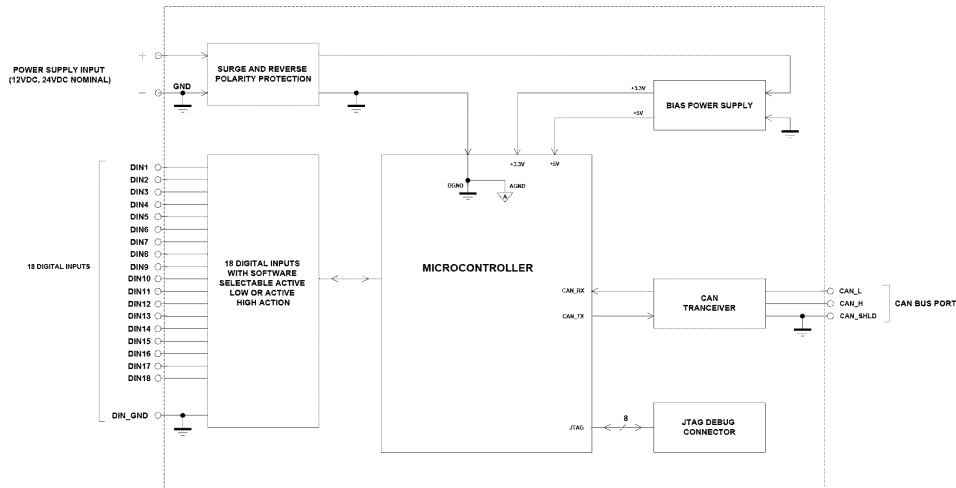

### Technical Specifications:

Specifications are indicative and subject to change. Actual performance will vary depending on the application and operating conditions. Users should satisfy themselves that the product is suitable for use in the intended application. All our products carry a limited warranty against defects in material and workmanship. Please refer to our Warranty, Application Approvals/Limitations and Return Materials Process as described on <https://www.axiomatic.com/service/>.

### Input Specifications

Power Supply Input - Nominal	12V, 24VDC nominal (8...36VDC power supply range)
Protection	Surge and reverse polarity protection are provided.
All Inputs	Up to 18 digital inputs are selectable by the user. Refer to Table 1.0.
Input Protection	Full protection to all other physical pins (any other input or power terminal).
CAN Commands	SAE J1939 {CANopen® model AX030311}
Ground Connection	1 Digital GND connection is provided.

Table 1.0 - Inputs	
Digital Inputs	<p>Up to 18 digital inputs are available.</p> <p>The first 10 digital inputs can be configured for any one of the following options.</p> <ul style="list-style-type: none"> <li>• Disable Input</li> <li>• Digital Input</li> <li>• PWM signal input (1-10,000 Hz, 0-100% D.C.)</li> <li>• Frequency Input (Hz or RPM) (50 to 10,000 Hz, 50 mV-3V RMS)*</li> <li>• 16-bit Counter Input</li> </ul> <p>The last 8 digital inputs can be configured for any one of the following options.</p> <ul style="list-style-type: none"> <li>• Disable Input</li> <li>• Digital Input</li> </ul> <p>Threshold 3.5V Hysteresis 0.4V Pull up/ Pull down 10 KOhm Input voltage maximum is 30Vdc.</p>
Input Accuracy	<p>PWM, single channel: +/- 0.05% to +/- 1.25% (over the 500 Hz to 10 kHz range)</p> <p>Frequency/RPM, single channel: +/- 1%</p> <p>16-bit counter, single channel: +/- 3 mSec (@50 Hz)</p>
Input Resolution	<p>PWM, single channel: +/- 0.05% to +/- 1.25%, 0 decimal place resolution</p> <p>Frequency/RPM (single channel)</p> <p>0.5 Hz to 50 Hz: +/- 0.01Hz, 0 decimal place resolution</p> <p>50 Hz to 10kHz: +/- 1Hz, 0 decimal place resolution</p> <p>16-bit counter, single channel: 1 pulse resolution</p>

### Output Specifications

CAN Messages	SAE J1939
--------------	-----------

## General Specifications

Microcontroller	STM32F205RET6
Control Logic	Standard embedded software ( <i>Application-specific logic is available on request.</i> ) Configurable properties of the Electronic Control Unit (ECU) are divided into function blocks, namely Input Function Block, Diagnostic Function Block, Lookup Table Function Block, Programmable Logic Function Block, Math Function Block, CAN Transmit Message Function Block and CAN Receive Function Block. Refer to the User Manual for details. Models AX030310, AX030310-01 and AX030310-02 support 20 CAN transmit messages. Model AX030320 supports 54 CAN transmit messages.
User Interface (PC-based)	Axiomatic Electronic Assistant for <i>Windows</i> operating systems. It comes with a royalty-free license for use. The Axiomatic Electronic Assistant requires an Axiomatic USB-CAN converter to link the device's CAN port to a <i>Windows</i> -based PC. This is included in the Configuration KIT, P/Ns: AX070502, AX070505K, AX070506K.
CAN Communications	1 CAN port (SAE J1939) 250kbit/s, 500kbit/s, 667kbit/s, 1Mbit/s. Auto-Baud-Rate Detection
Quiescent Current Draw	13.71 mA @ 24V 24.15 mA @ 12V 31.68 mA @ 9V
Compliance	CE/UKCA mark EMC Directive RoHS Directive Exempt from Low Voltage Directive
Vibration	Random Vibration: 7.7 Grms peak Sinusoidal Component: 10 g peak Based on MIL-STD-202G, Methods 204G and 214A
Shock	50 g half sine pulse, 6 x 6ms per axis Based on MIL-STD-202G, Method 213B, Test Condition A
Network Termination	It is necessary to terminate the network with external termination resistors. The resistors are 120 Ohm, 0.25W minimum, metal film or similar type. They should be placed between CAN_H and CAN_L terminals at both ends of the network.
Operating Temperature	-40 to 85°C (-40 to 185°F)
Storage Temperature	-50 to 125°C (-58 to 257°F)
Protection	IP67, PCB is conformal coated and protected by the enclosure.
Weight	0.50 lb. (0.23 kg)
Enclosure and Dimensions	High Temperature Nylon Enclosure – (equivalent TE Deutsch P/N: EEC-325X4B) Flammability Rating: UL 94V-0 Refer to dimensional drawing for dimensions.

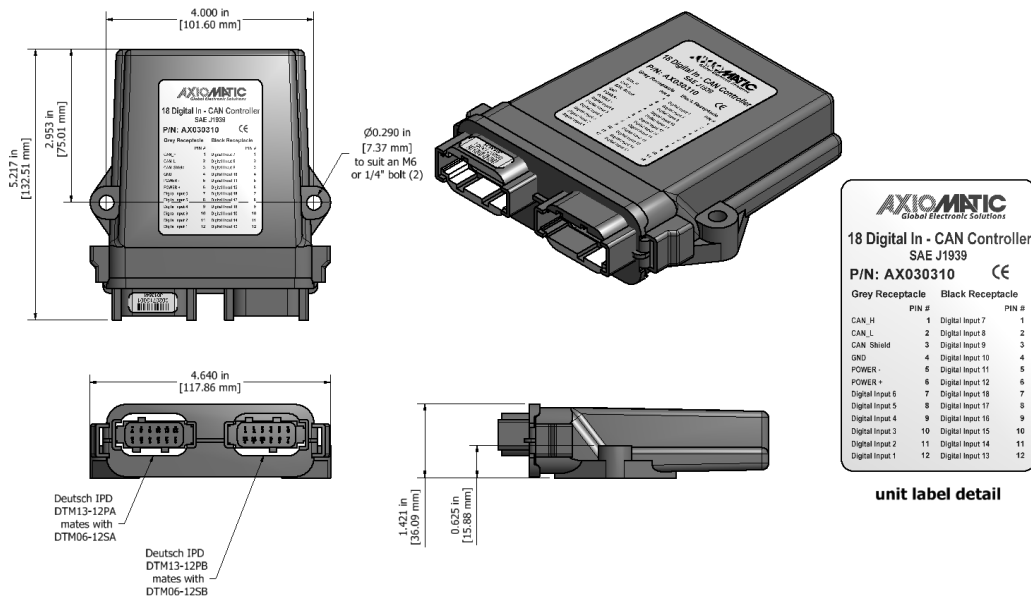
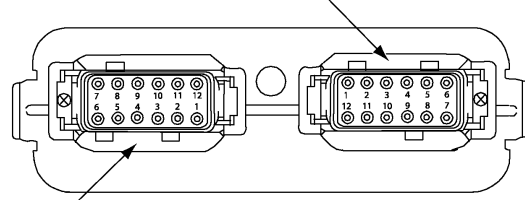

Figure 1.0 - Dimensional Drawing

Electrical Connections

24-pin receptacle (equivalent TE Deutsch P/N: DTM13-12PA-12PB-R008)  
 Mating plug: equivalent to the TE Deutsch P/Ns DTM06-12SA and DTM06-12SB,  
 with 2 wedgelocks (WM12S) and 24 contacts (0462-201-20141).  
 20 AWG wire is recommended for use with contacts 0462-201-20141.

**Key Arrangement B (black)**



**Key Arrangement A (grey)**

**FRONT VIEW 24 PIN RECEPTACLE**

Grey Connector		Black Connector	
1	CAN_H	1	Digital Input 7
2	CAN_L	2	Digital Input 8
3	CAN_Shield	3	Digital Input 9
4	GND	4	Digital Input 10
5	Power -	5	Digital Input 11
6	Power+	6	Digital Input 12
7	Digital Input 6	7	Digital Input 18
8	Digital Input 5	8	Digital Input 17
9	Digital Input 4	9	Digital Input 16
10	Digital Input 3	10	Digital Input 15
11	Digital Input 2	11	Digital Input 14
12	Digital Input 1	12	Digital Input 13

CANopen® is a registered community trademark of CAN in Automation e.V.

Form: TDAX030310-05/31/23