

TECHNICAL DATASHEET #TDAX022001  
**Dual Output Valve Controller**

1 Universal Input  
+5V reference  
CANopen®

P/N: AX022001

**Features:**

- 1 universal signal input
- 2 proportional or on/off outputs up to 3 A
- User programmable functionality
- 8...36VDC (12V or 24V nominal)
- +5V, 10 mA reference to power a potentiometer or low-power transducer
- 1 CANopen® port
- Aluminum enclosure with integral 12-pin connector
- IP67
- CE Marking



The Dual 3A Output Valve Controller is designed for extremely versatile control of the two proportional outputs to directly drive coils or other loads. Its flexible circuit design gives the user a wide range of configurable input or output types. The sophisticated control algorithms allow the user to program the controller for a wide range of applications without the need for custom software.

The two universal outputs can be setup to drive: proportional current (up to 3A each); hotshot digital current; proportional voltage (up to supply); proportional PWM; or straight on/off digital loads. Both outputs are high-side driven (sourcing) outputs.

The controller also has one fully programmable universal input that can be setup to read: voltage; current; resistive; frequency; or digital input signals. It also has a single +5Vref that can source up to 10mA to provide a reference for a potentiometer or low-power transducer.

The controller has a number of built-in protection features that can shut off the outputs in adverse conditions. They include hardware shutoffs to protect the circuits from being damaged as well as software shutdown features that can be enabled in safety critical systems when an input or CAN fault is detected.

The controller architecture consists of a set of internal functional blocks, which can be individually programmed and arbitrarily connected together to achieve the required system functionality for a specific application. All objects are user configurable using standard commercially available tools that can interact with a CANopen® Object Dictionary via an .EDS file.

**Ordering Part Numbers:**

CANopen® Dual 3A Output Valve Controller: **AX022001**

EDS File, User Manual: **CD-AX022001**

Accessories: **AX070105** Mating Plug Kit (DT06-12SA, W12S, 12 0462-201-16141, 3 plugs)

# BLOCK DIAGRAM

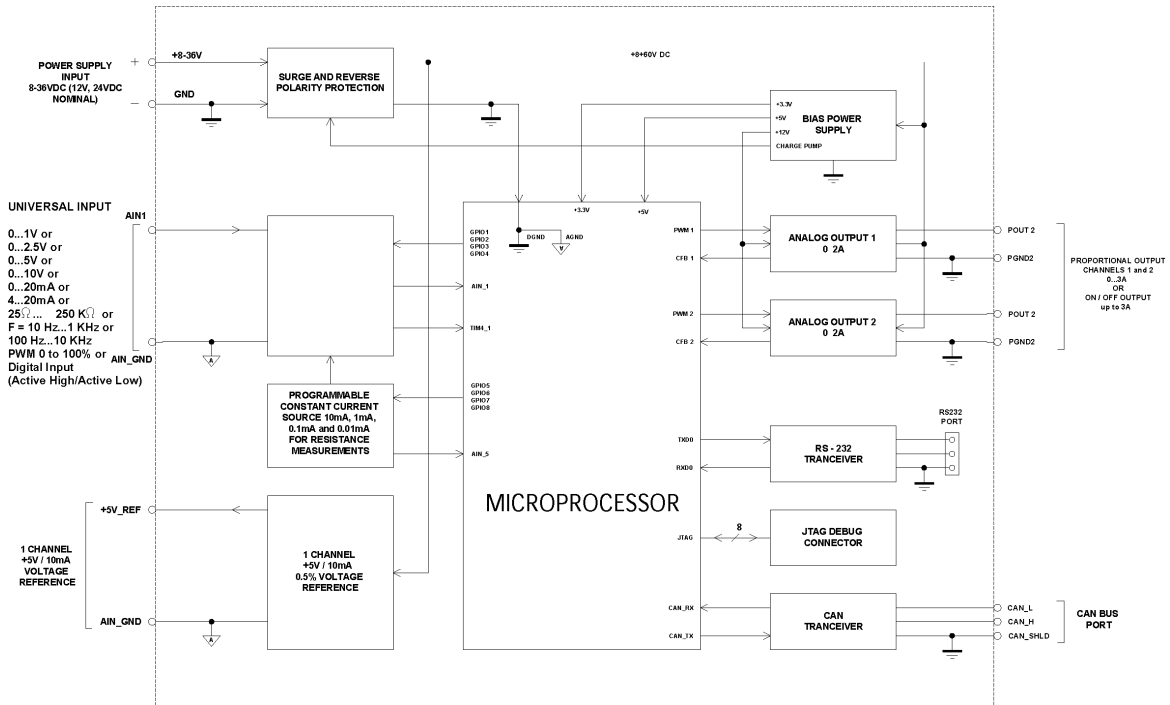

## Technical Specifications:

### Inputs

Power Supply Input	12V or 24V nominal (8...36 VDC power supply range)
Protection	Reverse polarity protection is provided. Overvoltage protection up to 38V is provided. Overvoltage (undervoltage) shutdown of the output load is provided.
CAN	CANopen® Command
Universal Signal Input	Refer to Table 1.0. The input is user selectable.

Table 1.0 – Input – User Selectable Options	
Analog Input Functions	Voltage Input, Current Input or Resistive Input
Voltage Input	0-1V (Impedance 1 MOhm) 0-2.5V (Impedance 1 MOhm) 0-5V (Impedance 200 KOhm) 0-10V (Impedance 133 KOhm)
Current Input	0-20 mA (Impedance 124 Ohm) 4-20 mA (Impedance 124 Ohm)
Resistive Input	25Ω to 250 kΩ
Digital Input Functions	Discrete Input, PWM Input, Frequency Input, RPM
Digital Input Level	5V CMOS Active High or Active Low Normal, Inverse or Latched (push-button) response
PWM Input	0 to 100% 10 Hz to 1kHz 100 Hz to 10 kHz
Frequency Input	10 Hz to 1kHz 100 Hz to 10 kHz
Digital Input	Active High, Active Low
Input Impedance	Selectable 10KOhm pull down, 10KOhm pull up to +5V
Input Accuracy	≤ 1% full scale error (all types)
Input Resolution	12-bit
Error Detection/Reaction	Out of range High and Low detection EMCY code generation (object 1003h) and fault reaction possible (object 1029h) Output(s) shutdown function can be enabled.

## Outputs

CAN	CANopen® Messages
Output	<p>2 Proportional or On/Off Outputs (Up to 3A)            High Side Switch (sourcing output), Grounded Load            Current Sensing for close-loop control, current feedback on object 2370h</p> <p>The user can select the following options for output using a configuration tool.</p> <ul style="list-style-type: none"> <li>• Discrete Output (On/Off)</li> <li>• Hotshot On/Off</li> <li>• Output Current</li> <li>• Output Current - PID loop*, with current sensing</li> <li>• Output Voltage</li> <li>• Output PWM Duty Cycle</li> </ul> <p>*Factory calibrated and user configurable</p>
Output Accuracy	<p>Output Current mode <math>\leq 2\%</math> full scale error            Output Voltage mode <math>\leq 3\%</math> full scale error            Output PWM Duty Cycle mode <math>\leq 3\%</math> full scale error</p>
Error Detection/Reaction	EMCY code generation (object 1003h) and fault reaction is possible (object 1029h) when an open or short circuit is detected at the output (current mode only).
Independence	<p>Outputs are fully independent from one another with two exceptions:</p> <ol style="list-style-type: none"> <li>both use the same AO Dither Frequency (object 2320h sub-index 1);</li> <li>both use the same AO Output Frequency (object 2380h sub-index 1).</li> </ol>
Voltage Reference	<p>+5V, 10 mA, 0.5%            Short circuit protected (current limited to 22-24 mA)            Protected from connection to the power supply rail.</p>
Protection for Output + Terminal	Fully protected against short circuit to ground and short circuit to power supply rail. Unit will fail safe in the case of a short circuit condition, self-recovering when the short is removed.

## General Specifications

Microprocessor	32-bit, 128 KByte flash program memory						
Control Logic	<p>Standard embedded software is provided. Refer to UMAX022001 for details.            All objects are user configurable using standard commercially available tools that can interact with a CANopen® Object Dictionary via an .EDS file.  <i>Application-specific control logic or factory programmed setpoints are available on request.</i></p>						
Communications	<p>1 CAN port (CANopen®)</p> <p>The controller's object dictionary is compatible with the CiA DS-404 device profile. In addition to the standard objects for this device profile, the controller also includes a number of manufacturer specific objects to extend the functionality beyond that of the basic profile.</p> <p>The Axiomatic AX022001 is compliant with the following CAN in Automation (CiA) standards.</p> <table border="1" data-bbox="560 1291 1339 1470"> <tr> <td>[DS-301]</td> <td>CiA DS-301 V4.02 – CANopen® Application Layer and Communication Profile. CAN in Automation 2002</td> </tr> <tr> <td>[DS-404]</td> <td>CiA DS-404 V1.2 – Device Profile for Measurement Devices and Closed-Loop Controllers. CAN in Automation 2002</td> </tr> <tr> <td>[DS-305]</td> <td>CiA DS-305 V2.0 – Layer Setting Service (LSS) and Protocols. CAN in Automation 2006</td> </tr> </table>	[DS-301]	CiA DS-301 V4.02 – CANopen® Application Layer and Communication Profile. CAN in Automation 2002	[DS-404]	CiA DS-404 V1.2 – Device Profile for Measurement Devices and Closed-Loop Controllers. CAN in Automation 2002	[DS-305]	CiA DS-305 V2.0 – Layer Setting Service (LSS) and Protocols. CAN in Automation 2006
[DS-301]	CiA DS-301 V4.02 – CANopen® Application Layer and Communication Profile. CAN in Automation 2002						
[DS-404]	CiA DS-404 V1.2 – Device Profile for Measurement Devices and Closed-Loop Controllers. CAN in Automation 2002						
[DS-305]	CiA DS-305 V2.0 – Layer Setting Service (LSS) and Protocols. CAN in Automation 2006						
User Interface	<p>Not supplied            Any CANopen® service tool can act as a PC-based user interface to configure and monitor Axiomatic CANopen® products.</p>						
Network Termination	It is necessary to terminate the network with external termination resistors. The resistors are 120 Ohm, 0.25W minimum, metal film or similar type. They should be placed between CAN_H and CAN_L terminals at both ends of the network.						
Typical Quiescent Current	<p>41 mA @ 12 V            29 mA @ 24 V            21 mA @ 48 V</p>						
Operating Conditions	-40 to 85 °C (-40 to 185 °F)						
Packaging	<p>Aluminum enclosure, integral connector (TE Deutsch equivalent)            Encapsulated            Refer to the dimensional drawing.</p>						
EMC Compliance	CE marking						
Protection	<p>IP67 rating for the product assembly            NOTE: TE Deutsch connectors are rated at IP67 for submersion (3 ft., 0.9 m).</p>						
Weight	0.70 lb. (0.32 kg)						

## Dimensional Drawing

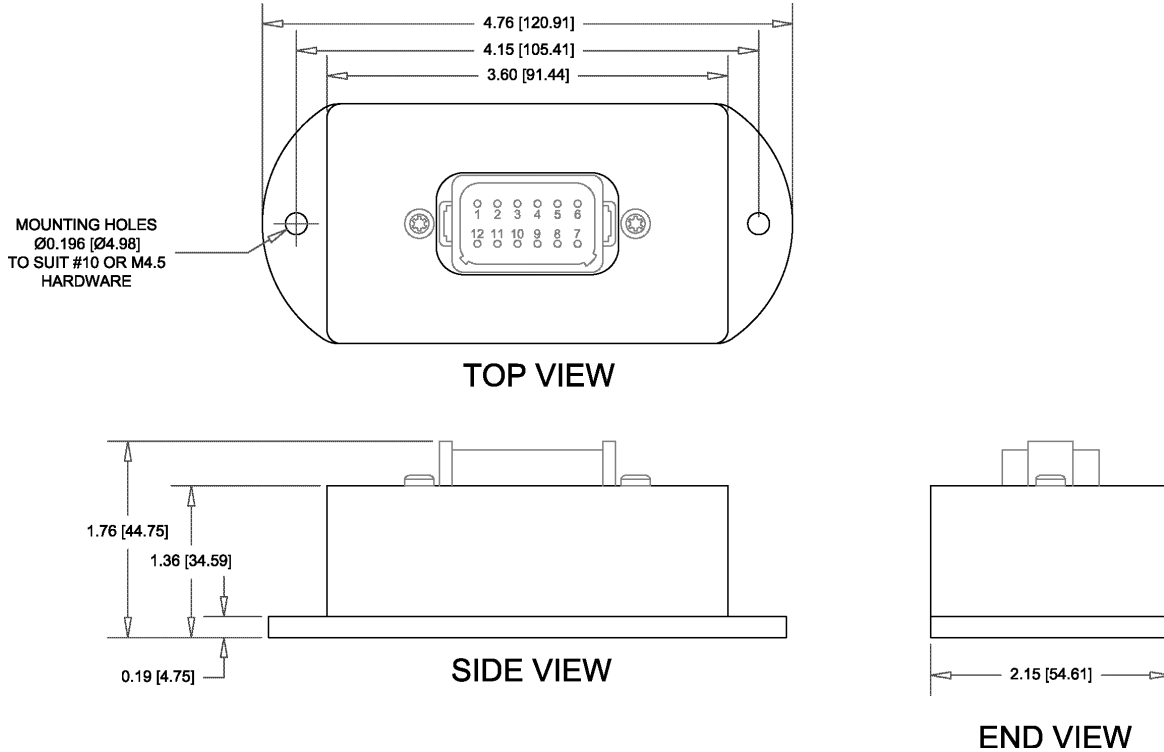

<p>Electrical Connections</p>	<p>12 pin connector (equivalent TE Deutsch P/N: DT15-12PA) A mating plug kit is available as Axiomatic P/N: <b>AX070105</b>.</p> <table border="1" data-bbox="544 1039 971 1457"> <thead> <tr> <th colspan="2">CAN and I/O Connector</th> </tr> <tr> <th>Pin #</th> <th>Description</th> </tr> </thead> <tbody> <tr><td>1</td><td>Output 1</td></tr> <tr><td>2</td><td>Output 1 GND</td></tr> <tr><td>3</td><td>Power +</td></tr> <tr><td>4</td><td>CAN Shield</td></tr> <tr><td>5</td><td>CAN LO</td></tr> <tr><td>6</td><td>CAN Hi</td></tr> <tr><td>7</td><td>+5V reference</td></tr> <tr><td>8</td><td>Input GND</td></tr> <tr><td>9</td><td>Universal Input 1</td></tr> <tr><td>10</td><td>Power GND</td></tr> <tr><td>11</td><td>Output 2 GND</td></tr> <tr><td>12</td><td>Output 2</td></tr> </tbody> </table>	CAN and I/O Connector		Pin #	Description	1	Output 1	2	Output 1 GND	3	Power +	4	CAN Shield	5	CAN LO	6	CAN Hi	7	+5V reference	8	Input GND	9	Universal Input 1	10	Power GND	11	Output 2 GND	12	Output 2
CAN and I/O Connector																													
Pin #	Description																												
1	Output 1																												
2	Output 1 GND																												
3	Power +																												
4	CAN Shield																												
5	CAN LO																												
6	CAN Hi																												
7	+5V reference																												
8	Input GND																												
9	Universal Input 1																												
10	Power GND																												
11	Output 2 GND																												
12	Output 2																												
<p>Installation</p>	<p>Mounting holes sized for #10 or M4.5 bolts. The bolt length will be determined by the end-user's mounting plate thickness. The mounting flange of the controller is 0.19 inches (4.75 mm) thick.</p> <p>If the module is mounted without an enclosure, it should be mounted to reduce the likelihood of moisture entry. Install the unit with appropriate space available for servicing and for adequate wire harness access (6 inches or 15 cm) and strain relief (12 inches or 30 cm).</p> <p>The CAN wiring is considered intrinsically safe. The power wires are not considered intrinsically safe and so in hazardous locations, they need to be located in conduit or conduit trays at all times. The module must be mounted in an enclosure in hazardous locations for this purpose.</p> <p>All field wiring should be suitable for the operating temperature range of the module.</p> <p>All chassis grounding should go to a single ground point designated for the machine and all related equipment.</p>																												

## CONTROL ARCHITECTURE

The controller consists of a set of internal functional blocks, which can be individually programmed and arbitrarily connected together to achieve the required system functionality for a specific application. Each functional block is absolutely independent and has its own set of programmable parameters, or object dictionary entries. All objects are user configurable using standard commercially available tools that can interact with a CANopen® Object Dictionary via an .EDS file.

Sophisticated control algorithms allow for open or closed loop drive of the proportional outputs. It can be operated as either a self-contained control system, driving the outputs directly from the on-board inputs, and/or it can be integrated into a CANopen® network of controllers. All I/O and logical function blocks on the unit are inherently independent from one another, but can be programmed to interact in a large number of ways. Figure 1 shows the logical function blocks (software) available on the AX022001.

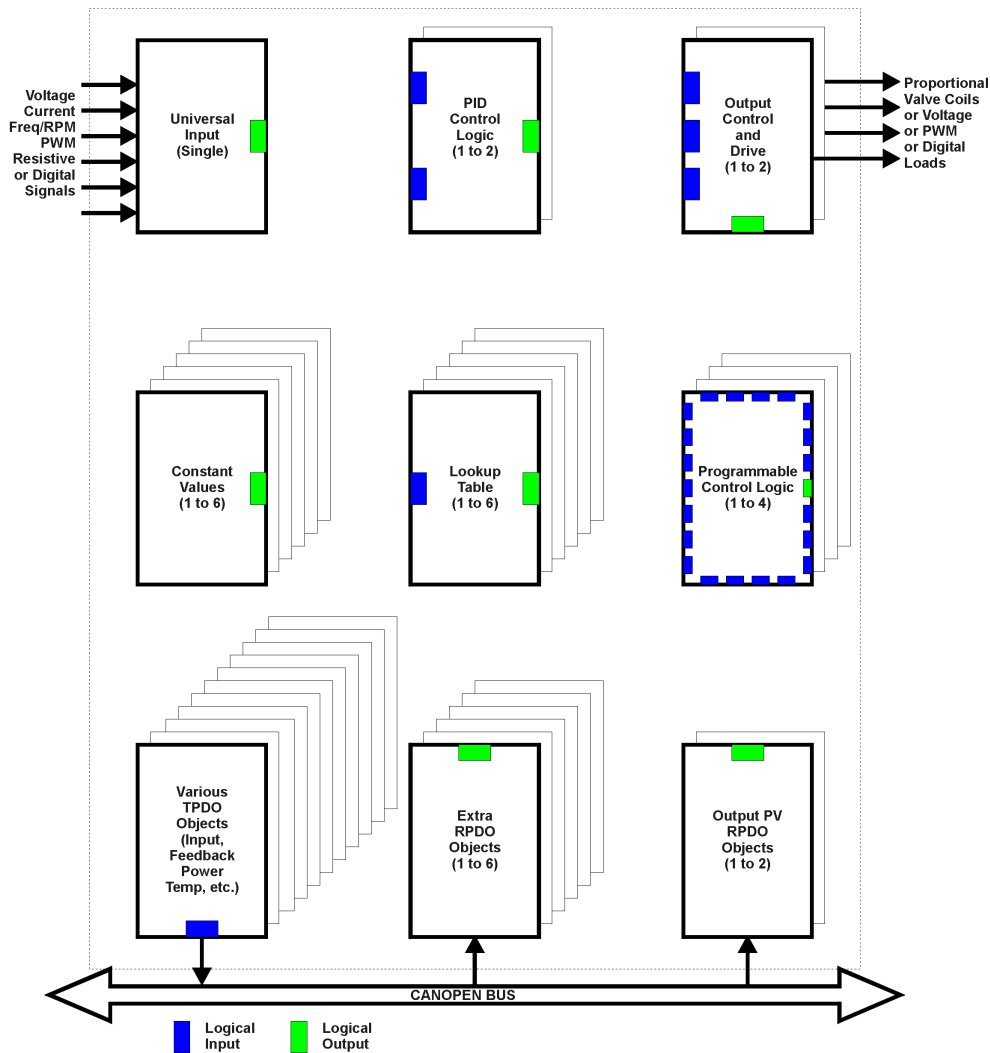

**Figure 1 –Logic Functional Block Diagram**

*Specifications are indicative and subject to change. Actual performance will vary depending on the application and operating conditions. Users should satisfy themselves that the product is suitable for use in the intended application. All our products carry a limited warranty against defects in material and workmanship. Please refer to our Warranty, Application Approvals/Limitations and Return Materials Process as described on <https://www.axiomatic.com/service/>.*

CANopen® is a registered community trademark of CAN in Automation e.V.