

Ø0.217 in [Ø5.51 mm] to suit an M5 or #10 bolt (2)

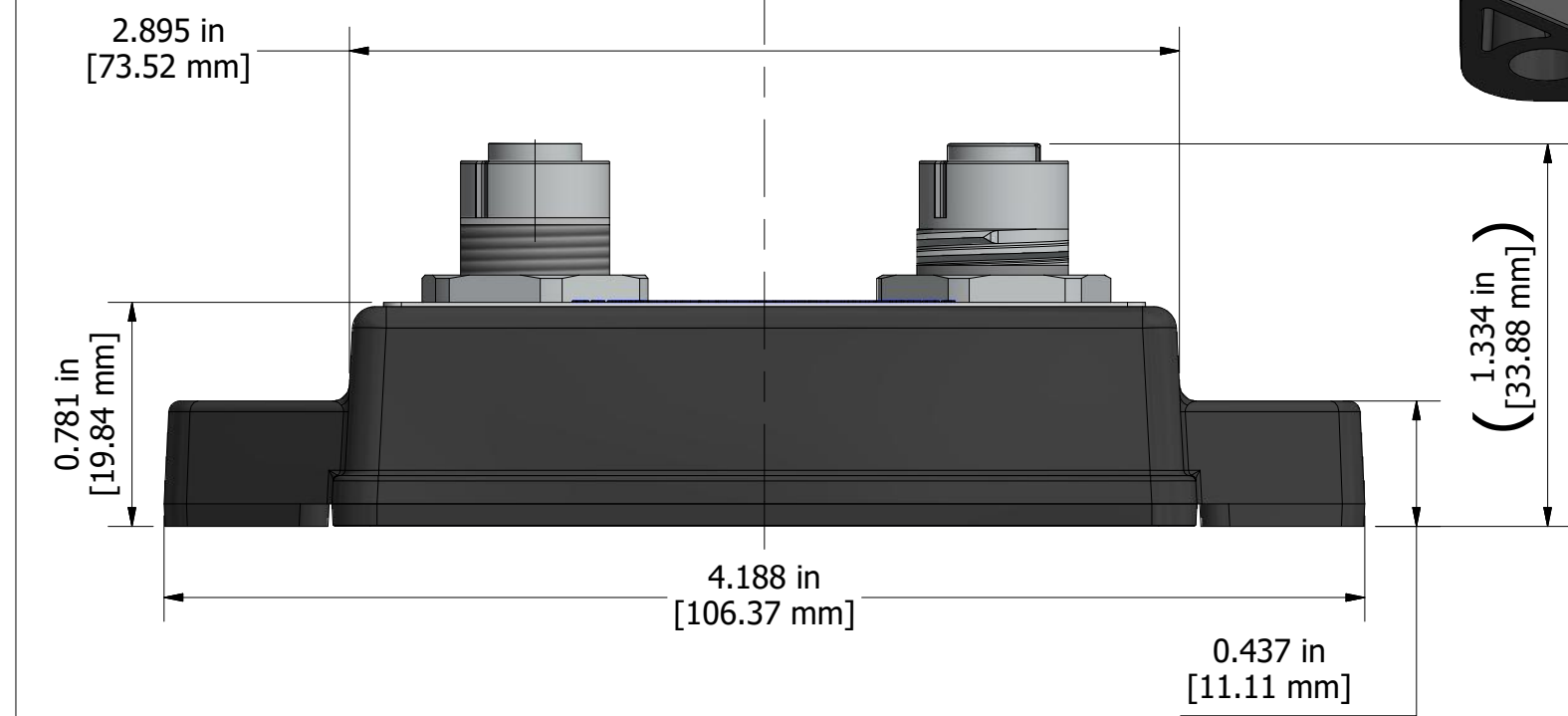
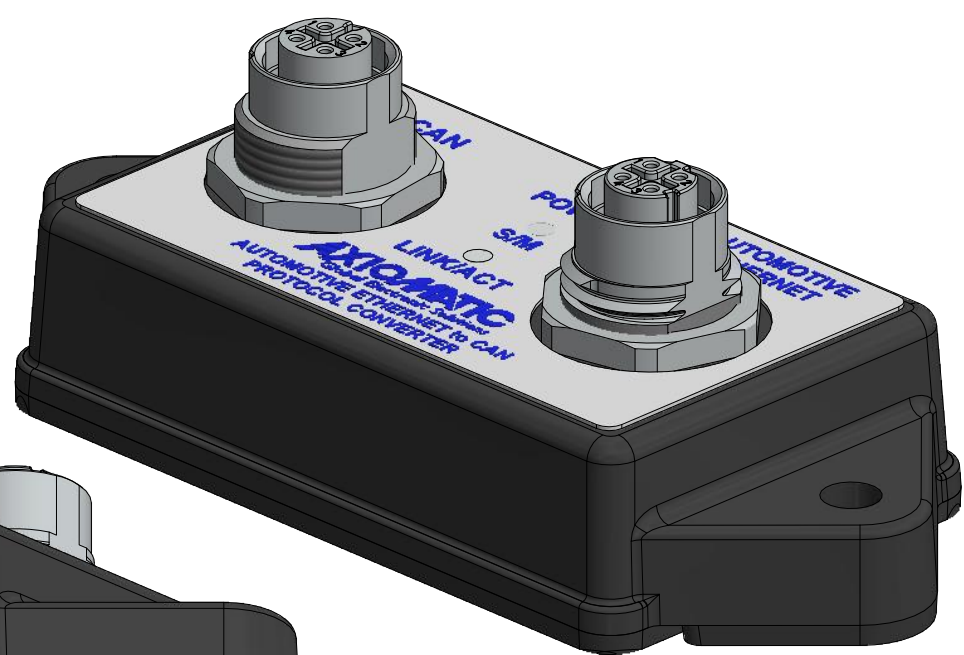
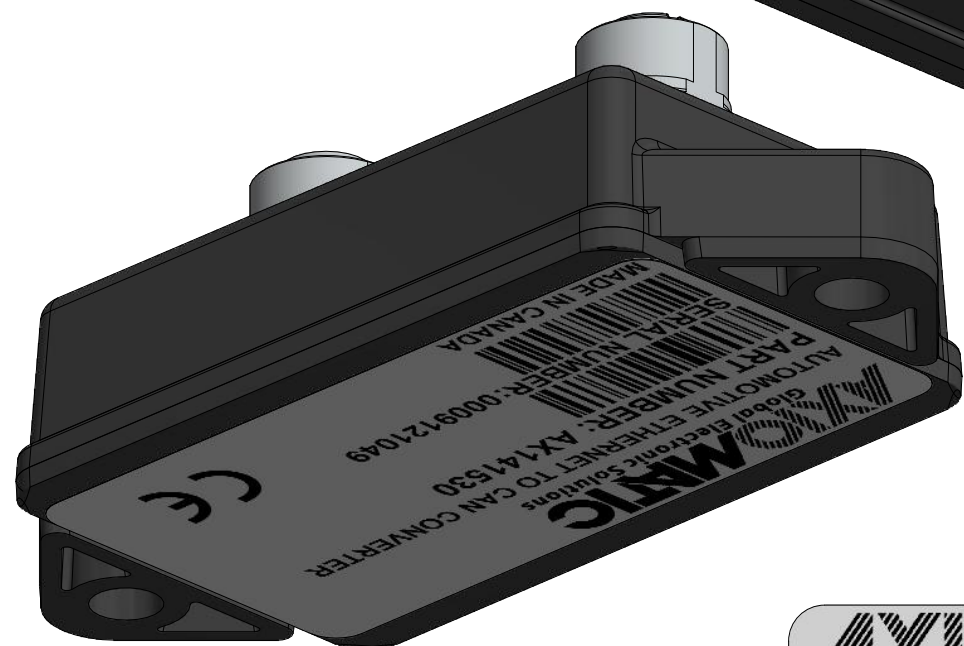

AXIOMATIC
Global Electronic Solutions

AUTOMOTIVE ETHERNET TO CAN CONVERTER

PART NUMBER: AX141530

SERIAL NUMBER: 0009121049

MADE IN CANADA

CE

device plate label

<small>PROPRIETARY</small> THE INFORMATION CONTAINED IN THIS DRAWING IS CONFIDENTIAL AND PROPRIETARY AND REMAINS THE EXCLUSIVE PROPERTY OF AXIOMATIC TECHNOLOGIES CORPORATION. THIS DRAWING MAY NOT BE USED, REPRODUCED IN WHOLE OR IN PART, NOR REVEALED TO OTHERS WITHOUT THE PRIOR WRITTEN CONSENT OF AXIOMATIC TECHNOLOGIES CORPORATION. BY ACCEPTANCE OF THIS DRAWING, THE BEARER AGREES TO THESE CONDITIONS.		<small>AXIOMATIC TECHNOLOGIES CORPORATION</small> AXIOMATIC Global Electronic Solutions 5915 WALLACE ST. MISSISSAUGA, ON CANADA L4Z1Z8 905-602-9270						
TOLERANCES fabrication X.XXX +/- 0.015 X.XX +/- 0.031 X.X +/- 0.031 fractional +/- 0.031 machining X.XXX +/- 0.005 X.XX +/- 0.010 X.X +/- 0.015 fractional +/- 0.031		MATERIAL PA66-30%GF ultrasonically welded housing, polycarbonate overlay, UL94-V0 rated	DRAWN TF CHECKED DATE APPROVED DATE	DATE 2021-09-20	TITLE CAN to Automotive Ethernet Converter	DWG REV D1	DWG NO AX141530-MD	PART REV 1
		SCALE full	PART NO AX141530	SHEET 1 of 1				