

4

3

2

1

REVISION HISTORY

REV	DESCRIPTION	DATE	APPROVED
R1-D1	initial release	November 21-2023	TM
A-D1	release to production (ECN24-0038)	August 23-2024	GDV

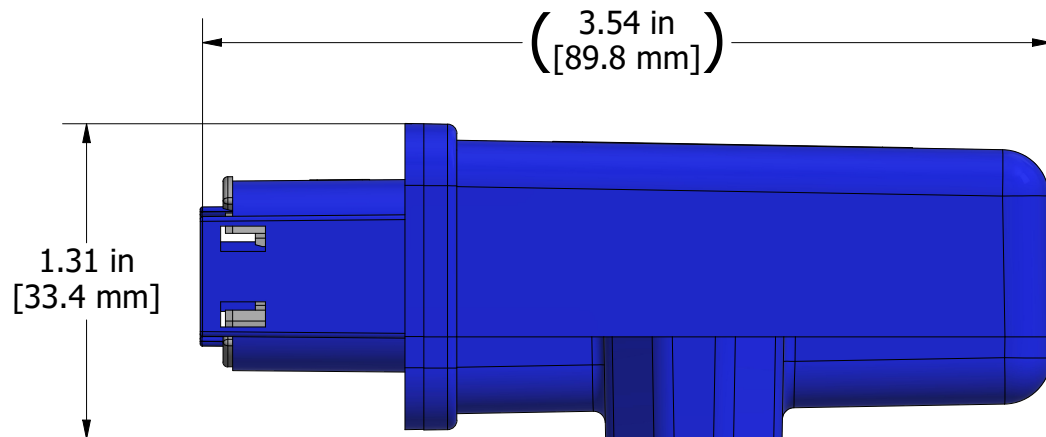
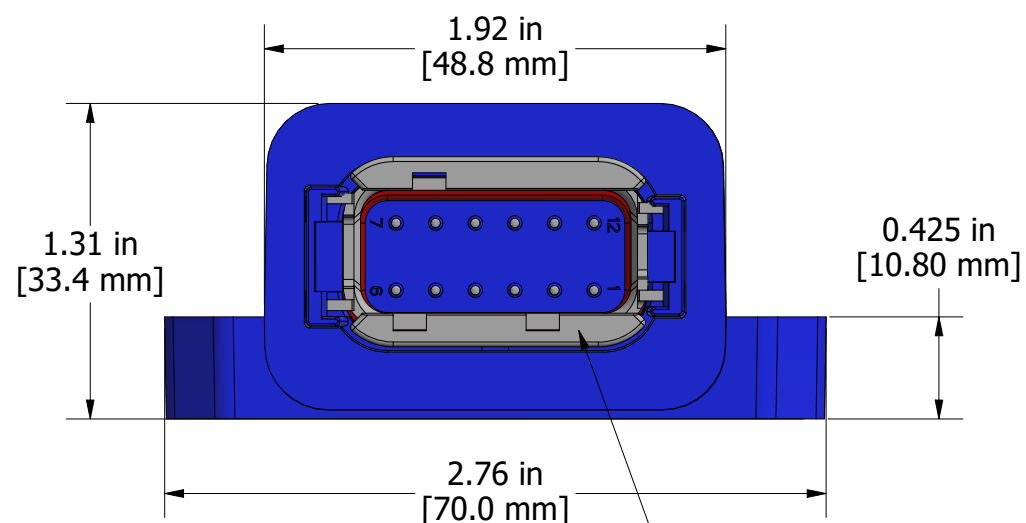
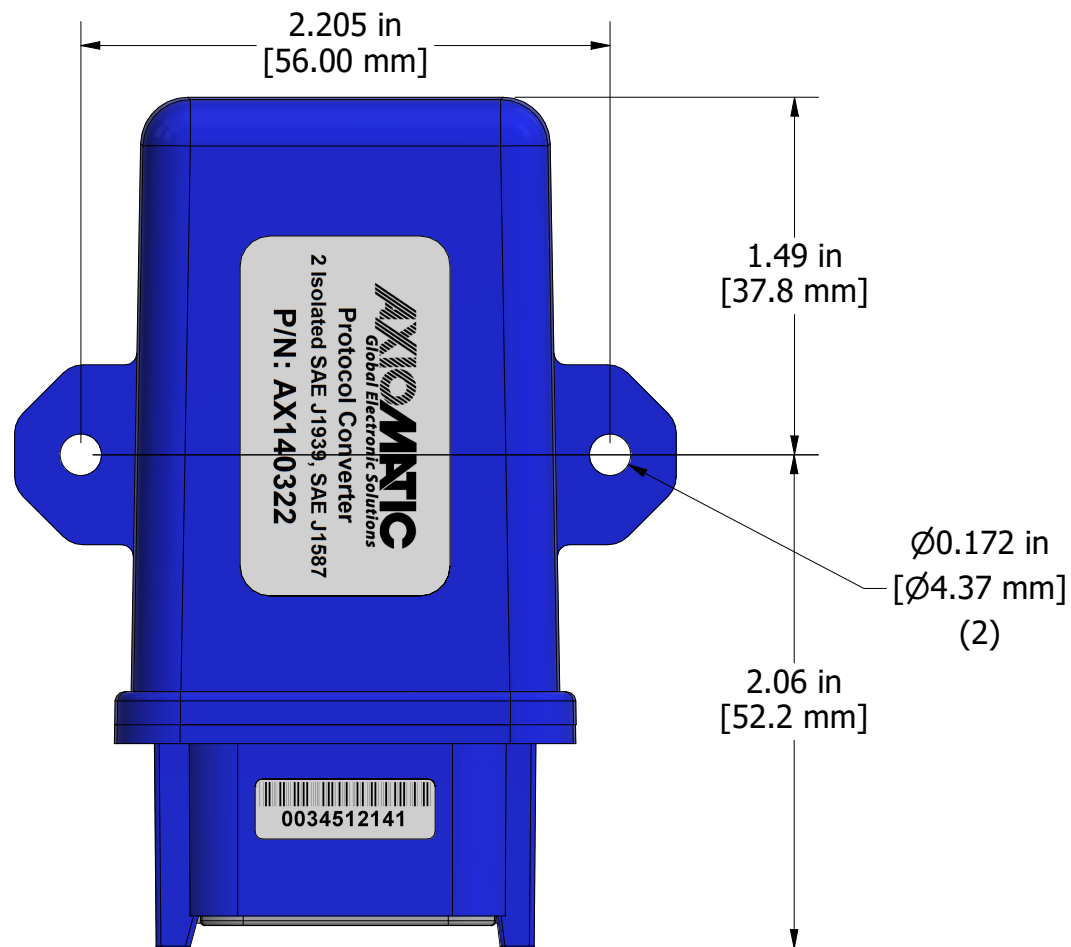

unit label

TE Deutsch DTM04-12PA receptacle mates with TE Deutsch DTM06-12SA

DIMENSIONS ARE IN inches [mm]		
Unless otherwise noted, tolerances as stated.		
TOLERANCES	FABRICATION	MACHINING/CASTING/MOLDING
X.XXX" [X.XX mm]	± 0.015" [0.38 mm]	± 0.005" [0.13 mm]
X.XX" [X.X mm]	± 0.03" [0.7 mm]	± 0.008" [0.2 mm]
X.X" [X mm]	± 0.06" [1.5 mm]	± 0.03" [0.7 mm]
	ANGLES ± 1.0	ANGLES ± 0.5
		others ISO 2768-2 class K

PROPRIETARY				AXIOMATIC TECHNOLOGIES CORPORATION			
THE INFORMATION CONTAINED IN THIS DRAWING IS CONFIDENTIAL AND PROPRIETARY AND REMAINS THE EXCLUSIVE PROPERTY OF AXIOMATIC TECHNOLOGIES CORPORATION. THIS DRAWING MAY NOT BE USED, REPRODUCED IN WHOLE OR IN PART, NOR REVEALED TO OTHERS WITHOUT THE PRIOR WRITTEN CONSENT OF AXIOMATIC TECHNOLOGIES CORPORATION. BY ACCEPTANCE OF THIS DRAWING, THE BEARER AGREES TO THESE CONDITIONS.							
MATERIAL NA	DRAWN TF	DATE 2023-11-21	TITLE CAN-Modbus RTU Converter, 2 Isolated SAE J1939, custom setpoints				
FINISH NA	CHECKED AW	DATE 2024-09-17	DWG REV D1	DWG NO AX140322-MD	PART REV A		
THIRD ANGLE PROJECTION	TOOL INVENTOR SIZE B	APPROVED GDV	DATE 2024-09-17	SCALE 2	PART NO AX140322	SHEET 1 of 1	

4

3

2

1