

4

3

2

1

REVISION HISTORY

| REV | DESCRIPTION | DATE | APPROVED |
|------|-----------------|------------------|----------|
| A-D1 | initial release | December 18-2023 | TM |

PARTS LIST

| ITEM | QTY | PART NUMBER | DESCRIPTION |
|------|-----|--------------------|----------------------------------|
| 1 | 1 | MG-21008-01 | RS422-CAN Converter |
| 2 | 1 | LBM-AX140321-01-R1 | unit label |
| 3 | 1 | DEUT 1010-042-1206 | DTM series gasket, red silicone |
| 4 | 1 | DEUT 1011-052-1205 | DTM series keyed gasket retainer |

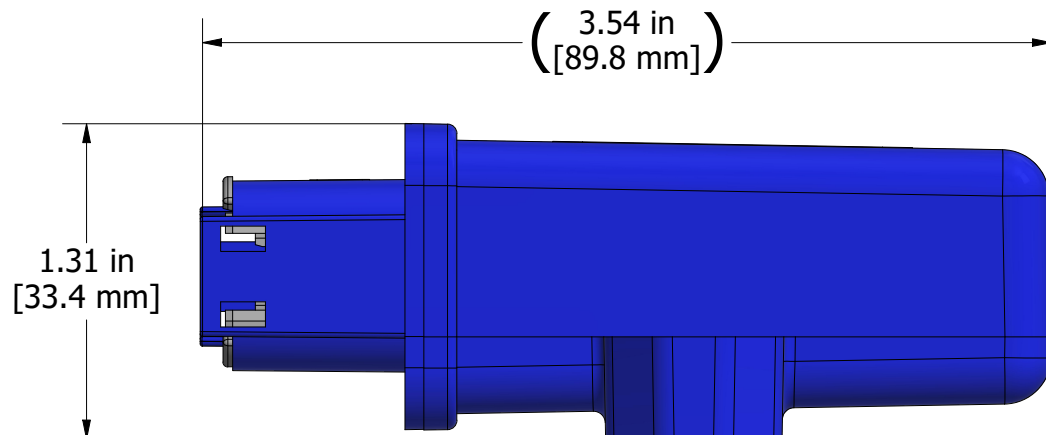
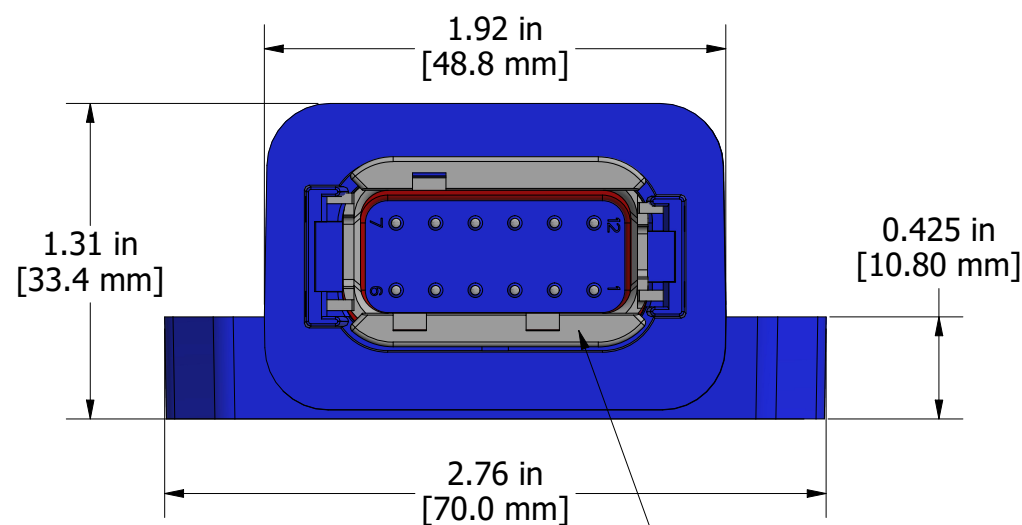
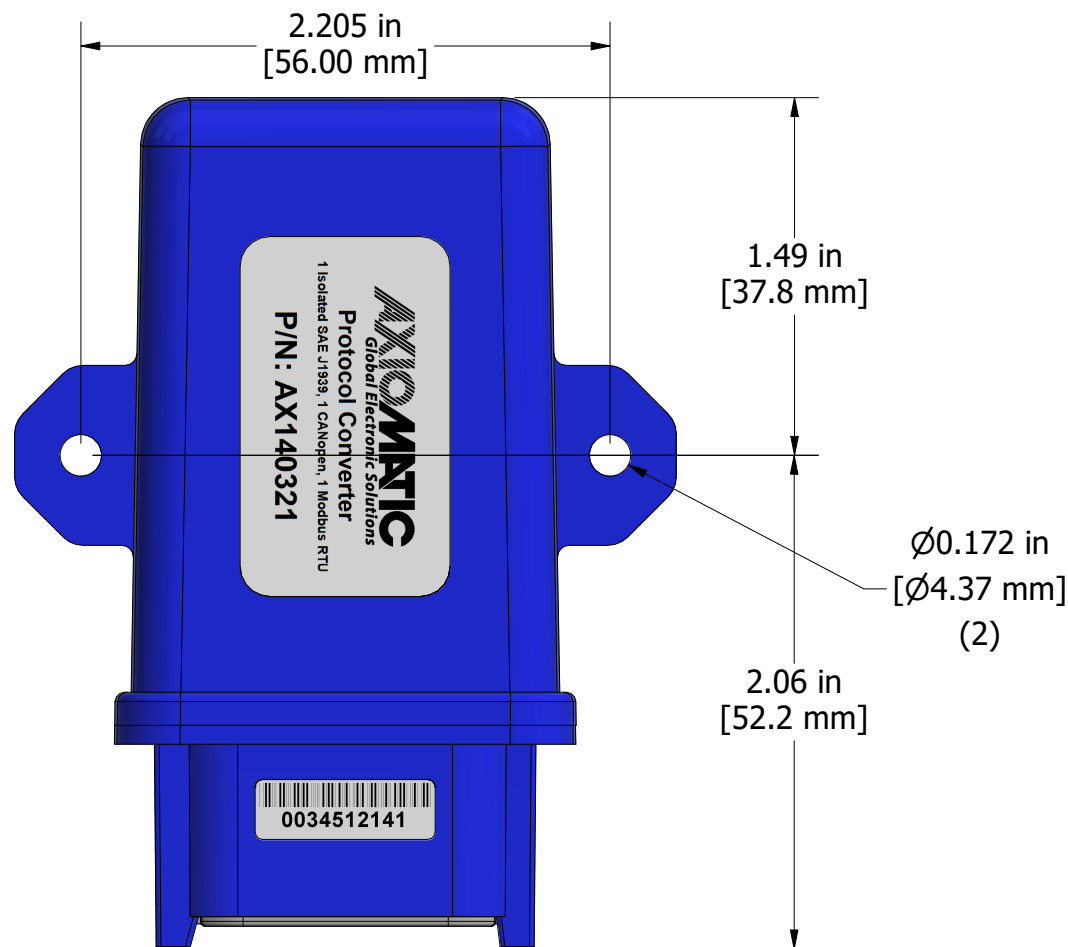

TE Deutsch DTM04-12PA receptacle mates with TE Deutsch DTM06-12SA

| DIMENSIONS ARE IN inches [mm] | | |
|---|--------------------|-----------------------------------|
| Unless otherwise noted, tolerances as stated. | | |
| TOLERANCES | FABRICATION | MACHINING/CASTING/ MOLDING |
| X.XXX" [X.XX mm] | ± 0.015" [0.38 mm] | ± 0.005" [0.13 mm] |
| X.XX" [X.X mm] | ± 0.03" [0.7 mm] | ± 0.008" [0.2 mm] |
| X.X" [X mm] | ± 0.06" [1.5 mm] | ± 0.03" [0.7 mm] |
| | ANGLES ± 1.0 | ANGLES ± 0.5 |
| | | others ISO 2768-2 class K |

| | | | | | | | |
|---|-------------------------------|--------------------|---|-----------------------|---------------------|--|--|
| <small>PROPRIETARY</small> THE INFORMATION CONTAINED IN THIS DRAWING IS CONFIDENTIAL AND PROPRIETARY AND REMAINS THE EXCLUSIVE PROPERTY OF AXIOMATIC TECHNOLOGIES CORPORATION. THIS DRAWING MAY NOT BE USED, REPRODUCED IN WHOLE OR IN PART, NOR REVEALED TO OTHERS WITHOUT THE PRIOR WRITTEN CONSENT OF AXIOMATIC TECHNOLOGIES CORPORATION. BY ACCEPTANCE OF THIS DRAWING, THE BEARER AGREES TO THESE CONDITIONS. | | | | | | <small>AXIOMATIC TECHNOLOGIES CORPORATION</small> 5915 WALLACE ST. MISSISSAUGA, ON CANADA L4Z 1Z8 905-602-9270 | |
| MATERIAL NA | DRAWN TF | DATE 2021-08-11 | TITLE CAN-Modbus RTU Converter, 1 Isolated SAE J1939, 1 Isolated CANopen, 1 Modbus RTU | | | | |
| FINISH NA | CHECKED AW | DATE 2024-09-17 | DWG REV D1 | DWG NO AX140321-MD | PART REV A | | |
| THIRD ANGLE PROJECTION | TOOL INVENTOR SIZE B | APPROVED GDV | DATE 2024-09-17 | SCALE 1.5 | PART NO AX140321 | SHEET 1 of 1 | |

4

3

2

1