

REVISION HISTORY			
REV	DESCRIPTION	DATE	APPROVED
P2-D1	PRODUCTION PILOT	2024-05-17	GDV

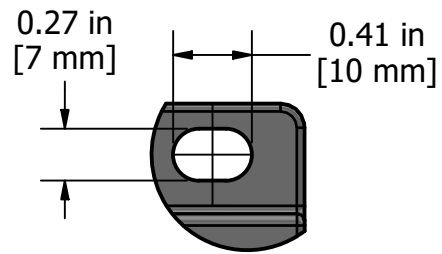

**Detail C**  
Mounting Slots  
To Suit M6 Or 1/4" Bolts

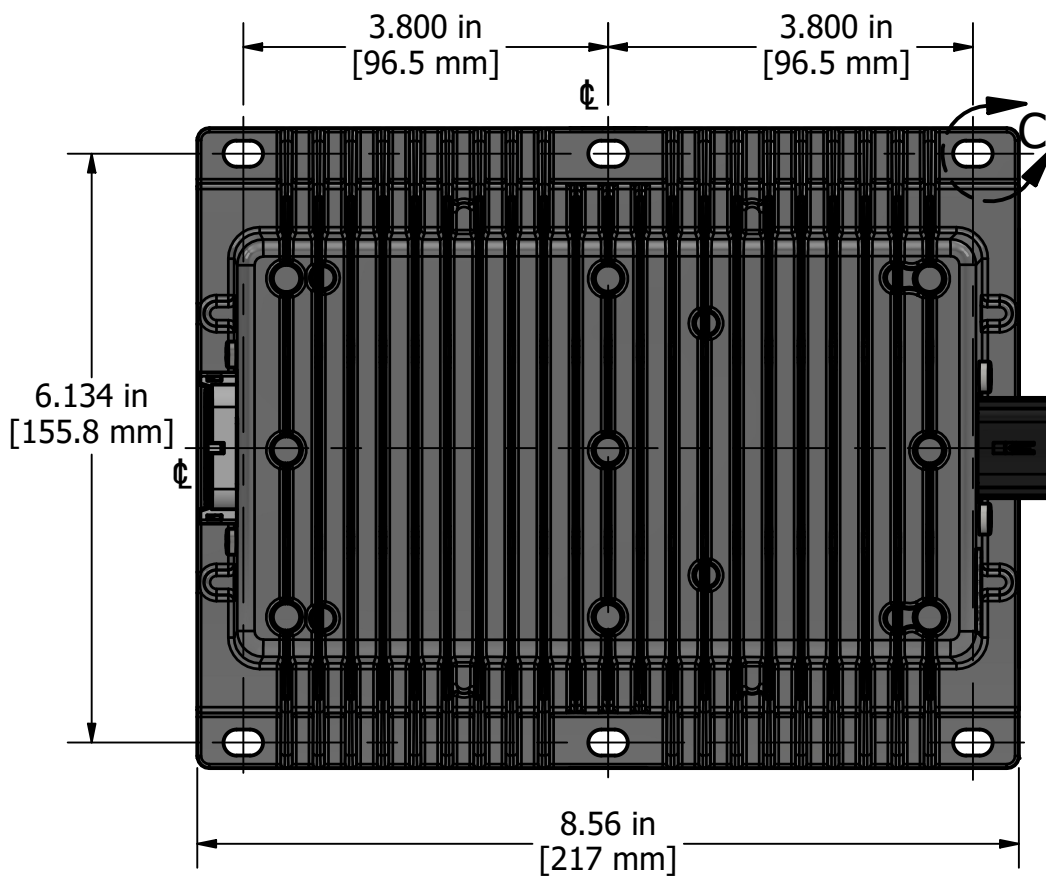

Unit Label

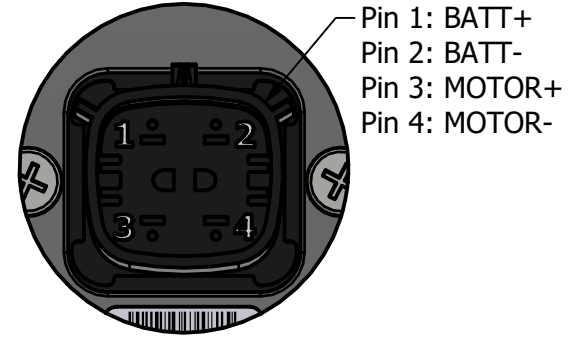

**Detail A**  
Molex 19436-0411  
4-Pin Connector  
Mates with  
Molex 194320001

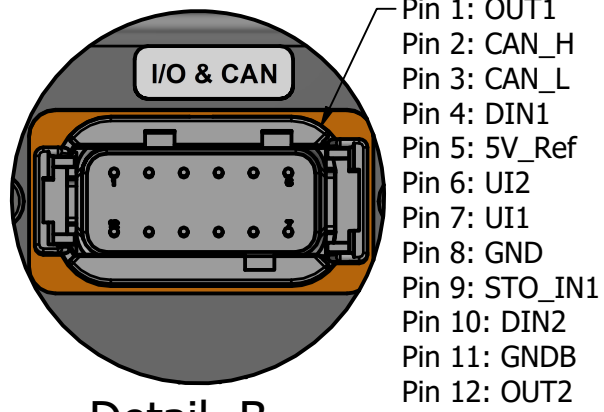

**Detail B**  
Deutsch DTM13-12PA  
12-Pin Connector  
Mates with  
Deutsch DTM06-12SA

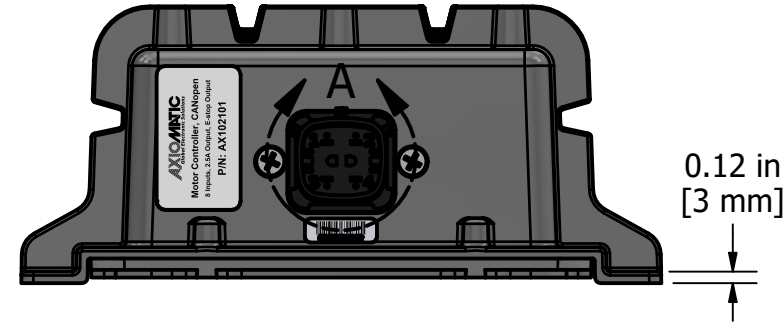
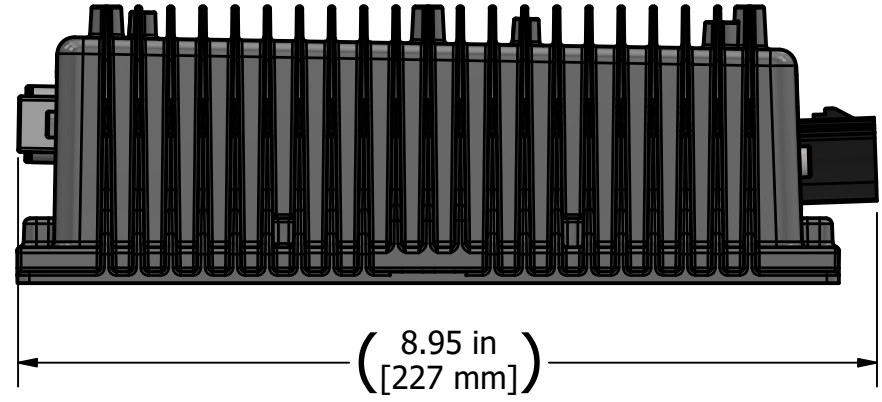
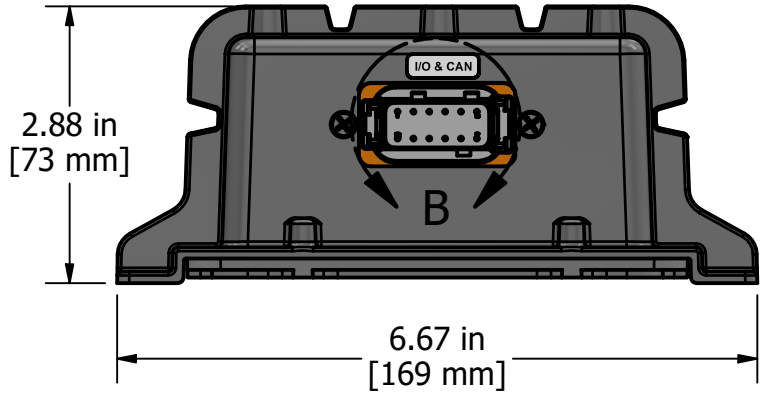

PROPRIETARY  
THE INFORMATION CONTAINED IN THIS DRAWING IS CONFIDENTIAL AND PROPRIETARY AND REMAINS THE EXCLUSIVE PROPERTY OF AXIOMATIC TECHNOLOGIES CORPORATION. THIS DRAWING MAY NOT BE USED, REPRODUCED IN WHOLE OR IN PART, NOR REVEALED TO OTHERS WITHOUT THE PRIOR WRITTEN CONSENT OF AXIOMATIC TECHNOLOGIES CORPORATION. BY ACCEPTANCE OF THIS DRAWING, THE BEARER AGREES TO THESE CONDITIONS.



DIMENSIONS ARE IN INCHES [mm] UNLESS OTHERWISE SPECIFIED IN DRAWING TOLERANCE ON: X.XXX [X.XX] ± 0.008 [0.20] X.XX [X.X] ± 0.02 [0.51] (X.XX [X.X]) ± 0.04 [1.00] ANGLES ± 1.0° Others follow ISO 2768-2, tolerance class K	MATERIAL	DRAWN	DATE	TITLE		
	NA	HS	2024-05-10	40A DC MOTOR CONTROLLER		
	FINISH	CHECKED	DATE	DWG REV	DWG NO	PART REV
	NA	TF	2024-05-17	D1	AX102101-MD	P1
THIRD ANGLE PROJECTION	TOOL	APPROVED	DATE	SCALE	PART NO	SHEET
		GDV	2024-05-17	0.5	FG-AX102101	1 of 1
	INVENTOR	SIZE				
		B				