

REVISION			
REV	DESCRIPTION	DATE	APPROVED
R2-D1	released for prototype	July 17-2014	NM
R3-D1	updates to PCB	March 18-2015	NM
A-D1	released to production ECN15-0070	September 15-2015	NM

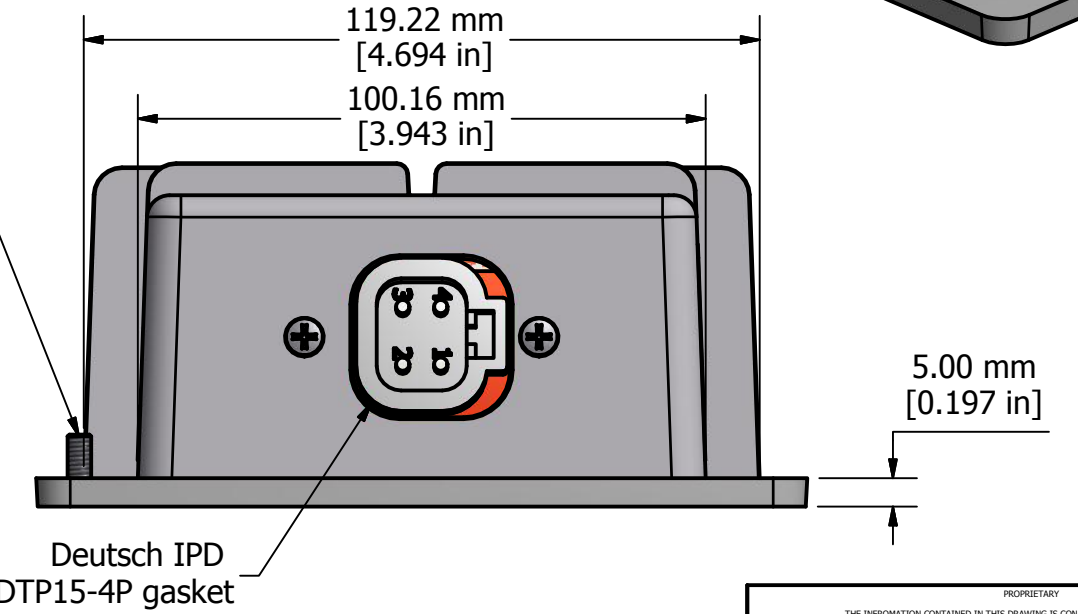
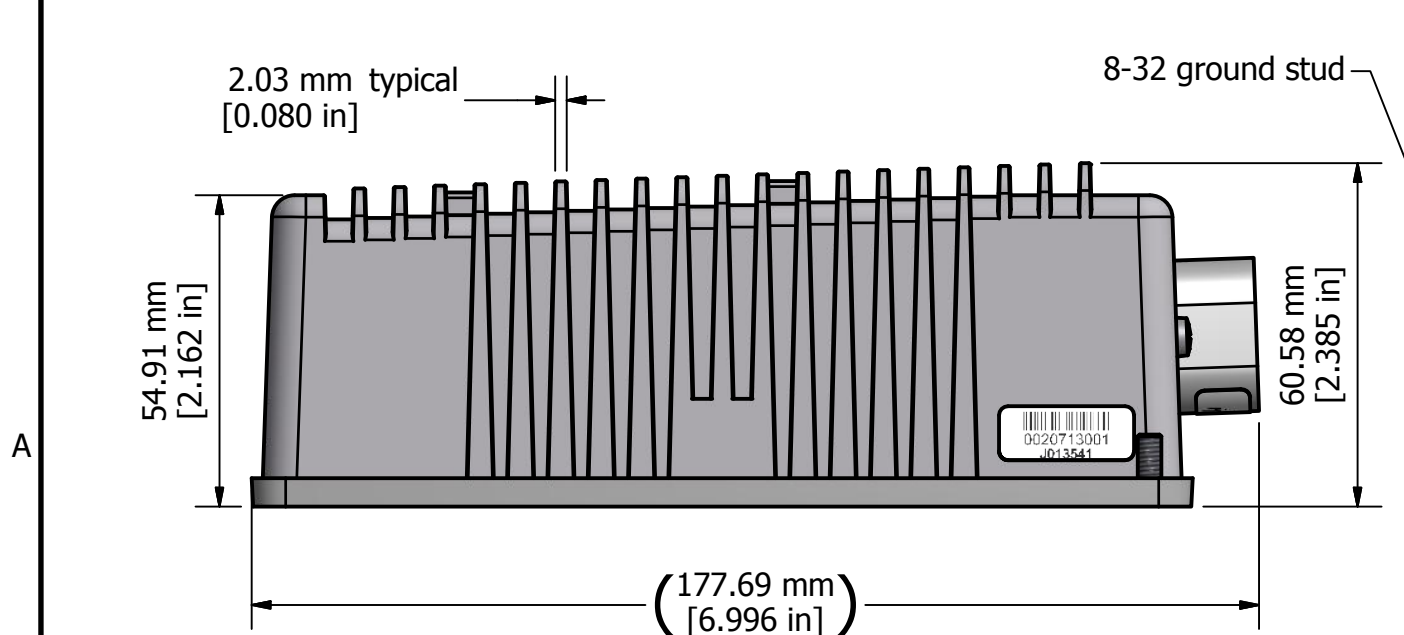
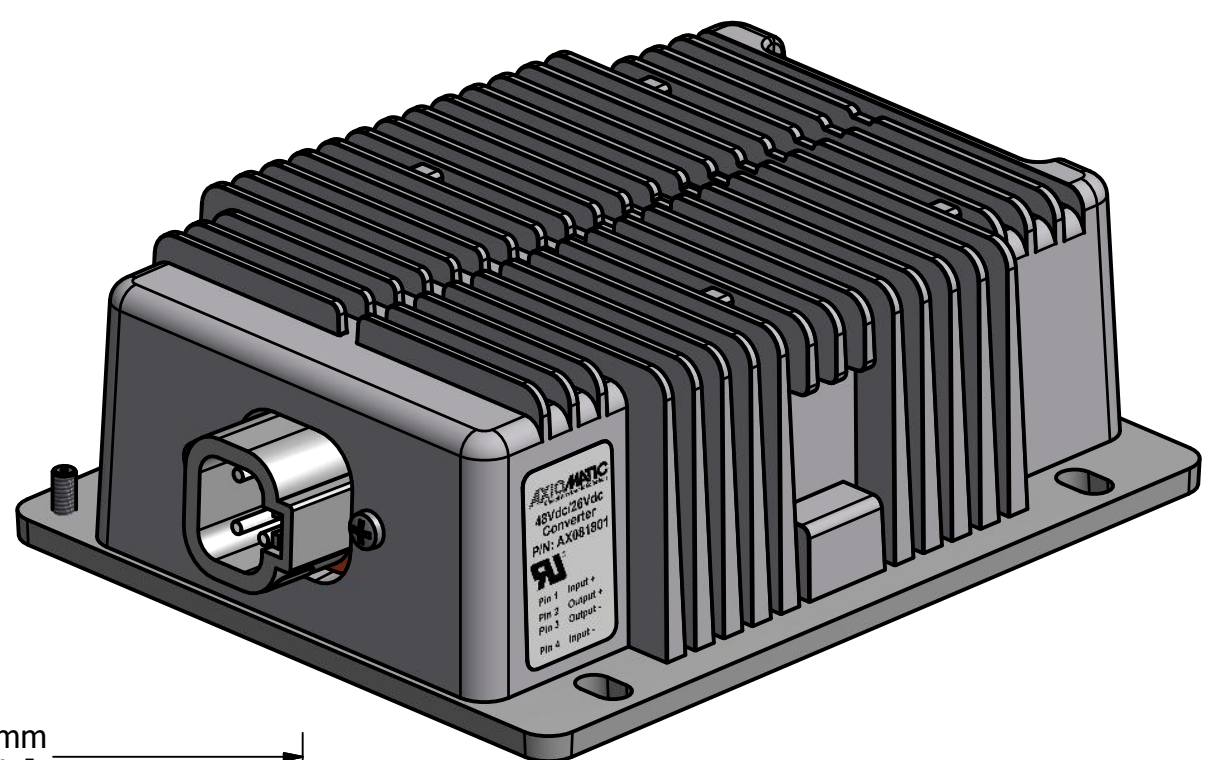

label detail

TOLERANCES		MATERIAL die cast aluminum enclosure	DRAWN TF	DATE 17/07/2014	TITLE 48Vdc - 26Vdc Converter		
fabrication	machining				DWG REV D1	DWG NO AX081801-MD-A	PART REV 2
X.XXX +/- 0.015	X.XXX +/- 0.005		DL	DATE	SCALE full	PART NO AX081801	SHEET 1 of 1
X.XX +/- 0.031	X.XX +/- 0.010						
X.X +/- 0.031	X.X +/- 0.015						
fractional +/- 0.031	fractional +/- 0.031						

PROPRIETARY
THE INFORMATION CONTAINED IN THIS DRAWING IS CONFIDENTIAL AND PROPRIETARY AND REMAINS THE EXCLUSIVE PROPERTY OF AXIOMATIC TECHNOLOGIES CORPORATION. THIS DRAWING MAY NOT BE USED, REPRODUCED IN WHOLE OR IN PART, NOR REVEALED TO OTHERS WITHOUT THE PRIOR WRITTEN CONSENT OF AXIOMATIC TECHNOLOGIES CORPORATION. BY ACCEPTANCE OF THIS DRAWING, THE BEARER AGREES TO THESE CONDITIONS.

AXIOMATIC
Global Electronic Solutions
CORPORATION
5915 WALLACE ST.
MISSISSAUGA, ON
CANADA L4Z1Z8
905-602-9270