

DETAIL A
DT15-4P connector
mates with DT06-4S

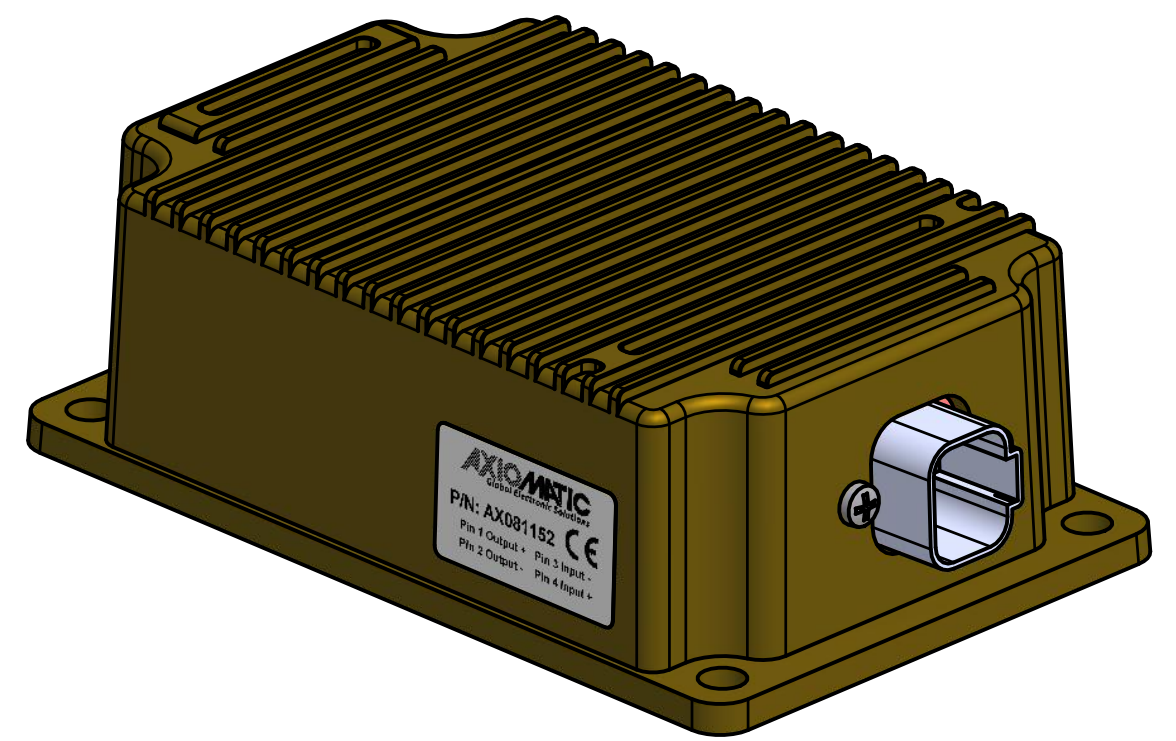

Ø7.06 mm
[0.278 in]
to suit an M6
or 1/4" bolt (4)

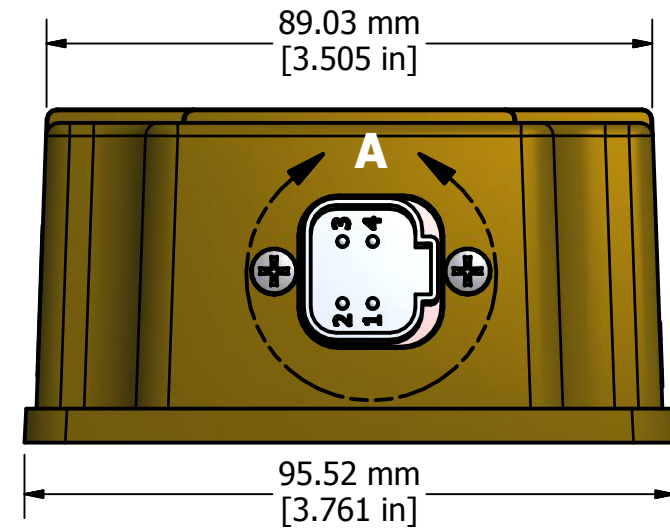
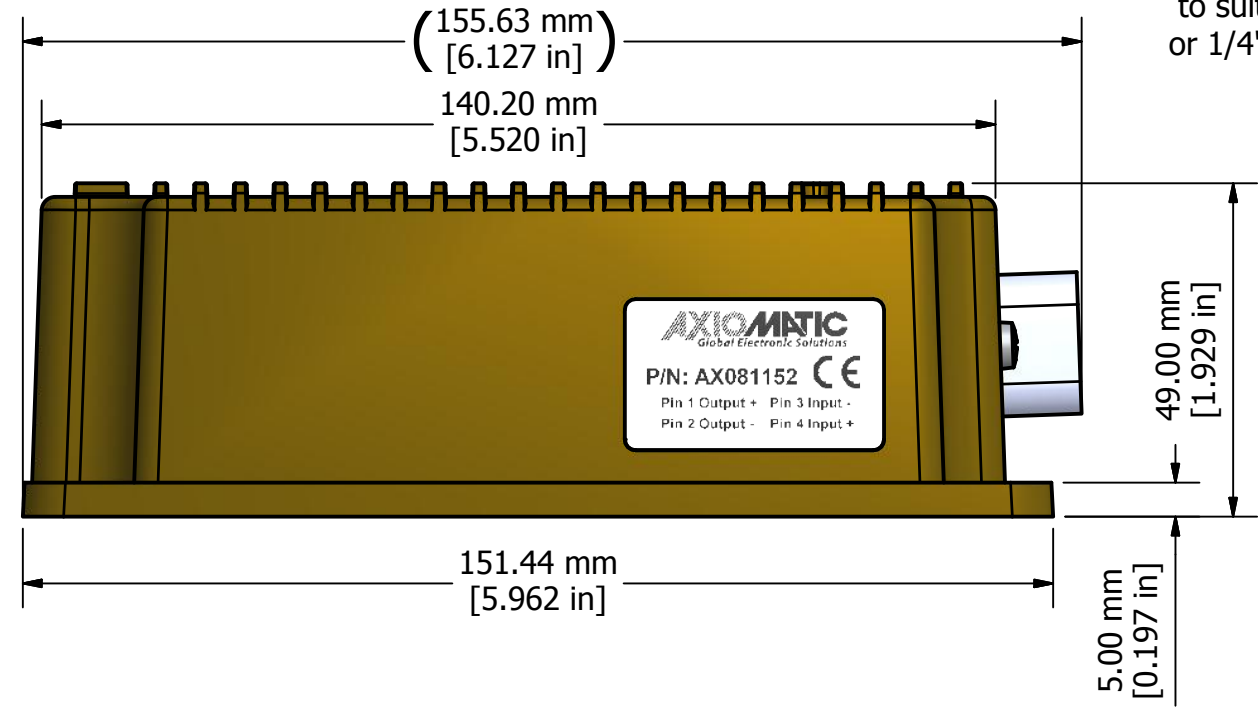

unit label

<small>PROPRIETARY</small> THE INFORMATION CONTAINED IN THIS DRAWING IS CONFIDENTIAL AND PROPRIETARY AND REMAINS THE EXCLUSIVE PROPERTY OF AXIOMATIC TECHNOLOGIES CORPORATION. THIS DRAWING MAY NOT BE USED, REPRODUCED IN WHOLE OR IN PART, NOR REVEALED TO OTHERS WITHOUT THE PRIOR WRITTEN CONSENT OF AXIOMATIC TECHNOLOGIES CORPORATION. BY ACCEPTANCE OF THIS DRAWING, THE BEARER AGREES TO THESE CONDITIONS.		<small>AXIOMATIC TECHNOLOGIES CORPORATION</small> AXIOMATIC Global Electronic Solutions 5915 WALLACE ST. MISSISSAUGA, ON CANADA L4Z1Z8 905-602-9270													
TOLERANCES <table border="1"> <tr> <td>fabrication</td> <td>machining</td> </tr> <tr> <td>X.XXX +/- 0.015</td> <td>X.XXX +/- 0.005</td> </tr> <tr> <td>X.XX +/- 0.031</td> <td>X.XX +/- 0.010</td> </tr> <tr> <td>X.X +/- 0.031</td> <td>X.X +/- 0.015</td> </tr> <tr> <td>fractional +/- 0.031</td> <td>fractional +/- 0.031</td> </tr> </table>		fabrication	machining	X.XXX +/- 0.015	X.XXX +/- 0.005	X.XX +/- 0.031	X.XX +/- 0.010	X.X +/- 0.031	X.X +/- 0.015	fractional +/- 0.031	fractional +/- 0.031	MATERIAL aluminum chassis, EPDM gasket	DRAWN TF	DATE 12/18/2015	TITLE 24VDC-12VDC 5A isolated DC-DC converter
fabrication	machining														
X.XXX +/- 0.015	X.XXX +/- 0.005														
X.XX +/- 0.031	X.XX +/- 0.010														
X.X +/- 0.031	X.X +/- 0.015														
fractional +/- 0.031	fractional +/- 0.031														
FINISH hard anodized		CHECKED	DATE	DWG REV D1	DWG NO AX081152-MD										
		APPROVED	DATE	SCALE full	PART NO AX081152										
				SHEET 1 of 1	PART REV A										