

8-32 ground stud  
0.500 in  
[12.70 mm]

0.125 in  
[3.18 mm]

∅0.281 in THRU  
∨ ∅0.531 in X 90°  
[ ∅7.14 mm THRU  
∨ ∅13.49 mm X 90° ]

6.535 in  
[166.00 mm]  
4.724 in  
[120.00 mm]

4.626 in  
[117.50 mm]  
5.354 in  
[136.00 mm]

Axiomatic DC-DC converter  
(not included)

M6 stainless steel  
hex locknut  
(not included)

AX070136 stainless  
steel mounting plate  
with ground stud

M6 x 16 mm long flat  
head machine screw,  
stainless steel  
(not included)

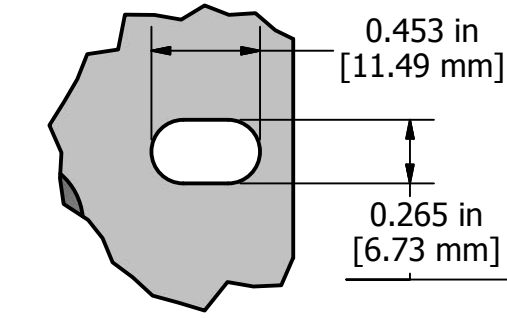

**DETAIL A**  
**mounting slots**

TOLERANCES			
fabrication	+/- 0.015	machining	+/- 0.005
X.XXX	+/- 0.031	X.XXX	+/- 0.010
X.XX	+/- 0.031	X.XX	+/- 0.015
X.X	+/- 0.031	X.X	+/- 0.031
fractional	+/- 0.031	fractional	+/- 0.031

<small>PROPRIETARY</small> THE INFORMATION CONTAINED IN THIS DRAWING IS CONFIDENTIAL AND PROPRIETARY AND REMAINS THE EXCLUSIVE PROPERTY OF AXIOMATIC TECHNOLOGIES CORPORATION. THIS DRAWING MAY NOT BE USED, REPRODUCED IN WHOLE OR IN PART, NOR REVEALED TO OTHERS WITHOUT THE PRIOR WRITTEN CONSENT OF AXIOMATIC TECHNOLOGIES CORPORATION. BY ACCEPTANCE OF THIS DRAWING, THE BEARER AGREES TO THESE CONDITIONS.		<b>AXIOMATIC</b> Global Electronic Solutions <small>AXIOMATIC TECHNOLOGIES CORPORATION          5915 WALLACE ST.          MISSISSAUGA, ON          CANADA L4Z1Z8          905-602-9270</small>	
MATERIAL	DRAWN	DATE	TITLE
hard anodized aluminum die casting, stainless steel adapter plate	TF	10/18/2016	DC converter adapter plate
	CHECKED	DATE	DWG REV
			D1
	APPROVED	DATE	DWG NO
			AX070136-MD
			PART NO
			AX070136
			SHEET
			1 of 1