

unit label

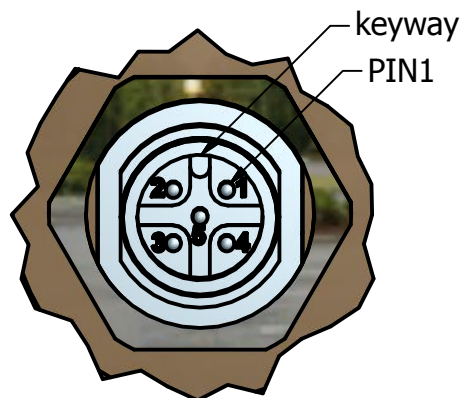

DETAIL B
5 pin A coded M12
male input connector

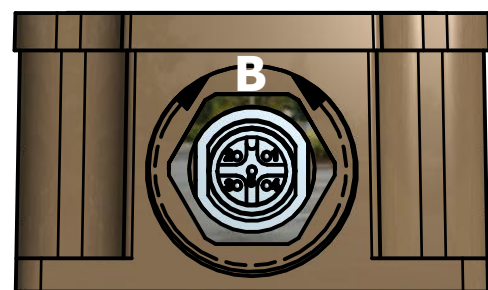
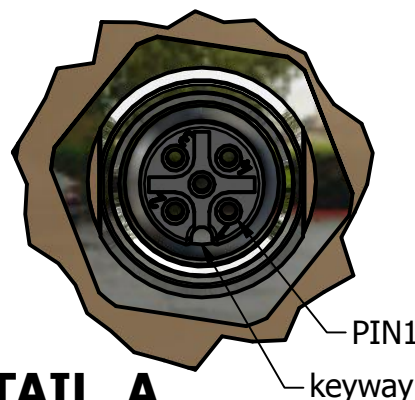
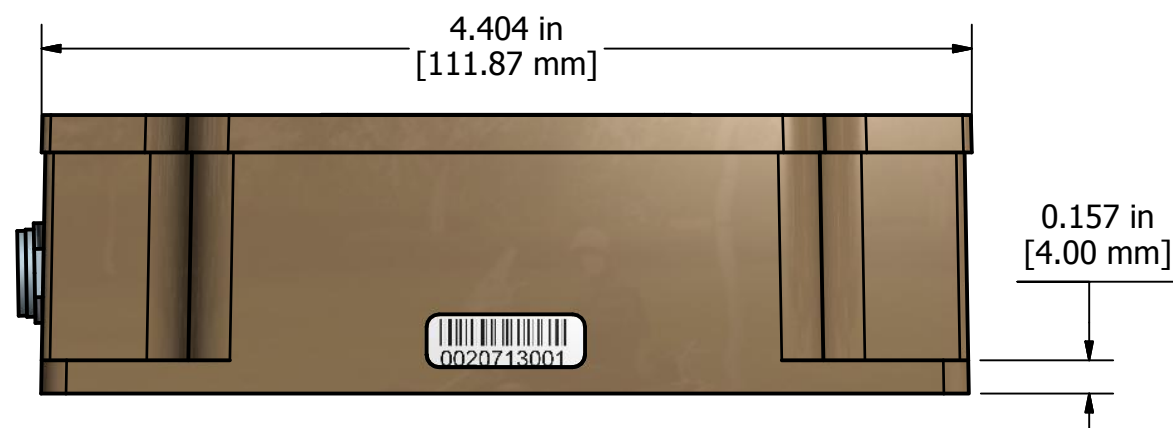

DETAIL A
5 position A coded M12
female output connector

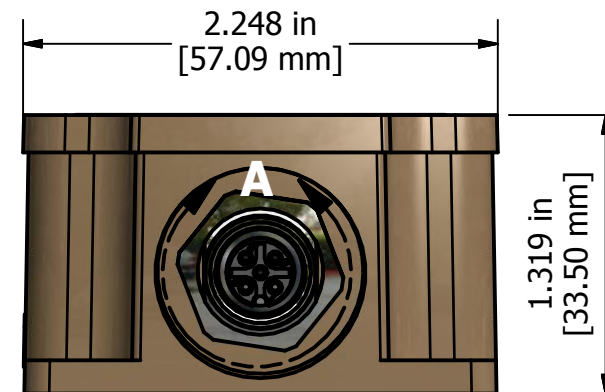

TOLERANCES			
fabrication	machining		
X.XXX +/- 0.015	X.XXX +/- 0.005		
X.XX +/- 0.031	X.XX +/- 0.010		
X.X +/- 0.031	X.X +/- 0.015		
fractional +/- 0.031	fractional +/- 0.031		

<small>PROPRIETARY</small> THE INFORMATION CONTAINED IN THIS DRAWING IS CONFIDENTIAL AND PROPRIETARY AND REMAINS THE EXCLUSIVE PROPERTY OF AXIOMATIC TECHNOLOGIES CORPORATION. THIS DRAWING MAY NOT BE USED, REPRODUCED IN WHOLE OR IN PART, NOR REVEALED TO OTHERS WITHOUT THE PRIOR WRITTEN CONSENT OF AXIOMATIC TECHNOLOGIES CORPORATION. BY ACCEPTANCE OF THIS DRAWING, THE BEARER AGREES TO THESE CONDITIONS.		AXIOMATIC Global Electronic Solutions <small>AXIOMATIC TECHNOLOGIES CORPORATION 5915 WALLACE ST. MISSISSAUGA, ON CANADA L4Z1Z8 905-602-9270</small>	
MATERIAL	DRAWN	DATE	TITLE
hard anodized aluminum housing, EPDM gasket	TF	11/20/2017	High Precision Triaxial Inclinometer, J1939
	CHECKED	DATE	DWG REV
			D1
	APPROVED	DATE	DWG NO
			AX060830-MD
			PART NO
			AX060830
			PART REV
			A
			SCALE
			full
			PART NO
			AX060830
			SHEET
			1 of 1