

4 3 2 1

B

A

B

A

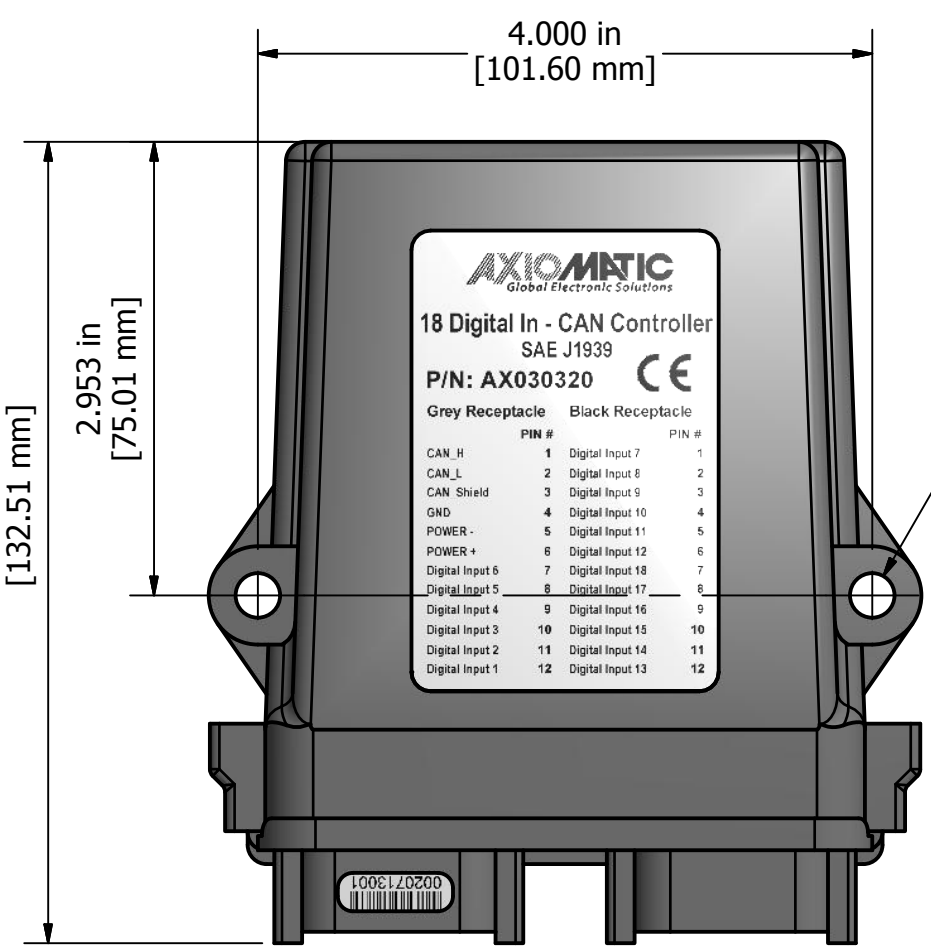

Ø0.290 in [7.37 mm] to suit an M6 or 1/4" bolt (2)

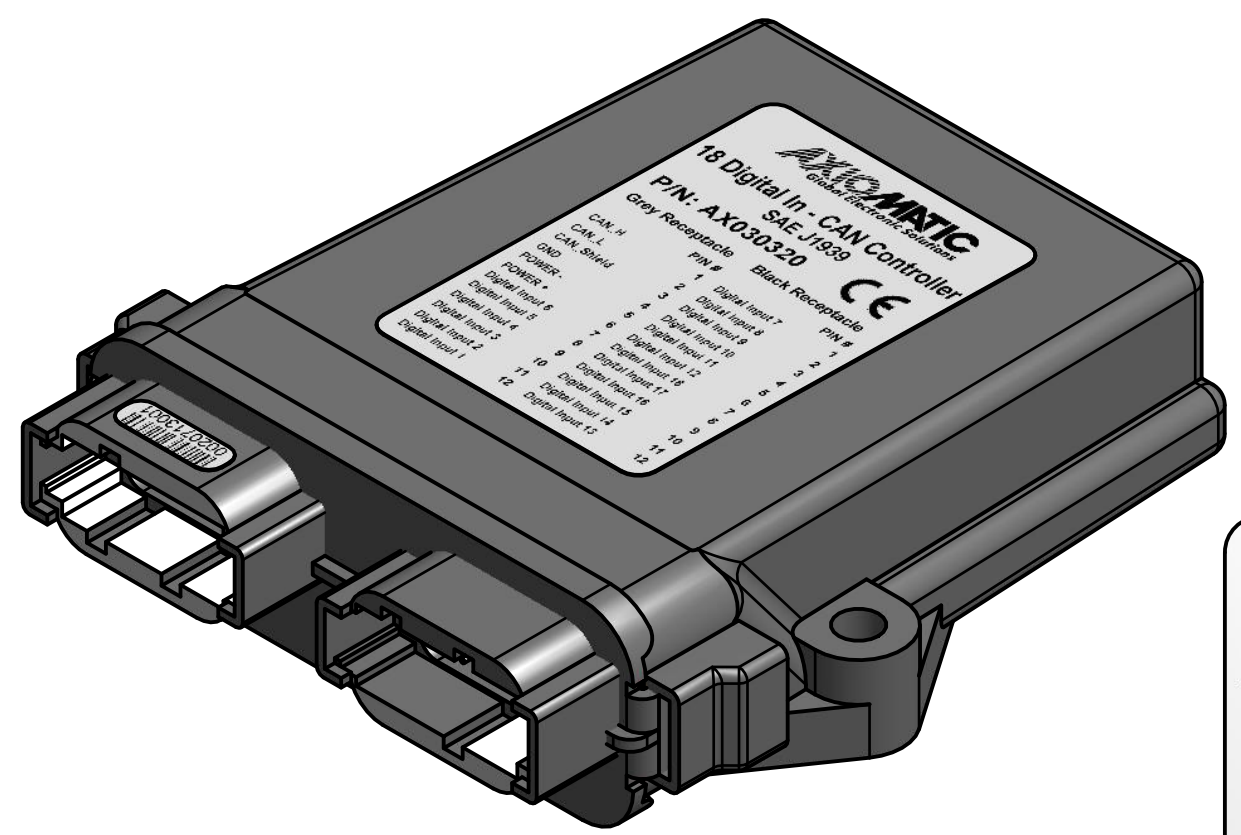

**AXIOMATIC**  
Global Electronic Solutions

**18 Digital In - CAN Controller**  
SAE J1939  
P/N: AX030320

Grey Receptacle		Black Receptacle	
PIN #		PIN #	
1	Digital Input 7	1	
2	Digital Input 8	2	
3	Digital Input 9	3	
4	Digital Input 10	4	
5	Digital Input 11	5	
6	Digital Input 12	6	
7	Digital Input 18	7	
8	Digital Input 17	8	
9	Digital Input 16	9	
10	Digital Input 15	10	
11	Digital Input 14	11	
12	Digital Input 13	12	

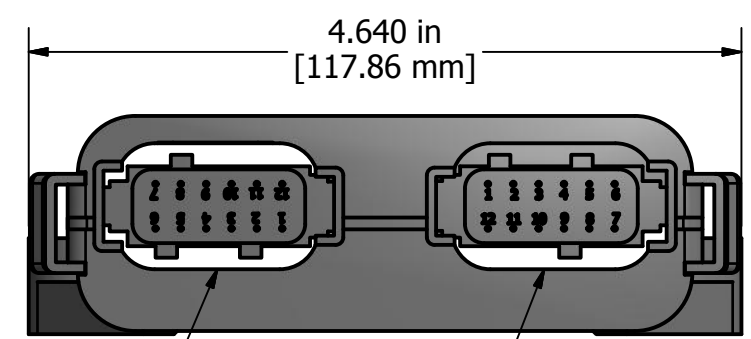

Deutsch IPD DTM13-12PA mates with DTM06-12SA

Deutsch IPD DTM13-12PB mates with DTM06-12SB

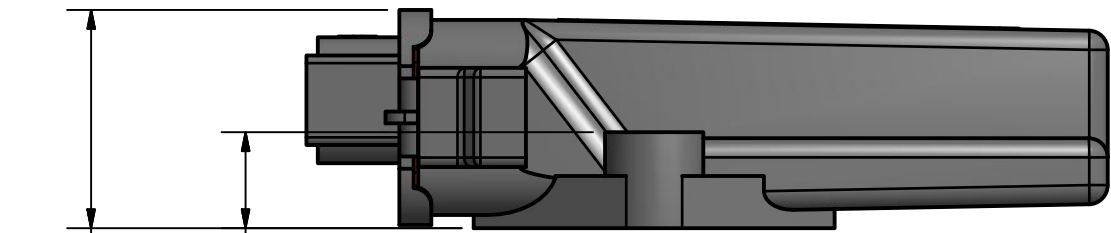

**unit label detail**

<small>PROPRIETARY</small> THE INFORMATION CONTAINED IN THIS DRAWING IS CONFIDENTIAL AND PROPRIETARY AND REMAINS THE EXCLUSIVE PROPERTY OF AXIOMATIC TECHNOLOGIES CORPORATION. THIS DRAWING MAY NOT BE USED, REPRODUCED IN WHOLE OR IN PART, NOR REVEALED TO OTHERS WITHOUT THE PRIOR WRITTEN CONSENT OF AXIOMATIC TECHNOLOGIES CORPORATION. BY ACCEPTANCE OF THIS DRAWING, THE BEARER AGREES TO THESE CONDITIONS.		<small>AXIOMATIC TECHNOLOGIES CORPORATION</small> <b>AXIOMATIC</b> Global Electronic Solutions 5915 WALLACE ST. MISSISSAUGA, ON CANADA L4Z1Z8 905-602-9270																							
<b>TOLERANCES</b> <table border="1"> <tr> <th colspan="2">fabrication</th> <th colspan="2">machining</th> </tr> <tr> <td>X.XXX</td><td>+/- 0.015</td> <td>X.XXX</td><td>+/- 0.005</td> </tr> <tr> <td>X.XX</td><td>+/- 0.031</td> <td>X.XX</td><td>+/- 0.010</td> </tr> <tr> <td>X.X</td><td>+/- 0.031</td> <td>X.X</td><td>+/- 0.015</td> </tr> <tr> <td>fractional</td><td>+/- 0.031</td> <td>fractional</td><td>+/- 0.031</td> </tr> </table>		fabrication		machining		X.XXX	+/- 0.015	X.XXX	+/- 0.005	X.XX	+/- 0.031	X.XX	+/- 0.010	X.X	+/- 0.031	X.X	+/- 0.015	fractional	+/- 0.031	fractional	+/- 0.031	MATERIAL <b>PA66 glass fill housing with a silicone gasket</b>	DRAWN <b>TF</b>	DATE <b>9/14/2018</b>	TITLE <b>18 Digital Signal Inputs, CAN Controller, SAE J1939, 54 CAN Transmit Messages</b>
fabrication		machining																							
X.XXX	+/- 0.015	X.XXX	+/- 0.005																						
X.XX	+/- 0.031	X.XX	+/- 0.010																						
X.X	+/- 0.031	X.X	+/- 0.015																						
fractional	+/- 0.031	fractional	+/- 0.031																						
CHECKED 	DATE 	DWG REV <b>D1</b>	DWG NO <b>AX030320-MD</b>	PART REV <b>A</b>																					
APPROVED 	DATE 	SCALE <b>full</b>	PART NO <b>AX030320</b>	SHEET <b>1 of 1</b>																					

A

A

4 3 2 1